

# SHORT WAVE AND TELEVISION

WORLD'S LARGEST SHORT WAVE CIRCULATION

MARCH

See Page 594



25¢  
IN U.S. AND  
CANADA

HUGO GERNSBACK, Editor

# The Radio Experimenter's Magazine

# SEE this remarkable book at your dealer

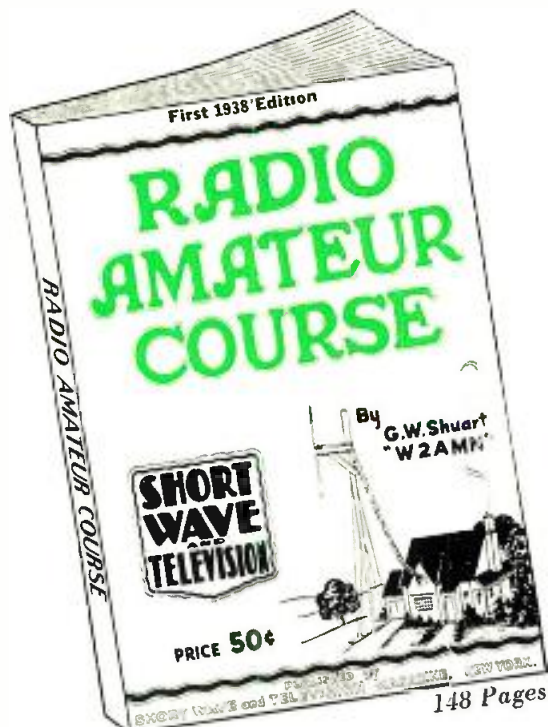

Glance over its 148 pages containing over 150 diagrams and halftone cuts. Read *step by step* how you can obtain the foundation of a *short wave radio education*

**This book represents the biggest value you ever received for 50c**

Written by Geo. W. Shuart, W2AMN—  
the authority on short waves

A new book that will appeal to tens of thousands—  
An essential book for all beginners—

Your library is not complete without it

## ON SALE AT THE FOLLOWING DEALERS

- ARIZONA**  
Sam's Cigar Store,  
127 N. First Ave.,  
Phoenix.
- CALIFORNIA**  
Scott Wholesale Radio Co.,  
344 E. Fourth Street,  
Long Beach.  
Offenbark Electric Co., Ltd.,  
1432 Market Street,  
San Francisco.  
Zack Radio Supply Co.,  
1426 Market Street,  
San Francisco.
- COLORADO**  
Auto Equipment Co.,  
11th at Lawrence,  
Denver.
- CONNECTICUT**  
Radio Inspection Service Co.,  
227 Asylum Street,  
Hartford.  
Stern Wholesale Parts, Inc.,  
Stern Bldg., 210 Chapel St.,  
Hartford.
- GEORGIA**  
Wholesale Radio Service Co., Inc.,  
120 W. Peachtree St., N.W.,  
Atlanta.
- ILLINOIS**  
Allied Radio Corporation,  
833 West Jackson Blvd.,  
Chicago.  
Newark Electric Company,  
126 W. Madison Street,  
Chicago.  
Wholesale Radio Service Co., Inc.,  
301 W. Jackson Blvd.,  
Chicago.
- INDIANA**  
Van Sickle Radio, Inc.,  
31 West Ohio Street,  
Indianapolis.
- MASSACHUSETTS**  
Greater Boston Distributors,  
10 Valtham St.,  
Boston.  
H. Jappe Co., 46 Cornhill,  
Boston.  
Wholesale Radio Service Co., Inc.,  
110 Federal Street,  
Boston.  
Springfield Radio Co.,  
207 Dwight Street,  
Springfield.  
H. Jappe Co., 37 Mechanic Street,  
Worcester.
- MICHIGAN**  
Hissl Brothers, Inc.,  
3027 Hamilton Ave.,  
Detroit.
- MISSOURI**  
Modern Radio Company,  
409 No. Third Street,  
Hannibal.  
Hurstlein-Applebee Co.,  
1012 11 Meier Street,  
Kansas City.  
Van Sickle Radio Co.,  
1113 Pine Street,  
St. Louis.
- NEBRASKA**  
Radio Accessories Company,  
2 66 Fannam Street,  
Omaha.
- NEW HAMPSHIRE**  
Radio Service Laboratory,  
1187 Elm Street,  
Manchester.
- NEW JERSEY**  
Aero Radio Co.,  
227 Central Avenue,  
Newark.  
Wholesale Radio Service Co., Inc.,  
219 Central Avenue,  
Newark.
- NEW YORK**  
Wholesale Radio Service Co., Inc.,  
542 E. Fordham Rd.,  
Bronx.  
Wholesale Radio Service Co., Inc.,  
90-08 166th Street,  
Jamaica, L. I.  
Rian, The Radio Man, Inc.,  
64 Day Street,  
New York City.  
Eagle Radio Co.,  
84 Cortlandt Street,  
New York City.  
Federated Purchaser, Inc.,  
25-25 Park Place,  
New York City.  
Harrison Radio Co.,  
12 West Broadway,  
New York City.  
Sun Radio Co.,  
227 Fulton Street,  
New York City.  
Terminal Radio Corp.,  
80 Cortlandt Street,  
New York City.  
Thor Radio Corp.,  
67 Cortlandt St.,  
New York City.  
Try-Mo Radio Co., Inc.,  
85 Cortlandt Street,  
New York City.  
Wholesale Radio Service Co., Inc.,  
100 Sixth Avenue,  
New York City.  
Radio Parts & Equipment Co.,  
244 Clinton Avenue No.,  
Rochester.  
M. Schwartz & Son,  
710-712 Broadway,  
Scheneectady.
- OHIO**  
News Exchange,  
31 So. Main Street,  
Akron.

- Canton Radio & Supply Co.,  
1149 Tuscarawas Street, W.,  
Canton.  
United Radio, Inc.,  
1103 Vine Street,  
Cincinnati.  
The Hughes-Peters Electric Corp.,  
158-180 N. Third Street,  
Columbus.  
Standard Radio Parts Co.,  
137 East Second Street,  
Dayton.
- OREGON**  
Portland Radio Supply Co.,  
1300 W. Burnside Street,  
Portland.
- PENNSYLVANIA**  
Radio Distributing Co.,  
1124-26 Market Street,  
Harrisburg.  
M. & H. Sporting Goods Co.,  
512 Market Street,  
Philadelphia.  
Cameradio Co.,  
963 Liberty Ave.,  
Pittsburgh.
- RHODE ISLAND**  
W. H. Edwards Co.,  
32 Broadway,  
Providence, R. I.
- UTAH**  
O'Loughlin's Wholesale Radio Supply,  
315 South Main Street,  
Salt Lake City.  
Radio Supply, Inc.,  
46 Exchange Place,  
Salt Lake City.
- WASHINGTON**  
Spokane Radio Co., Inc.,  
611 First Avenue,  
Spokane.
- WISCONSIN**  
Radio Parts Co., Inc.,  
530 578 W. State Street,  
Milwaukee.
- TEXAS**  
Amarillo Electric Co.,  
111 East 8th Avenue,  
Amarillo.
- AUSTRALIA**  
McGill's Agency,  
183-184 Elizabeth Street,  
Melbourne.
- CANADA**  
The T. Eaton Co., Ltd.,  
Winnipeg,  
Manitoba.  
Canadian Electrical Supply Co., Limited,  
285 Craig Street W.,  
Montreal, Que.  
Metropolitan News Agency,  
1248 Peel Street,  
Montreal, Que.
- CUBA**  
The Diamond News Co.,  
Palacio Asturiano, Por San Jose,  
Habana.
- ENGLAND**  
Gorrings American News Agency,  
9a. Green Street, Lefcester Square,  
London, W.C.2.
- INDIA**  
Empire Book Mart,  
Box 631,  
Bombay.
- MEXICO**  
American Book Store, S. A.,  
Avenida Matiero 25,  
Mexico City.  
Central De Publicaciones,  
Avenida Juarez, J. Apartado 2430,  
Mexico, D. F.
- NEW ZEALAND**  
Te Aru Book Depot, Ltd.,  
64 Courtenay Place,  
Wellington.
- SOUTH AFRICA**  
Technical Book Co.,  
147 Lombard Street,  
Cape Town.

IF NOT AT YOUR DEALER'S, PLEASE SEND HIS NAME AND ADDRESS AND WE WILL CREDIT HIM WITH YOUR ORDER. PLEASE FILL OUT COUPON BELOW.

SHORT WAVE & TELEVISION, SW-3-38  
99 Hudson Street, New York City.

Gentlemen: I enclose herewith my remittance for 50c. for which please send me my copy of the "RADIO AMATEUR COURSE" postpaid.

Name .....

Address .....

City ..... State .....

Dealer's Name and Address.....

(Send remittance in form of check or money order. If letter contains cash or unused U. S. postage stamps, register it.)

Be sure to see future copies of *Short Wave & Television* for additional names of dealers handling this book.  
**SHORT WAVE & TELEVISION,** 99 HUDSON ST.,  
NEW YORK CITY

# Men Now in Radio who don't think they know it all READ THIS

## HOW TO MAKE MORE MONEY -- WIN PROMOTIONS

Are YOU making all the money you should in Radio? Read these letters from men who were in Radio before they took my Training. Charles F. Helmuth, 419 N. Mass Ave., Atlantic City, N. J. writes: "I started Radio in the U.S. Marines in 1917. Later I took the N.R.I. Course. Now I am my own boss, and get jobs over others who were sure they had them. I owe plenty to N.R.I. Training."

Another graduate, Robert W. Meyers, 437 1/2 Walnut Street, Coshocton, Ohio, writes: "I had played at Radio and became interested in making it my life's work. While taking your Course I did spare time Radio service work, and after graduating, devoted my entire time to Radio Servicing. I gained many new customers due to the fact that I had Specialized Training."

### Recognized Ability Brings Higher Earnings

Ordinary hit-or-miss methods simply will not solve the intricate problems the service man meets today. Modern all-wave, multi-tube, multi-circuit, push-button Radio sets present servicing problems which require specialized training. New high fidelity equipment, A.V.C. and A.F.C. circuits, new high-frequency I.F. Channels, new type tubes, new and more complicated "midsets" and large console receivers present many problems which can only be solved by the man with a sound working knowledge of fundamental Radio principles, plus a modern servicing technique. The well-trained servicing Experts are getting the service work today--while the "hit-or-miss," "hunt-poke-and-hope" servicemen are the ones who are crying because their business is going to somebody else.

### Get Ready For Television

We give you not only the training in fundamental principles which you need to make more money in Radio now--but get you ready for Television, as well. Our Course includes information on all types of Television equipment, scanning discs, mirror scanners, modern cathode ray Television tubes, Television sweep circuits, amplifiers, frequency requirements, mechanical and electronic scanning devices, synchronizing, framing, Television antennas, and many other facts you must know to be able to service Television receivers and other Television apparatus. Be the man in your city who is READY to meet the demand for service, sales and installation when Television arrives.

### Prepare for Opportunities in All Fields of Radio

We train you not only to be a recognized Expert servicing all modern receivers, but give you the knowledge of fundamental principles you need for success in any field of Radio. You learn Public Address Work, a newer and profitable field of Radio--to install and service inter-office communication systems, a new and rapidly growing field--for Commercial and Broadcast Station operation--to install and maintain many types of Electronic Devices and Controls such as Burglar Alarms, Automatic Counting Machines, etc., etc.

Norman R. Hood, 1321 Burkharrell Ave., Akron, Ohio, writes: "I did not start your course as a beginner. Radio was my hobby from 1911 to 1920. After seven years as a commercial operator, I saw the need for specialized training. Since graduating I have operated various types of Radio installations and designed and constructed broadcast studios, commercial short wave telegraph stations, engaged in police Radio work and am now with the P. O., in their engineering laboratory." Our Training opens MANY opportunities for you--not just a few. Men we trained are making good money in all branches of Radio today.

### Mail Coupon for Free Sample Lesson and Complete Information

Get this lesson "Broadcast All-Wave and Television Superheterodyne Principles" free of any obligation. Read it, examine it, see for yourself how we train you, why our methods have helped others. Then decide for yourself whether you feel we can benefit you. H. P. Pletsch, 182 Bolling Springs Ave., East Rutherford, N. J., writes: "Before taking your Course, I had many years of experience, but found I did not understand as much of the true fundamentals of Radio as I thought. I have benefited by taking your Course."

James Balsanello, 117 N. Robertson Blvd., Los Angeles, Calif., writes: "Before I enrolled for your course I was an ordinary Radio serviceman. I am now in charge of the service department for E. H. Scott Radio Labs. Inc. here and I owe my real understanding of Radio to your Course. Find out how much our Training will help you make more money. MAIL THE COUPON BELOW TODAY in an envelope, or Paste it on a penny postcard."

J. E. SMITH, President  
National Radio Institute  
Dept. 8CB3A  
Washington, D. C.



# If You're Not Working in Radio Now--Read This

## YOU CAN TRAIN AT HOME TO GET INTO RADIO AT GOOD PAY

Do you want to make more money? Do you want to cash in on your present interest in Radio? I'm sure I can train you at home in your spare time for a good Radio Job--positive that I can show you how to get and hold a good Radio Job or start a spare time or full time business of your own. Let me send you a Sample Lesson absolutely free. Examine it, read it, see how easy it is to understand even if you've never had any Radio experience or training.

### Many Radio Experts Make \$30, \$50, \$75 a Week

Radio broadcasting stations employ engineers, operators, station managers and pay up to \$5,000 a year. Spare time Radio set servicing pays as much as \$200 to \$500 a year--full time jobs with Radio jobbers, manufacturers, dealers as much as \$30, \$50, \$75 a week. Many Radio Experts operate their own full time or part time Radio sales and service businesses. Radio manufacturers and jobbers employ testers, inspectors, foremen, engineers, servicemen, paying up to \$6,000 a year. Radio operators on ships get good pay, see the world besides. Automobile, police, aviation, commercial Radio, loud speaker systems are newer fields offering good opportunities now and for the future. Television promises to open many good jobs soon. James E. Ryan, 1535 Slade Street, Fall River, Mass., writes: "I was working in a garage when I enrolled with N.R.I. I am now Radio service manager for the M--- Furniture Co. for their four stores." Men I have trained have good jobs in every branch of Radio.

### Many Make \$5, \$10, \$15 a Week Extra in Spare Time While Learning

Almost every neighborhood needs a good spare time serviceman. The day you enroll I start sending you Extra Money Job Sheets. They show you how to do Radio repair jobs, how to cash in quickly. Throughout your training I send you plans and ideas that have made good spare time money--from \$200 to \$500 a year--for hundreds of fellows. I send you special Radio equipment and show you how to conduct experiments and build circuits which illustrate important Radio principles. My training gives you PRACTICAL EXPERIENCE while learning. "After finishing 15 lessons," writes Alison A. Lomax, 804 Salisbury Ave., Spencer, N. C., "I started repairing Radios in my spare time. I soon had my course paid for, capital built up, and after graduating had made enough to start a Radio business of my own."

### I Give You This Professional Servicing Instrument



Here is the instrument every Radio expert needs and wants--an All-Wave, All-Purpose, Set Servicing Instrument. It contains everything necessary to measure A.C. and D.C. voltages and current; test tubes, resistance, adjust and align any set, old or new. It satisfies your needs for professional servicing after you graduate--can help you make extra money servicing sets while training.

### Get My Lesson and 64-Page Book Free Mail the Coupon Now

Act Today. Mail the coupon now for my Free Lesson and my book "Rich Rewards in Radio." Both are free to any one over 16 years old. My book points out Radio's spare time and full time opportunities and those coming in Television tells about my Training in Radio and Television shows you letters from men I have trained, telling what they are doing and earning. Find out what Radio offers YOU! MAIL THE COUPON in an envelope, or paste it on a penny post card--NOW!

J. E. SMITH, President  
National Radio Institute  
Dept. 8CB3  
Washington, D. C.



## MEN IN RADIO MAIL FOR FREE LESSON

J. E. SMITH, President, Dept. 8CB3A  
National Radio Institute, Washington, D. C.

Send me your Free Lesson and full information about how your Training can help men already in Radio improve their positions and earnings. (Please write plainly).

Name ..... Age .....

Address .....

City ..... State .....

23PR-2

## MEN NOT IN RADIO MAIL FOR FREE BOOK

J. E. SMITH, President, Dept. 8CB3  
National Radio Institute, Washington, D. C.

Dear Mr. Smith: Without obligating me, send the sample lesson and your book which tells about the spare time and full time opportunities in Radio and explains your 50-50 method of training men at home in spare time to become Radio Experts. (Please write plainly).

Name ..... Age .....

Address .....

City ..... State .....

14X-1



The Next issue comes out March 1st

HUGO GERNSBACK, Editor
H. WINFIELD SECOR, Manag. Editor
M. HARVEY GERNSBACK, Assoc. Editor

FEATURE AUTHORS THIS MONTH

- H. M. Hucke
Paul Popenoe
C. W. Palmer
F. L. Sprayberry
W. Schrage
H. G. McEntee, W2FHP

IN THE APRIL ISSUE

- The "S.W.&T." Television Receiver—Part II, with construction details, C. W. Palmer.
DeLuxe 5-Meter Transmitter, Art Gregor.
A New I-Tube Receiver for the S-W Beginner.
High-Efficiency Superhet for the S-W Fan and Ham.
Radio Control for Model Ships, Pierre Delaunay.

OUR COVER

is a photograph of the mobile television station operated by the British Broadcasting Corporation in connection with their television station at Alexandra Palace, London. The principle of operation of this unit is identical to that of the new NBC vans described on page 600 of this issue.

—By Courtesy of B.B.C.

IN THIS ISSUE

NEW DEVELOPMENTS

Table with 2 columns: Article Title and Page Number. Includes 'The Future of Ultra High Frequencies in Air Transportation' and 'Short-Wave Pictorial'.

S-W STATIONS—HOW TO FIND THEM

Table with 2 columns: Article Title and Page Number. Includes 'Let's Listen In with Joe Miller' and 'World S-W Stations'.

TELEVISION

Table with 2 columns: Article Title and Page Number. Includes 'You Can "See" Over This Telephone Line' and 'Cathode-Ray Tube Television Receiver'.

LATEST SHORT WAVE APPARATUS

613

CONSTRUCTOR

Table with 2 columns: Article Title and Page Number. Includes 'New Experiments With Radio Apparatus' and 'Cathode-Ray Tube Television Receiver'.

MISCELLANEOUS

Table with 2 columns: Article Title and Page Number. Includes 'Uncontrolled Oscillations' and 'Relay Made From Ford Coil'.



Certified Circuits

When you see this seal on a set it is a guarantee that it has been tested and certified in our laboratories, as well as privately in different parts of the country. Only constructional—experimental sets are certified. You need not hesitate to spend money on parts because the set and circuit are bona fide. This is the only magazine that renders such a service.

SHORT WAVE & TELEVISION—Published monthly on the first of the month, 12 numbers per year. Entered as second-class matter May 7, 1930, at the post office at Mt. Morris, Ill., under the act of March 3, 1879.

SHORT WAVE & TELEVISION

Copyright 1938, by H. Gernsback
Published by Popular Book Corporation
Publication Office—29 Worthington St., Springfield, Mass. Editorial and Executive Offices—59 Hudson St., New York, N.Y.

# MANY OPPORTUNITIES FOR THE COYNE TRAINED RADIO MAN

*Are You Ready for a Better Job - More Pay?*

Don't be an untrained man. Let me show you how to get your start in Radio — a fast growing, live money-making industry.

Prepare for jobs as Assembler, Inspector and Tester—Radio Sales or Service and Installation Work—Broadcasting Station Operator—Wireless Operator on a Ship or Airplane or Sound Work—HUNDREDS OF OPPORTUNITIES for a real future in radio!

## 2 Weeks of Shop Training

We don't teach by book study. We train you on a great outlay of Radio, Television and Sound equipment—on scores of modern Radio Receivers, actual Broadcasting equipment, Television apparatus and Sound Reproduction equipment, Code and Telegraph equipment, etc. You don't need advanced education or previous experience. We give you—RIGHT HERE IN THE COYNE SHOPS—the actual practice and experience you'll need for your start in this great field. And because we cut out all useless theory and only give that which is necessary you get a practical training in 12 weeks. Mail coupon for all facts about my school and training methods.



## TELEVISION *and* PUBLIC ADDRESS

Television is sure to come as a commercial industry. Rapid progress is now being made in developing this new field. It will offer opportunities to the man who is trained in Radio. Here at Coyne you learn Television principles, and work on actual Television equipment. Public Address Systems offer opportunities to the Trained Radio Man. Here is a great new Radio field which is rapidly expanding. Prepare NOW for these wonderful opportunities! Learn Radio Sound Work at COYNE on actual Sound Reproduction equipment. Not a home study course.

SEND FOR DETAILS OF MY

### "PAY AFTER GRADUATION" PLAN

Mail the Coupon below and I'll tell you about my "Pay After Graduation" Plan which has enabled hundreds of others to get Coyne training with very little money. On this plan you can get your training first, then take 18 months to complete your small monthly tuition payments starting 5 months after you begin training. Not a home study course.

Mail the coupon for all details of this "Tuition Payment Plan."

### PRACTICAL WORK at COYNE in Chicago

ACTUAL, PRACTICAL WORK. You build and service radio sets. You get training on real Broadcasting equipment. You construct Television Receiving Sets and actually transmit your own Television images over our Television equipment. You work on real Sound equipment. You learn Wireless Operating on Actual Code Practice apparatus. We don't waste time on useless theory. We give you the practical training you'll need for your start in Radio—in 12 short weeks. If you desire code, this requires additional time for which there is no extra charge.

**Mail Coupon Today for All the Facts**

H. C. LEWIS, Pres. RADIO DIVISION Founded 1899

**Coyne Electrical School**  
500 S. Paulina St., Dept. 38-2K, Chicago, Ill.

### ELECTRIC REFRIGERATION AIR CONDITIONING AUTOMOBILE ELECTRICAL WORK

Instruction now included at no extra cost. Here is your opportunity to learn these valuable allied lines without extra tuition charge.

### PART TIME EMPLOYMENT TO HELP YOU "EARN WHILE LEARNING"

If you are short of money and need part time employment to help pay for your room and board while training, my Employment Department will help you get a part time job.



### GET THE FACTS

Don't let lack of money prevent your sending in the Coupon. Mail the Coupon today and I Will send you the Big FREE Coyne Book full of FACTS.

H. C. LEWIS, Pres.

**Radio Division, Coyne Electrical School**  
500 S. Paulina St., Dept. 38-2K, Chicago, Ill.

Dear Mr. Lewis:—Send me your Big Free Radio Book, and all details of your "Pay After Graduation" Plan including valuable instruction in Electric Refrigeration, Air Conditioning and Automobile Electrical Work.

Name.....

Address.....

City.....State.....

Please mention SHORT WAVE & TELEVISION when writing advertisers

# ..... THESE OUTSTANDING SHORT WAVE BOOKS ARE Now Available AT YOUR DEALER!

YOU buy parts, tubes, kits, accessories from your local radio dealer—that's what countless thousands of short-wave fans do. Now through a nation-wide distribution service our numerous books are available at your favorite radio dealer—right where you buy other radio equipment. It's more convenient, saves time and you can inspect the books before you buy. Ask your dealer to show you all the books advertised on this page—they're always in stock.

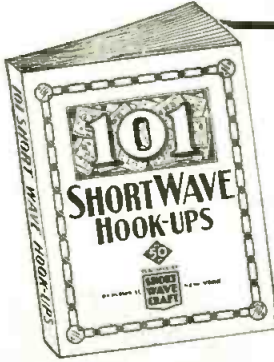

### 101 SHORT WAVE HOOK-UPS

Compiled by the Editors of **SHORT WAVE and TELEVISION**

Here is a worthwhile book that every short wave listener, every short wave fan, and every short wave amateur has wanted for a long time. It gives you the 101 best short wave hook-ups which have appeared heretofore.

100 Illustrations 50c  
72 Pages

### HOW TO BUILD AND OPERATE SHORT WAVE RECEIVERS

This is the best and most up-to-date book on the subject. It is edited and prepared by the editors of **SHORT WAVE and TELEVISION** and contains a wealth of material on the building and operation, not only of typical short wave receivers, but short wave converters as well.

150 Illustrations 50c  
72 Pages



### HOW TO GET BEST SHORT WAVE RECEPTION

M. HARVEY GERNSBACK tells you everything you have ever wanted to know about short wave reception. The author, a professional radio listener and radio fan for many years, gives you his long experience in radio reception and all that goes with it.

40 Illustrations 50c  
72 Pages

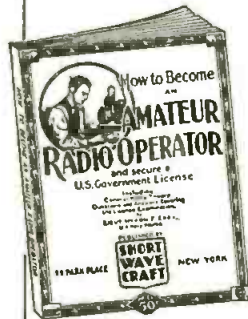
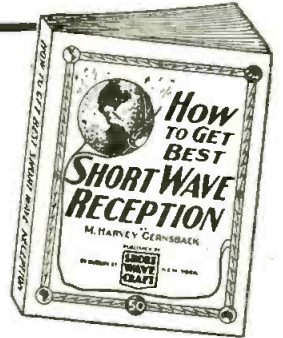

### HOW TO BECOME AN AMATEUR RADIO OPERATOR

By Lieut. Myron F. Eddy, whose experience in the amateur field has made him pre-eminent in this line.

If you intend to become a licensed code operator, if you wish to take up phone work eventually—this is the book you must get.

150 Illustrations 50c  
72 Pages

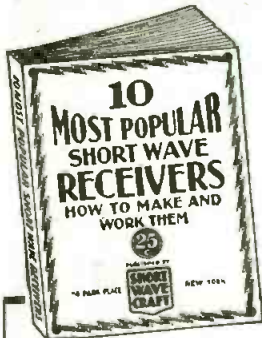

### TEN MOST POPULAR SHORT WAVE RECEIVERS

HOW TO MAKE AND WORK THEM  
The editors of **SHORT WAVE and TELEVISION** have selected ten outstanding short wave receivers and these are described in the new volume. Each receiver is fully illustrated with a complete layout, pictorial representation, photographs of the set complete, hook-up and all worthwhile specifications.

75 Illustrations 25c  
40 Pages

### THE SHORT WAVE BEGINNER'S BOOK

Here is a book that solves four short wave problems—leading you in easy stages from the simplest fundamentals to the present stage of the art as it is known today. It is the only low-priced reference book on short waves for the beginner.

75 Illustrations 25c  
40 Pages

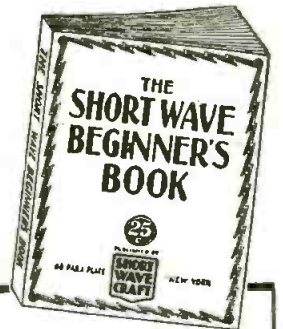

## LOOK FOR YOUR NEAREST DEALER

For convenience the publishers list below dealers in all parts of the world where our books are available. On your next shopping trip be certain to examine these volumes. You're sure to want them for your technical library.

- |  |   |   |   |
|--|---|---|---|
| <p><b>ALABAMA</b><br/>Walther Bros., Montgomery</p> <p><b>ARIZONA</b><br/>Sam's Cigar Store, Phoenix</p> <p><b>CALIFORNIA</b><br/>Electric Supply Co., Oakland<br/>Radio Supply Company, Los Angeles<br/>Radio Television Supply Co., Los Angeles<br/>Pacific Radio Exchange, Inc., Los Angeles<br/>Western Auto Supply, Los Angeles<br/>Zack Radio Supply Co., Los Angeles<br/>Vronnar's Book Store, Pasadena<br/>Western Radio &amp; Elec. Co., San Diego<br/>Offenbach Electric Co., San Francisco<br/>Technical Book Co., San Francisco<br/>Zack Radio Supply Co., San Francisco<br/>Radio Specialties Co., San Jose</p> <p><b>COLORADO</b><br/>Auto Equipment Co., Denver<br/>Interstate Radio Supply, Denver</p> <p><b>CONNECTICUT</b><br/>The Edward P. Judd Co., New Haven</p> <p><b>DELAWARE</b><br/>Wilmington Elec. Spec. Co., Inc., Wilmington</p> <p><b>FLORIDA</b><br/>Radio Accessories Co., Orlando</p> <p><b>GEORGIA</b><br/>Wholesale Radio Service Co., Inc., Atlanta</p> <p><b>ILLINOIS</b><br/>Allied Radio Corporation, Chicago<br/>Walter C. Braun, Inc., Chicago<br/>Chicago Radio Apparatus Co., Chicago<br/>A. C. McClure &amp; Co., Chicago<br/>Midwest Radio Mart, Chicago<br/>Newark Electric Co., Chicago<br/>Sears, Roebuck &amp; Co., Chicago<br/>Max Stein &amp; Co., Chicago<br/>Montgomery Ward &amp; Co., Chicago<br/>Wholesale Radio Service Co., Inc., Chicago</p> | <p><b>INDIANA</b><br/>Van Sickle Radio, Indianapolis</p> <p><b>MASSACHUSETTS</b><br/>DeWolfe &amp; Fitch Co., Boston<br/>The Personal Book Shop, Boston<br/>Wholesale Radio Service Co., Inc., Boston<br/>Library Book House, Springfield<br/>Tremont Elec. Supply Co., Boston</p> <p><b>MICHIGAN</b><br/>Rissi Brothers, Detroit</p> <p><b>MINNESOTA</b><br/>St. Paul Book &amp; Stat. Co., St. Paul</p> <p><b>MISSOURI</b><br/>Burststein-Appelbee Co., Kansas City<br/>Radio Lab., Kansas City<br/>Walter Ashe Radio Co., St. Louis<br/>Van Sickle Radio Co., St. Louis</p> <p><b>NEW JERSEY</b><br/>Radio Apparatus Co., Newark<br/>Wholesale Radio Service Co., Inc., Newark</p> <p><b>NEW YORK</b><br/>Fort Orange Radio Dist. Co., Albany<br/>Wholesale Radio Service Co., Inc., Albany<br/>Wholesale Radio Service Co., Inc., Jamaica, L. I.<br/>American News Co., New York City<br/>Baker &amp; Taylor Co., New York City<br/>Blair, the Radio Man, New York City<br/>David Bogen &amp; Co., New York City<br/>Federated Purchaser, Inc., New York City<br/>Harrison Radio Co., New York City<br/>Radio Circular Co., New York City<br/>G. E. Stechert &amp; Co., New York City<br/>The Steiger Co., New York City<br/>Sun Radio Co., New York City<br/>Thor Radio Corp., New York City<br/>Try-Mo Radio Co., New York City<br/>Van Riemsdyck Book Stores, New York City<br/>Wholesale Radio Service Co., Inc., New York City<br/>H. W. Wilson Co., New York City<br/>Radio Paris &amp; Co., Rochester<br/>M. Schwartz &amp; Son, Schenectady</p> | <p><b>OHIO</b><br/>College Book Exchange, Toledo</p> <p><b>OREGON</b><br/>J. K. Gill Co., Portland</p> <p><b>PENNSYLVANIA</b><br/>Radio Electric Service Co., Philadelphia<br/>Cameradio Co., Pittsburgh</p> <p><b>WASHINGTON</b><br/>Seattle Radio Supply Co., Seattle<br/>Wedel Co., Inc., Seattle<br/>Spokane Radio Co., Spokane</p> <p><b>WISCONSIN</b><br/>Radio Parts Co., Milwaukee</p> <p><b>ARGENTINA</b><br/>Radio Revista, Buenos Aires</p> <p><b>AUSTRALIA</b><br/>McGill's Authorized Agency, Melbourne</p> <p><b>BELGIUM</b><br/>Emil Arens, Brussels</p> <p><b>CANADA</b><br/>T. Eaton &amp; Co., Winnipeg, Man.<br/>Electrical Supplies, Ltd., Winnipeg, Man.<br/>Wholesale Radio Supply, Winnipeg, Man.<br/>Canadian Electrical Supply Co., Ltd., Toronto, Ont.<br/>Radio Trade Supply Co., Ltd., Toronto, Ont.<br/>Canadian Electrical Supply Co., Ltd., Montreal, P. Q.</p> <p><b>BRAZIL</b><br/>Agencia Soave, Sao Paulo</p> <p><b>CHINA</b><br/>China News Co., Shanghai<br/>International Booksellers, Ltd., Shanghai</p> <p><b>CUBA</b><br/>Diamond News Co., Havana</p> <p><b>ENGLAND</b><br/>Goring's Amer. News Agency, London</p> <p><b>FRANCE</b><br/>Toute La Radio, Paris</p> | <p><b>GERMANY</b><br/>Rehr G.M.B.H. SW15, Berlin NW No. 7</p> <p><b>INDIA</b><br/>Empire Book Mart, Bombay</p> <p><b>MEXICO</b><br/>American Book Store, Mexico, D. F.<br/>Central De Publicaciones, S. A., Mexico, D. F.<br/>Jaques Salvo, Mexico, D. F.</p> <p><b>NEW ZEALAND</b><br/>Johns, Ltd., Auckland<br/>James Johnston, Ltd., Dunedin<br/>Te Aro Book Depot, Ltd., Wellington</p> <p><b>SOUTH AFRICA</b><br/>Technical Book Co., Cape Town<br/>Central News Agency, Johannesburg<br/>International House, Johannesburg<br/>South African Radio Publications, Johannesburg</p> |
|--|---|---|---|

IF YOUR DEALER DOES NOT CARRY THESE BOOKS, ORDER DIRECT FROM US. FILL OUT COUPON BELOW. SHIPMENT WILL BE MADE IMMEDIATELY.

**POPULAR BOOK CORPORATION SW-3**  
99 Hudson Street, New York City.

Gentlemen: I enclose herewith my remittance for ..... for which please send me the following books:

.....

.....

Name .....

Address .....

City .....

State .....

(Send remittance in form of check or money order. If letter contains cash or unused U. S. postage stamps, register it.)

**POPULAR BOOK CORPORATION • Publishers • 99 HUDSON STREET • NEW YORK, N. Y.**

Please mention **SHORT WAVE & TELEVISION** when writing advertisers



HUGO GERNSBACK, EDITOR

H. WINFIELD SECOR, MANAGING EDITOR

## The Future of Ultra High Frequencies In Air Transportation

H. M. Hucke

Chief Communications Engineer, United Air Lines

● THE air transport industry, rising from infancy during the past ten years, has been unusually fortunate from a communications standpoint. Its development has paralleled the development of the vacuum tube and, as its needs have grown, the ultra high frequency spectrum has been opened to supply them. Even the style of flying has changed so that the "over the horizon" transmission of the early air mail days is no longer an absolute necessity.

Ten years ago the air lines operated small single-motored planes with a flying procedure aptly termed *hedge hopping*. Because the single motor might not always function perfectly it was deemed wise to keep the earth in sight so that a quick landing could always be made on a handy pasture. Maintaining radio contact with planes under these conditions required frequencies with suitable skip distances to go up and over the neighboring mountain ridges. Radio beacons also required frequencies which would follow the earth's contours so that the plane would not lose them after it had passed below the horizon.

To meet these needs the air lines chose the frequencies near 5.5 mc. by day and 3 mc. by night for their two-way voice channels. The Bureau of Standards chose the frequencies between 200 and 400 kc. for the radio beacons. Both choices were well made and will continue to serve for some years to come.

The coming of reliable multi-motored planes has moved the flight lanes upward. It is no longer necessary to keep the earth in sight and flight at ten to fifteen thousand feet is common practice. Radio waves which skip over the mountains or crawl over the earth's contours are not as essential as they were a few years ago. Tomorrow the planes will move still further upward into the stratosphere and the line-of-sight ultra high frequencies will come into their own.

The immediate advantages of ultra high frequencies on aircraft lie in improved antennas. With the present frequencies antenna efficiencies are poor and only about 20% of our transmitter power is converted into useful radiation. Receiving antennas,

too, will be improved. In addition the use of ultra high frequency antennas will result in improved streamlining.

The radio beacons each of which now require five expensive steel towers will benefit from simpler directive arrays. *Night effect* at present caused by simultaneous reception of both sky wave and ground wave will cease to exist and the *swinging* of beams will disappear. The *multiple course* in mountainous country may even be eliminated though experimentation has not yet established the validity of this assumption.

The position marker is the first of the ultra high frequency facilities to come into commercial aircraft service. Developed by the Bureau of Air Commerce and already in production, it will send a 75 megacycle conical beam upward from the radio beam station at each airport. Planes, flying on the horizontal beam above cloud layers will intercept this vertical beam and know that the landing field lies directly below. Other 75 mc. *fan shaped* beams will project upward from mountain ridges or at stations thirty miles from the airport to warn the pilot or tell him ten minutes in advance that he is approaching his terminal field.

The second ultra high frequency facility will be the instrument (Blind) landing system. Already demonstrated experimentally, production models for training purposes are the next step. When a sufficient number of pilots have been trained and unquestioned reliability has been established through the training and test period, commercial adoption will follow. Two types of 100 megacycle beams are used in this system. One provides a horizontal path down the landing runway for left and right guidance. The other is a curved beam which rises gradually upward to provide a path down which the descending plane will glide. By fortunate circumstance nature made reflection from the earth's surface in such a manner that it adds to the projected horizontal beam and forms almost exactly the



H. M. Hucke, United Air Lines chief communications engineer, a leading expert in aviation radio developments predicts that we shall shortly be using ultra high frequencies for communicating with as well as guiding aircraft.

proper gliding angle for a descending airplane.

In a few years *ultra high frequency* airport control transmission and reception will replace the 278 kc. channel now used for this purpose. The continued addition of new airports in metropolitan areas such as San Francisco or New York within the past few years has tripled the need for additional channels. No suitable channels adjacent to the present frequency are available, hence the change to ultra high frequencies near 130 mc. where there is room for expansion. Traffic at Chicago Airport has increased to a point where a transport plane takes off and lands every three minutes during rush hours. Airport designers are visualizing double runways with two  
(Continued on page 636)

Fifteenth of a Series of "Guest" Editorials.



Left—New rotary antenna system in use at PCJ. Center—Miss "Patience," NBC television model who never fires—she's a dummy. (No relation to Charlie McCarthy.) Right—English television receiver.

# Short Wave Pictorial

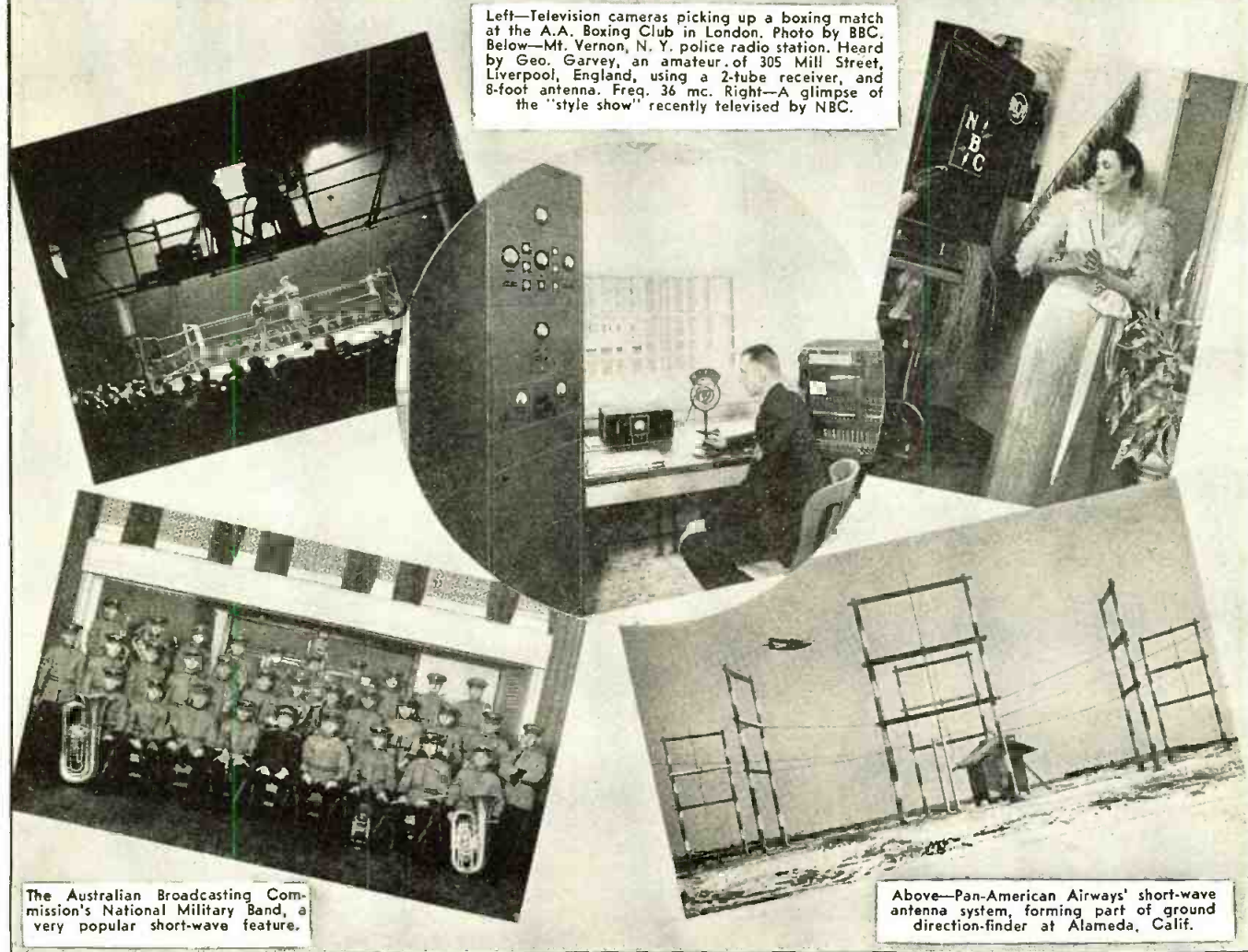

Left—Television cameras picking up a boxing match at the A.A. Boxing Club in London. Photo by BBC. Below—Mt. Vernon, N. Y. police radio station. Heard by Geo. Garvey, an amateur, of 305 Mill Street, Liverpool, England, using a 2-tube receiver, and 8-foot antenna. Freq. 36 mc. Right—A glimpse of the "style show" recently televised by NBC.

The Australian Broadcasting Commission's National Military Band, a very popular short-wave feature.

Above—Pan-American Airways' short-wave antenna system, forming part of ground direction-finder at Alameda, Calif.



# You Can "SEE" Over This Telephone Line Between German Cities

Somewhat similar to the television system demonstrated about six years ago by the Bell Telephone Labs., in New York City, this new German telephone system carries the images as well as the voices of telephone subscribers.

● SOMEWHERE around six years ago the Bell Telephone Laboratories demonstrated television over a telephone system to hundreds of people in New York City, the images being carried over a special circuit

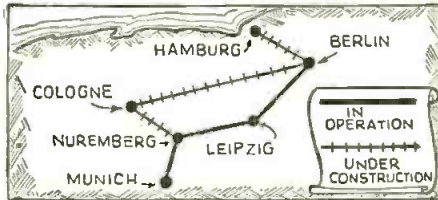

This map shows the great distance covered by the new German telephone-television system, cities over 100 miles apart being connected by this wire network.

connecting the Bell Telephone Labs. with a building approximately four miles distant in downtown New York. With improved transmission efficiency and new scanning apparatus, German telephone subscribers by paying a special fee, are now able to talk with and actually *see* the person at the other end of the telephone line, between cities like Berlin and Leipzig. A special booth is used wherever this service has been made available to the public and new infra-red lamps illuminate the person's face; this light although invisible to the human eye, when reflected from the face will cause the sensitive photo-electric cells to register the varying degrees of light and shadow. These cells convert the different degrees of light into electrical impulses, which are carried over the television circuits; the television image signals are transmitted over co-axial cables.

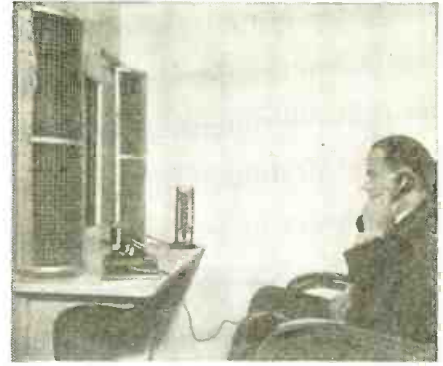

Above—The sound-vision booth at Berlin. As you talk to the person at the other end of the line you see his image as well as hear his voice.

This new *voice-image* phone service has been extended to Munich and auxiliary lines to Hamburg and Cologne are under construction. Thanks to the newly designed scanning drums, which are fitted with a new type of lenses instead of ordinary holes, the amount of light required to scan the subject has been markedly reduced. The scanning drums are, of course, driven at synchronized speed at all television-telephone station booths and are checked at regular intervals. One of the photos shows an

(Continued on page 636)

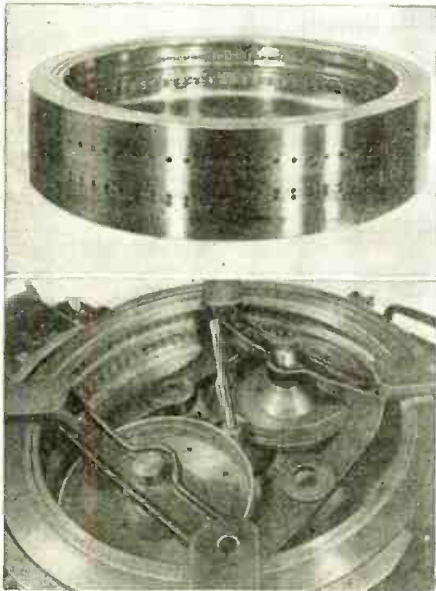

Here is the special scanning drum, which is fitted with lenses.



Above—Actual reproductions of the television images of two persons telephoning to each other, as observed on the monitor in the telephone exchange.

## How You Hear Short-Wave Programs From Europe

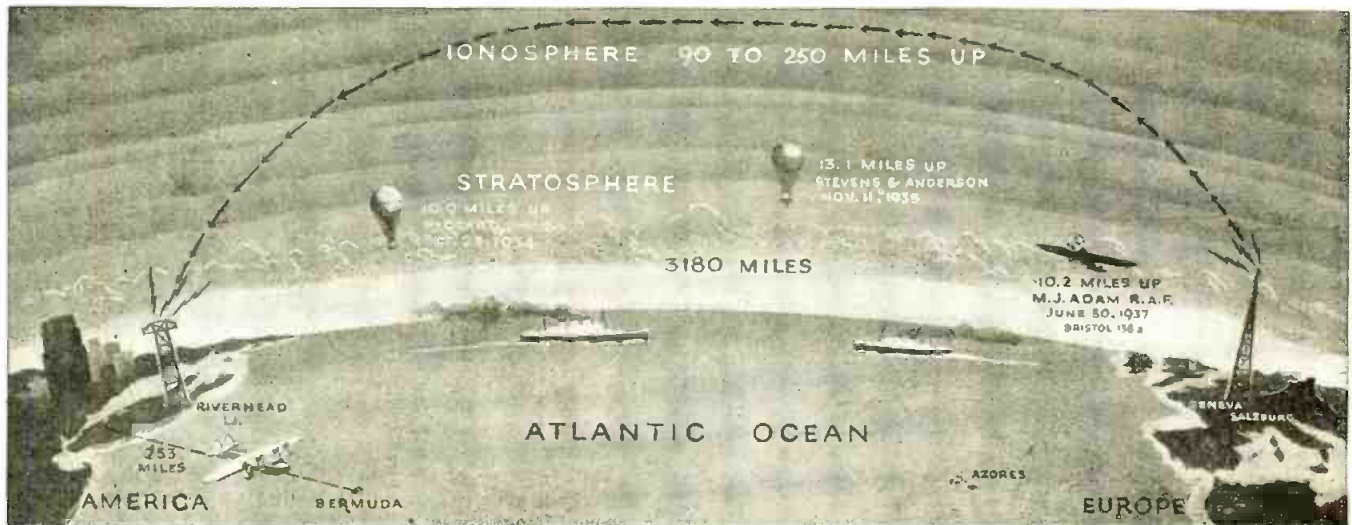

● The picture above shows how short waves traveling through the ionosphere, 90 miles and more above the surface of the earth, brought the great Salzburg Festival to America. This picture shows, in general, how other European programs are carried

across the Atlantic to American broadcast listeners. The National Broadcasting Company handled 698 Foreign broadcasts last year from 51 countries, beside maintaining a regular *program* service to Latin America. At least 2 daily programs are exchanged.

# First U. S. Television Station on Wheels

With a range of 25 miles, this new NBC television mobile station will be used to pick up spot-news events, and relay them to a pick-up station by ultra-short waves for rebroadcast.



Above—View atop one of the television vans recently constructed for the National Broadcasting Company. The engineers and announcers are in the act of assembling the iconoscope television camera and the parabolic microphone.



Right—The iconoscope camera in operation; it can be swung quickly in any direction.

Below—Inside one of the vans, showing the image monitor panel. All apparatus is mounted in neat cabinets provided with doors.

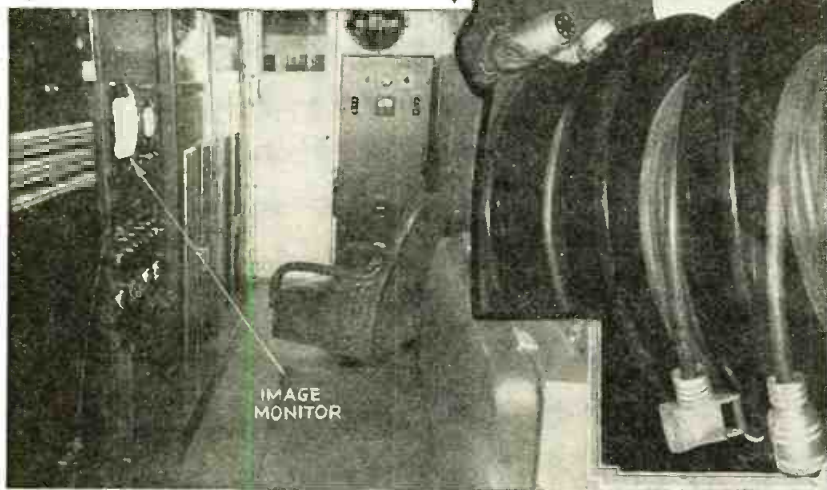

Above—The complete mobile television station! The image and sound pick-up van is in the foreground. The transmitter van, connected to the front truck by coaxial cable, is fitted with a telescopic ultra short-wave antenna.

Left—Coaxial cable reels.

Right—Close-up of coaxial cable terminal on side of television truck.

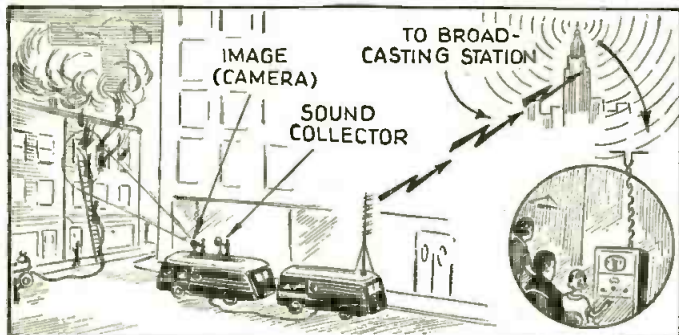
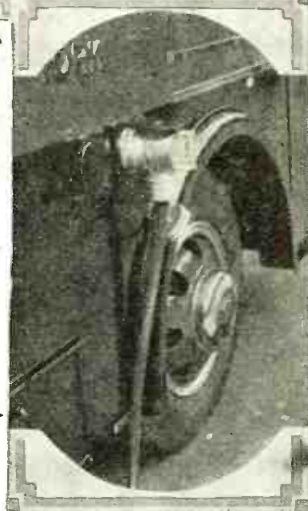

How mobile television station will pick up "spot-news" events and flash both image and sound to a pick-up station.

● AMERICA'S first mobile television station, to be used by NBC engineers in experimental pick-ups of *outdoor news events*. The two large motor vans, latest development in RCA television, are connected by coaxial cable when in operation, and contain complete apparatus for picture pick-up and transmission with

accompanying sound. One, mounting the pick-up apparatus, provides operating positions on the roof for Iconoscope cameras and special parabolic microphones. The other, the transmitter, has a special *trolley* antenna which may be used to relay the broadcasts to Radio City. The unit will be operated in connection with the present experimental television transmitter atop the Empire State tower.

"The public," said O. B. Hanson, NBC chief engineer, in outlining the work to be done with the mobile station, "will expect television to bring distant current events into the home. In addition to studio productions, it wants such things as presidential inauguration ceremonies, political conventions, football and baseball games, boxing matches, fashion parades and all the shows we now class as special events.

"Through radio it has heard descriptions of all these; sometimes the sounds of the events themselves. What the American public will eventually demand is that television bring faithful sound and image reproductions of all into the living room.

"This new mobile unit, the first in America, will enable us to make a start toward supplying that demand. In taking television outdoors we expect to learn much about the sensitivity of our instruments."

(Continued on page 656)

# Short Waves Guide Planes

## Between Europe and South America

W. E. Schrage

Elaborately equipped "floating radio stations" serve as refueling bases for long-distance air-mail planes.



The elaborate short and long-wave radio equipment aboard the floating hotel "Friesland" by means of which mail planes are guided. Six receivers cover all waves between 15 and 20,000 meters.

● DOWN in the South Atlantic, about 600 miles off the African coast and about the same distance from the South American coast, two lonely steamers of unusual design circle endlessly around certain spots, for weeks and months. Each of these ships has a tonnage of approximately 8,000 and carries a crew of sixty. The main purpose of all this effort is to provide guidance and "haven" for the airplanes which carry mail between Europe and South America.

For the moment let us disregard the "harbor-facilities" extended by the air-mail mother ships, and examine the guiding service provided by these two vessels for one need not mention

Two floating radio and refueling ship stations are stationed between Europe and South America, at 1 and 2, so that mail planes can stop and refuel. Short waves guide the planes over this route.

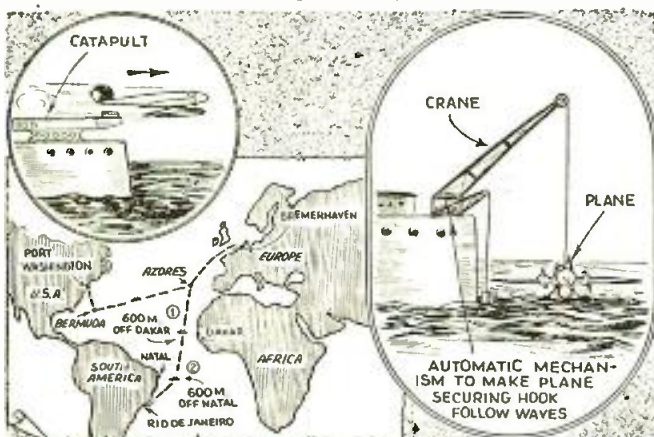

The deck of the first airplane-hotel ship, with large crane for raising plane from water. Note the catapult at the right.

that the most important factor in bringing the mail planes safely over the long ocean route is *radio*.

Without the aid of radio all the excellently designed launching and landing facilities would be useless, when unfavorable weather reigns over the South-Atlantic. No wonder that great care has been given to the design of the radio equipment installed on these vessels. This intercontinental mail service has now been in operation for about 2½ years, and all the experience gained in this time has been used advantageously in the planning and design of a new *floating-radio-station*, the first ever built exclusively for this purpose. All the other ships of this type were simply old rebuilt freighters.

The new *floating island* of which we show a number of photos on this page has been christened *Friesland*. It has a very powerful radio station equipped with the finest transmitters and receivers money can buy. A 3-kilowatt long-wave transmitter of very recent design covers the wave range from 600 to 3000 meters. Although this wave range is of great importance for all maritime and avia-

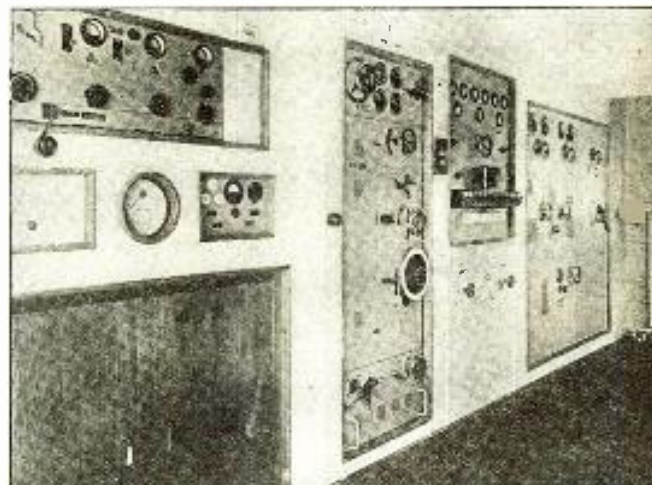

The two S-W transmitters are seen at left of photo and the long-wave transmitter at the right.

tion services, most of the traffic is handled by a considerably smaller transmitter of 600 watts, operating in the short-wave range from 15-90 meters. In order to make this short-wave link fool-proof, an auxiliary transmitter of 150 watts output operating on the same wave range is at the disposal of the radio operators. There is also an emergency transmitter which is operated entirely by batteries.

The reception equipment of the radio station of the *Friesland* is equally well designed. Six receivers are available, covering the wave range from 15 meters up to 20,000 meters, some of them operating exclusively on the short-wave range only. There is ample space provided in the radio station to permit three operators to handle traffic simultaneously. However, most of the time only two radio operators are on duty. (Continued on page 631)

# New Experiments With Radio

## Motor Built From A.F. Transformer

● MANY of us have, at one time or another, desired to build a small A.C. motor such as that used for operating electric clocks. How such a motor may easily be

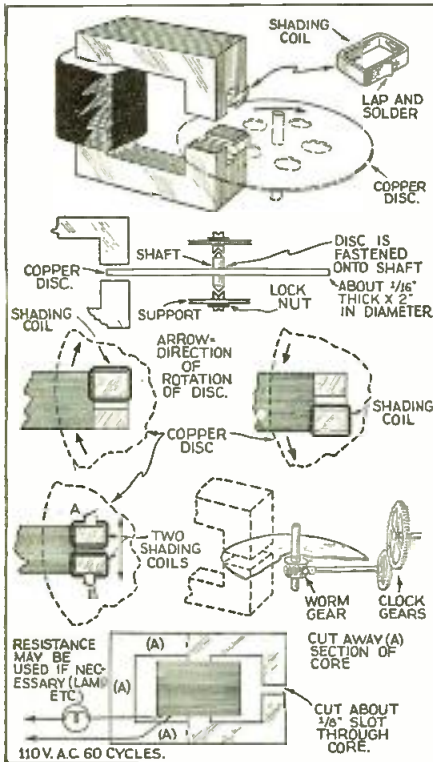

How to construct small A.C. motors from A.F. or other transformers.

built from a disc of copper or aluminum about 2" in diameter is here illustrated. The laminated iron core may be obtained from an old A.F. transformer and if the builder intends to wind a new coil the core may be picked up for a few cents from a radio store or probably be had for the asking from any radio experimenter.

In some cases where both coils are of low impedance you may find it advisable to connect them in series, so as to obtain sufficient impedance to prevent the windings from overheating.

Where they are of high impedance on the other hand, the two coils may be connected in parallel to give a stronger magnetic field in the iron core. In either case try transposing the coil leads until the motor shows the greatest speed, denoting that the coils are connected so as to aid and not buck each other.

As the drawing shows the motor is made self-starting by cutting a slot in the top and bottom pole of the iron core and placing shading coils in the slots. The coil may consist of a piece of copper or brass wound around half of the pole as shown, soldering the lapped ends of the coil. Make

sure that it fits tightly around the core so as not to move up or down. The revolving copper (or aluminum) disc is rigidly mounted by soldering or otherwise to a small shaft arranged to rotate between two pivot screws.

By winding two shading coils on the top and bottom pole-faces of the iron core as shown at B, and providing switches to short-circuit one or the other of the coils, the motor may be made to start in either direction. The disc will start rotating in a direction pointing toward the pole containing the active shading coil. The unused part of the iron transformer core is cut away as indicated. If the winding on the transformer should happen to overheat, a small 110 volt lamp may be connected in series with it, or else another transformer winding or a resistor may be used instead.

## Motor Speed Regulator

● A GREAT many radio experimenters have some old iron-core choke coils or transformers lying around their workshop, and these can be used very nicely for regulating the speed of a small motor.

As the diagrams show the choke coil is connected in series with the 110 volt A.C. line feeding the motor. For A.C. circuits these choke coils, especially where they can be made adjustable, are ideal for the purpose in question. They may also be connected in series with D.C. motors, but no advantage is gained except that of convenience; ordinary resistance coils are usually employed for D.C. regulation.

Several choke coils may be connected in series to give a greater range of speed regulation or current control to the motor as shown at D. A very smooth and gradual control of motor speed may be obtained by arranging the iron core to slide in and out of the choke coil. Another way to provide regulation is to slide a copper or brass tube over the coil as shown at A.

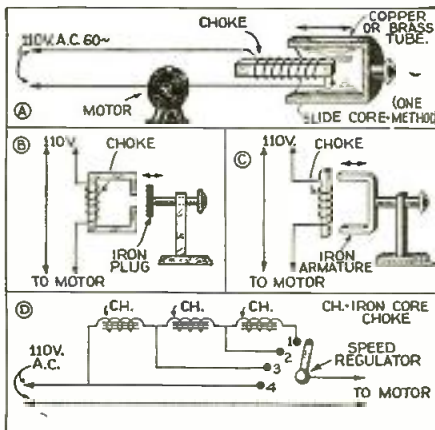

Old iron core choke coils come in handy as speed regulators for small motors.

Figures B and C illustrate two other methods of providing regulation by means of choke coils, a piece of iron core being moved toward or away from the air gap in the core at B, while at C a section of laminated core is moved back and forth in relation to the iron core of the choke coil. The closer the moving iron is to the gap, the higher the reactance of the choke coil and the lower the speed of the motor.

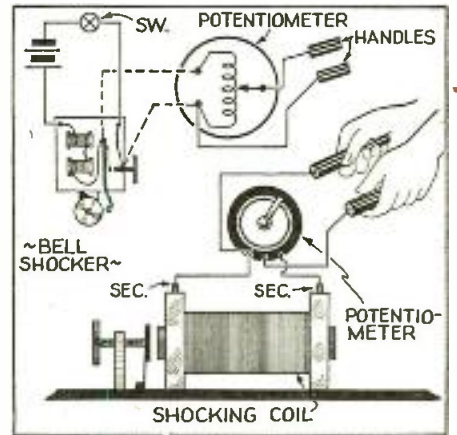

Potentiometers prove useful for regulating the voltage of shocking coils.

## Potentiometers as Current Regulators

● POTENTIOMETERS are not new to electrical experimenters, but have come into greater prominence through their wide adaptation to radio circuits. Two interesting applications of potentiometers for current control are shown above. Many experimenters may not be aware of the fact that a substitute for a shocking coil is an ordinary vibrating bell, and the larger the bell, of course, the greater the kick one receives from it. The connection of a potentiometer of about 10,000 ohms or so resistance, to regulate the degree of shock administered through the metal handles is shown in the diagram.

The old method of constructing electro-medical or shocking coils fitted with a vibrator, for operation on a couple of dry cells, involved the use of a sliding brass tube which could be moved in and out over the iron core. By using the method shown a shocking coil may be made up from a number of different coils that an experimenter may find in his junk box, such as old telephone induction coils. A vibrator is fitted to one end of the coil and to regulate the degree of the secondary current administered to the patient, one has simply to turn the knob of the potentiometer, as becomes apparent.

A somewhat higher resistance value will prove useful for regulating the voltage from the shocking coil and a potentiometer of 50,000 ohms or so may be used.

# Apparatus

Say, fellows, this is your department! Let's hear from you. Cash prizes will be paid for brief descriptions and sketches or photos of your non-radio applications of radio apparatus. Sit right down and write the editor about that novel idea you worked out!

## Simple Burglar Alarm

● ONE of the simplest burglar alarms is that which utilizes the *hand-capacity* effect which all of us have noted in connection with simple regenerative receivers. The receiver is adjusted by rotating the tickler coil until it is in an oscillating condition or just below this point. Now when you touch a metal plate or other connection joined to the grid circuit of the tube, it will *spill over*; this fact being manifested by a signal in a sensitive loudspeaker or a pair of phones connected to the tube. Where a stronger signal is desired, the output of the tube may be connected to a one or two stage V.T. amplifier. By having the metal plate connected with the grid circuit, hidden among silverware or other valuables, the approach of a thief's hand may be registered by a squeal from this *radio detective*.

A great deal of fun may be had with a circuit of this type at parties and other affairs, by concealing the capacity plate under a table cloth, etc. The coils can be wound on a cardboard tube and the tickler arranged to be rotated at one end of the grid coil tube, as shown in the drawing. A small by-pass condenser connected across the phones or loudspeaker will usually make the set work much smoother.

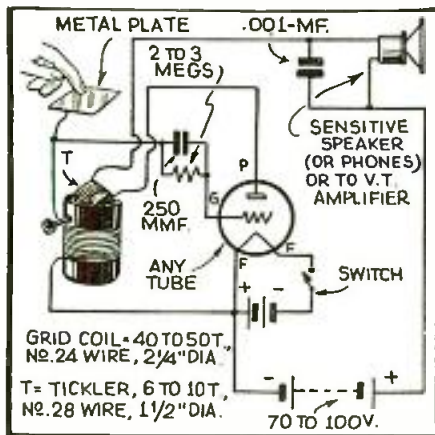

Simple burglar alarm built around a regenerative detector circuit.

## Interference Eliminator

● ELECTRIC motors or devices using a vibrator often cause severe interference on radio receivers in their immediate vicinity. One method of eliminating such interference from electric motors is to connect a couple of condensers in series (of the mica or paper type and rated at least 100% above the line voltage) with the center-tap between the condensers grounded to a water pipe or other satisfactory ground. It is well also to ground the frame of the motor by connecting a piece of wire from one of the bolts securing the motor to a water pipe or other ground.

The size of the condensers may be experimented with and for large motors big-

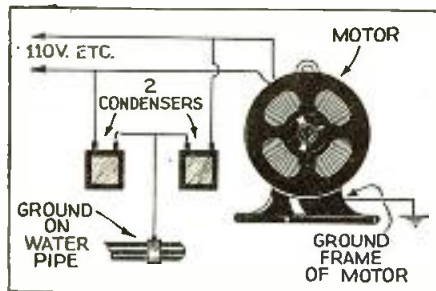

Interference noises heard on many sets are often caused by motors. Here's a simple cure.

ger condensers will be required than for a small fractional horse-power unit. From 0.1 to 1 mf. capacity condenser units may be tried for eliminating interference caused by small motors, such as 1/10 to 1/6 H.P. As the electric waves or parasitic currents set up on the line from the motor are liable to leak into other circuits before they are dissipated, therefore the condensers should be connected close to the motor.

## MONEY FOR YOUR IDEAS!

Each month we will award 2 prizes, the first of \$10, the second \$5, for the best **NON-RADIO** uses of ordinary radio parts and radio instrumentalities. Hundreds of different ideas may be adapted for this contest; the editors will be grateful for your ideas.

## Induction Balance

● MANY interesting experiments may be carried out with an induction balance such as that shown. The four coils should

be wound on exactly the same size forms, made of cardboard or other tubing, or else machined in a lathe from a piece of wood.

The next important point is the fact that each of the four coils should be wound with *exactly* the same number of turns, about 150 turns of No. 32 or 34 silk covered magnet wire or its equivalent. The reason for doing this is to make sure the bridge is balanced, so that no sound will be heard in the headphones connected in series with the secondary coils.

As a source of exciting current for the primary coils a vacuum tube oscillator may be used. The original balance of Hughes employed a battery of a few cells connected in series with a microphone as shown in the diagram. Some source of interrupted sound such as the ticking of a watch or clock was then employed, and the position of the coils with respect to one another was adjusted until no sound could be heard in the headphones. If a piece of iron or other metal is placed in the field of one of the coils, you would again hear the sound of the ticking watch in the phones.

Present-day radio experimenters have probably done very little with the induction balance, but many interesting new discoveries and experiments are to be made with it. The diagram shows one variation of the balance which will give experimenters an idea for the possible development of a new and improved type of *ore and pipe locator*. Here a two or three stage vacuum tube amplifier is employed to boost the differential current in the secondary. Also a meter may be connected in place of the phones so as to give a *visual* indication of changes in the circuit, denoting the presence of metal in the vicinity of the coils of the balance. A buzzer is sometimes used as a source of excitation current for the primaries. Note that no iron or other metal screws or parts should be used in building the balance—only wood or other non-metallic materials.

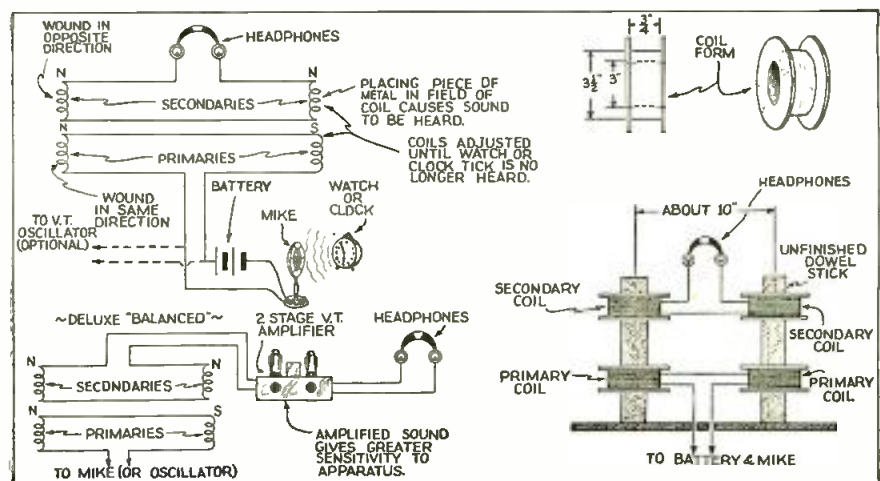

Radio parts come in handy for "induction balance" experiments.



Short-wave listening den of Les Smith of Somerset, England.

### We Have a Friend in England

Editor,

Herewith a photo of my "shack" in London. I am corresponding with quite a number of members in different parts of the world, and I will answer all letters received from English-speaking listeners.

My receiver is a three tube, detector, audio and power stage, and is home-constructed. I have 87 veris which include 24 countries verified, and two veris from each of the continents.

I have managed to pick up several issues of *Short Wave and Television*; they have the English magazines beat for the information given on short-wave radio news, etc.

LES SMITH,  
"Inglefield," Fivehead,  
Nr. Taunton, Somerset,  
England.

### He Likes Our New Cover

Editor,

The cover on the January, 1938, issue of *Short Wave and Television* looks like something now; keep it up!

I agree with Dickson Witman in part of his article, television doesn't make good S-W news at the present time, as it is too costly and at an early experimental stage. I also believe that SWL's and "hams" could dispense with some of those S-W medical appliance articles, as I can't see how anyone could get short wave stations on them. This would allow more pages to be devoted to doings of interest to SWL's and "hams."

I would like to see more articles dealing with what other SWL's are doing, and since they and the hams are customers of this magazine, why not devote it to such?

I would like to see advs. dealing with inexpensive barometers that are offered for sale, since SWL's and hams give weather reports in their station reports.

I would like to see an article dealing with sun-spots (solar eruptions) and its effect on the ionization layers and what its effects are on S-W transmission and reception. As yet I have seen nothing on this subject in my radio magazine, yet my foreign mail seems to be generally on this subject.

"Reader comments" make a magazine, so excuse this criticism if I seem too severe.

### Listen to This, Mr. Feige!

Editor,

Here's an SWL's answer to that old crank, Charlie Feige, Jr.:

If Charles will notice his *Short Wave & Television* Mags. more closely, he will see quite a number of SWL's in the ham

shacks, whose pictures appear in every issue. Any ham who can get his picture in a magazine as good as *Short Wave & Television*, must have a first-class station. Feige must have a dumpy place, with no SWL's and no photos to submit to this magazine.

In the lower left-hand corner of "our mag." for January, 1938, page 478 (in the same issue in which his hot air appears), he will see a photo of a FB ham shack with numerous cards on the walls. If he will inspect this photo carefully he will see that SWL's make up quite a few of these cards. These don't look as if they had ever seen a wastebasket. This is just one photo; there are hundreds of others in previous issues.

Besides all this "uncontrollable oscillation," he complains about breaking laws. We are to assume, I suppose, that this crank never broke any laws. Anyone that good should command a high position. Every one I've ever met, has at one time or another, broken some law. And take it from me, brother, I've met plenty of people.

Let's hear whotinel this guy says to this.

CAREY W. SULLIVAN,  
506 Ohio Street,  
Georgetown, Ohio.

P.S.: I am for SWL's and *Short Wave & Television* one hundred per cent. Is Charles Feige, Jr.?

### He Doesn't Agree with Tesla

Editor,

Regarding the article concerning "Nikola Tesla's Opinion on Martian Communication," published in December, 1937, issue

ROY E. CHISHOLM,  
President.  
Jackson Short Wave  
League,  
616 Fourth St.,  
Jackson, Mich.

(Thanks, Roy, for the suggestions. We shall endeavor to publish an article on the sun-spot effects at an early date. *Television* is coming along rapidly and we think you will find our articles timely and valuable.—Editor.)

of *Short Wave & Television*. Quoting from the second paragraph, "Dr. Tesla's interpretation of these signals was that they spelled out 1-2-3-4, etc. It is his opinion that if these signals had been sent by Martians, they had used numbers in an attempt to establish communication with the earth, for the good reason that numbers constitute a very broad universal language."

This is the most ridiculous statement I have seen in a radio publication, and I am surprised that a man with Dr. Tesla's accomplishments should allow his name to be linked with same.

We are led to believe the supposed Martians had mastered the International Morse Code sufficiently to send numbers! This statement was probably meant for "Amazing Tales" magazine, instead of a technical radio publication.

Yours for facts and less suppositions.

R. T. WARNER,  
Box 448,  
Victorville, Calif.

(Thanks for your opinion of Dr. Tesla's interpretation of the mysterious signals which he heard and which he suggested might have come from Mars. We wish to

# Uncontrolled Bouquets and Brickbats

receive many more letters like yours to liven up this department, and we are sure that all of us will enjoy such controversial opinions very much.

We don't know how many books on astronomy and the scientific possibilities of the inhabitation of such planets as Mars you may have read, but after all there is at least a possibility that some distant planet may support life in the form of an intelligible being.

You say in your letter "This is the most ridiculous statement—" but do not mention any logical reasons why you think these statements are so far-fetched. While we do not have the space to publish long letters in this department, we would like to have expressions of opinions on such subjects as the Mars communication possibility in which some technical reasons are given for the writers' disagreement with the theory set forth. So go to it, readers, and if you disagree with any of the theories given by any of our writers, let us have your version of the opposite side of the story.—Editor.)

### He Saw RCA Television and is "Rarin' to Go!"

Editor,

I want to express my thanks to you for publishing such a fine magazine.

A great deal of listening is done, here, mostly on the 10 and 20 meter amateur bands. When listening is done on the other bands, your World S-W Station List and Joe Miller's column is used to advantage.

Several receivers are used, both super-hets and regenerative jobs. Usually in operation is a new five-tube regenerative set, which has a very low noise-level for this location.

On this set alone, four hundred amateur stations have been logged in the past four months.

Four antennas are used, covering from 550 kc. to 60 mc., they are controlled by two switches, and within four seconds I can change from one to the other.

Very recently, I had the great pleasure to be able to attend a special demonstration of the RCA television system, viewing both the sulphur-yellow and white screens. The white, a recent development, is the better. The images formed were of remarkable clarity and steadiness. In my humble judgment, they compared with "home movies," having no flickering as some home movies are prone to do. In the past 18 months, television has taken great strides.

To get back to your magazine, most of the television articles have been on the European situation and they clearly show the progress over there.

But the situation here in America has not been given very extensive treatment. I believe that it is more advanced here than in Europe.

Personally I would like to see a series

QSL when correct reports with postage are received. In two years as SWL here, only 55 per cent of amateur reports (all with postage or I.R.C.) have yielded a reply. So for the SWL who offends with a meager card, I give Mr. Feige the amateur who disregards *deserving* reports, and where the offensive SWL "QSL" only provokes the amateur, the conscientious SWL suffers a monetary loss of approximately seven and fifteen cents respectively, for discarded reports to local and foreign "hams."

M. W. SOPLOP.  
Alleghany, New York.

### From the Oldest S.W.L. in Cape Breton

Editor,

Since 1931 I have been a steady reader of *Short Wave & Television* and have built many receivers described in its pages.

From the *Uncontrolled Oscillations* department I have received many addresses of short-wave fans and have traded "shack" photos with them. Joe Miller's page is very interesting; I have logged very few ham stations and go mostly after the short-wave broadcast stations.

many a well-meaning lad from going after a ticket, or even becoming interested in the largest profession in the world today, calling us a *neophyte*. Sure we are, but does he know the meaning of the word? Two-bits he doesn't.

I suppose he went to some great school to study the art of *ham* radio. If not, where did he learn it? From some poor ham who fell the victim of an egotistic eel.

I have several mighty fine friends who have been in ham radio for years and have received hundreds of QSL cards from both hams and SWL's, and they are not afraid to display the SWL "QSL" cards any more than the cards received from amateurs.

Of course it takes all kinds of people to make the world go around, and he happens to be one kind, but thank heavens, there are plenty of real hams to his one.

He says the SWL cards always give R9 reports; well I can refer him to many an amateur who has received a card from me, and which had only a QSA2,R3, and they've never made a squawk about it either.

Naturally all amateurs would like to have their cards read "worked" but those who are really human will also be glad to see some fan interested enough to drop them a card, even if it does say "heard"!

This N2DDV may have been in radio for seventeen years, but he hasn't become too old to be told a few things yet, and I am one Irishman who can tell him more than he has ever learned in the Navy.

I happen to be a soldier myself and have received a few medals, but that is no reason I should get high-hatted.

I am only a poor devil trying to get along in this old universe and some day (the Lord permitting) I will have enough coin to build a station and when that time comes I will go get my ticket and go on the air. But if N2DDV knows what is good for him he won't give me a call because if he does, the air waves will probably get a scorching.

*Short Wave & Television* is a grand magazine and I keep after the mailman around the latter part of the month, for I can hardly wait to get my hands on the  
(Continued on page 650)

# Oscillations

from Our Readers

of planned writings on the subject, which would go into detail and really discuss the systems in use here in America.

Also a series of constructional articles, on the building and operation of a really efficient television receiver, which could be used by those in the range of a transmitter (namely near New York and Philadelphia), should capture the interest of all, that like to explore and experiment in new fields. Such a receiver using a five or seven inch cathode tube, would cost around one hundred dollars. I believe that many would become intensely interested, more than they are now, in experimenting with television.

RICHARD AIRHART,  
1014 Chestnut St.,  
Roselle, N.J.

Some months ago I became the owner of the handsome new Hallicrafter receiver shown in the photo.

Many thanks for your helpful magazine and the wealth of information given in all the various departments each month.

FRED BAINES (the oldest "SWL" in Cape Breton),  
c/o Baines Bookstore,  
Sydney Mines, Nova Scotia.

### Who Said Hams Didn't Want SWL's QSL Cards?

Editor,

Who is this guy N2DDV, who has such a dislike for the SWL's, just because he can put an "N" in front of his call, instead of a "W," and adds a "RM1c" to the end of his pan-handle?

I suppose he never was an SWL, or sent an SWL card to some of the brethren of the air waves.

It is fellows like him who are keeping



Fred Baines of Sydney Mines, Nova Scotia, the oldest "SWL" at Cape Breton.

### Mr. Feige's Complaint Partly Justified

Editor,  
The indictment of QSL "hounds" by Charles Feige, Jr., in the January issue needs no "biting" retort from the SWL front, inasmuch as his remarks for most part are justified.

The SWL "QSL" does not afford sufficient space for a complete and accurate report of an amateur's signal! Reports on SWL cards such as Mr. Feige describes are not deserving of a reply, for it must be remembered that the amateur's QSL is not to be merely "collected" but earned by correctly reporting his transmissions and enclosing postage or an international reply coupon.

On the other hand, to further a grievance of the SWL fraternity, Mr. Feige must admit that many amateurs will not even

# A 441-Line Cathode-Ray Television Receiver for the Experimenter

C. W. Palmer, E.E.

● A RECENT change has taken place among those who control the slow and tortuous progress of television behind closed doors. Up to a few short months ago, these Moguls of the research laboratories treated every attempt of amateurs to cope with the television problem with scorn. Their answer has been that the design and construction of television receivers, even at this point in the development cycle, is much too complex for even the advanced radio amateur.

The important change is the announcement made by two large manufacturers of cathode-ray and television equipment that they will market television receiving tubes (not oscilloscope tubes adapted to the problem) and associated parts such as power-supply transformers, sweep coils and such parts as essential kits for home constructors.

The significance of this change is not at first apparent. However, a little thought on the subject discloses the important facts that; first—television is at last at the point in its development where research engineers feel that a practical receiver can be made which can be used in those localities where there are experimental transmitters in operation, and secondly, that the "powers that be" in the television field have at last acknowledged the fact that without the help of amateurs, home constructors and independent workers, the possibility of television becoming a realized fact in the U. S. is very remote.

A little explanation of the latter statement may be in order at this point. It is a well known fact that the main reason why television has not turned the well known "corner" is that no one corporation or advertising interest is willing or able to put up the huge sum which would be required

to make "network television" a reality. Without tying up the various stations in the principal cities of the country in a manner similar to the radio broadcasting networks, there would soon be a lack of talent and no real progress from a commercial standpoint could be made.

The only way that such networks could grow would be through the demands of *John Public* and it is in an effort to start such a wave of public interest as started radio broadcasting on its scintillating career

**The "S. W. & T." television receiver has been especially designed by Mr. Palmer for picking up the 441-line images now being broadcast experimentally in several cities. One section of the receiver is assigned to the job of picking up the sound. The whole design is very flexible, thus permitting the reception of images with different scanning sequences.**

that these television kits are being introduced.

### Good Television Parts Available

However, entirely aside from the big business reasons for the marketing of these television parts, the fact remains that it is now possible for the *amateur television enthusiast* to get "honest-to-goodness" television parts from which a viewing set can be made which will rival the results obtained by the television broadcasters in their so-called private demonstrations.

The construction of a television receiving set using the special parts now obtainable is not nearly so difficult as it might at first seem — any advanced amateur radio constructor

who has some knowledge of the operation of a cathode-ray oscilloscope, and who has used equipment operating with high voltages, can make a successful television set, provided the distance from the nearest television transmitter is not too great.

With these facts in mind, the author was given the problem of designing and constructing a working model of such a set which can be used by television experimenters as a guide in building similar sets for their own enjoyment and as a basis for experimenters to use in their efforts to find the "ideal television system."

This design problem was a "large order" and one which required and is still requiring a great deal of research and thought. Many different types of receivers had to be checked over before the most suitable one for this particular set could be chosen. The set has to have good sensitivity on the wavebands used for television transmission; it has to have an extremely wide band-pass—over 2 million cycles—yet the gain must be sufficiently flat over this wide band to prevent excessive R.F. distortion of the signal waveform. The set must have high gain, a difficult job on the frequencies at which it must operate—even with a superhet circuit, due to the high intermediate frequency necessary to pass the wide vision band. The noise level must be unusually low as tube noises and even static are more annoying to the eye than to the ear.

### Detector of Special Design

The detector must be of unusual design also, as it must supply a wide variation of demodulated signal voltage without introducing phase or amplitude distortion. And, while the cathode-ray tube is purely a voltage-operated device, any video amplifiers that are used (the video amplifier is similar in operation to the audio amplifier of the sound receiver) are advisably of the power type in order to handle the wide voltage swings required to modulate the television type cathode-ray tube.

The power-supply circuits must be carefully designed to supply constant voltages without hum ripple, both to the receiver and the cathode-ray tube. The wide variation in voltage and power required for these two  
(Continued on page 645)

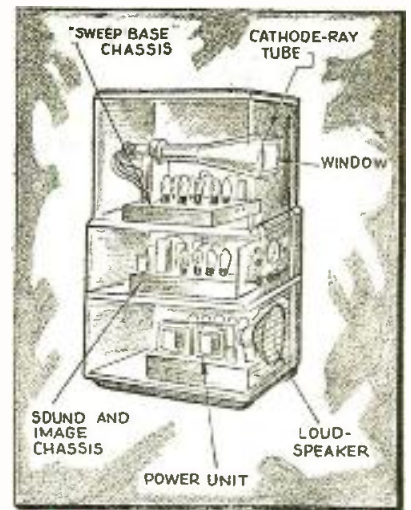

General arrangement of image and sound units in "S.W.&T." 441-line Television Receiver.

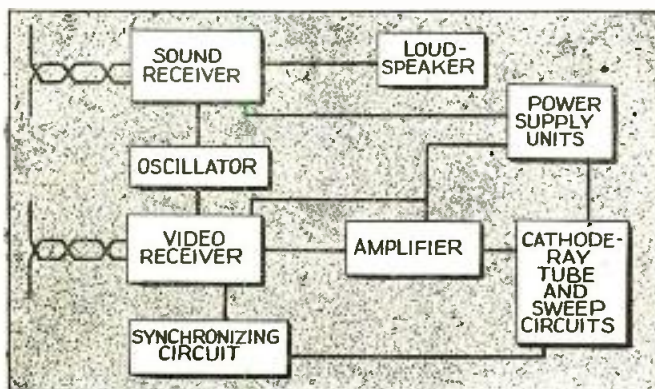

Block diagram of "S.W.&T." Cathode-Ray Television Receiver.



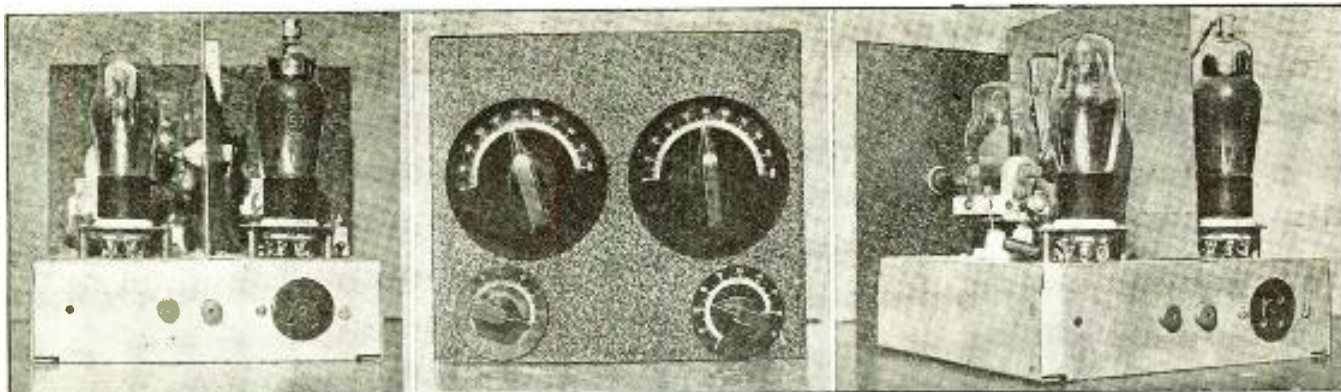

Three views of Mr. Popenoe's 5-meter T.R.F. receiver, which has given excellent results.

# A Good 5-Meter T.R.F. Receiver

Paul Popenoe, Jr.

● WITH the advent of new highs in five meter amateur communications many amateurs are looking forward to new receiver design. The increase in activity makes it impractical to use the regular self-quenched super-regenerative five-meter receivers except for portable use. When a T.R.F. stage is added, however, the efficiency of the set is increased and radiation eliminated. Radiation has always been a serious drawback of the straight super-regenerative type receivers. In due consideration of the other fellow, let us have non-radiating receivers 100%. Of the non-radiating receivers the T.R.F. may not be as good as the super-het, but dollar for dollar it is very hard to beat.

This T.R.F. receiver is simple and inexpensive. The circuit is not tricky, and the set can be built by anyone. The set uses glass tubes, and the line-up is as follows: a 58 R.F. tube, a 56 detector, and a 2A5 audio. If the builder so desires he may use 6D6 for the R.F. stage, 76 detector and 42 audio.

When looking at the front of the panel the line-up is as follows: On the upper left is the R.F. tuning, below is the audio volume control. On the upper right is the detector tuning control and below the regeneration control. Vernier dials are not used as they are not necessary. If they are used tuning will be rather slow.

The base construction of the set is simple. It consists of a 7"x7"x2" chassis, a panel 8 inches wide and 7 inches high, and an inter-stage shield 5½"x7 inches. The shield is mounted on the chassis running from the panel to the back of the chassis. On one side of the shield is the R.F. stage, and on the other side are the detector and audio stage. Isolantite construction is used on the variable condensers, which are mounted on stand-off insulators, to minimize R.F. losses. The coils are mounted on stand-off insulators for convenience. The sockets for the detector tube and the R.F. tube are steatite mounted on spacers, while the socket for the audio tube is bakelite mounted under the chassis.

The R.F. stage is coupled to the detector by a fixed condenser tapping the detector

Many S-W Fans and Hams have asked for a good T.R.F. receiver for 5 meters. This one is simple, inexpensive and non-radiating.

coil at about the third turn from the grid end of the coil, but the tap must be adjusted to maximum coupling. An alligator clip will prove to be the best means of coupling the R.F. stage. For those who wish to use a trimmer condenser and a fixed tap a 3 to 35 mmf. will work well. In order to save space the audio stage is resistance-coupled.

From the foregoing paragraphs I believe the reader will be able to wire up the set

by simply following the diagram, the photographs and the parts list. The diagram is simple enough for the beginner, yet it is good enough for the old-timer.

Tuning is simple, but will require a little practice. The set is tuned up as follows: First adjust the regeneration control, which is in series with the B+ of the detector, to a low hiss level. Next tune the detector until a signal is received. Then tune the R.F. stage for highest signal level. If the signal is interfered with by radiation of another receiver, the R.F. stage may be detuned until receiver beats with the other receiver, and brings in clear signals. The audio gain is, of course, adjusted to your own requirements.

(Continued on page 642)

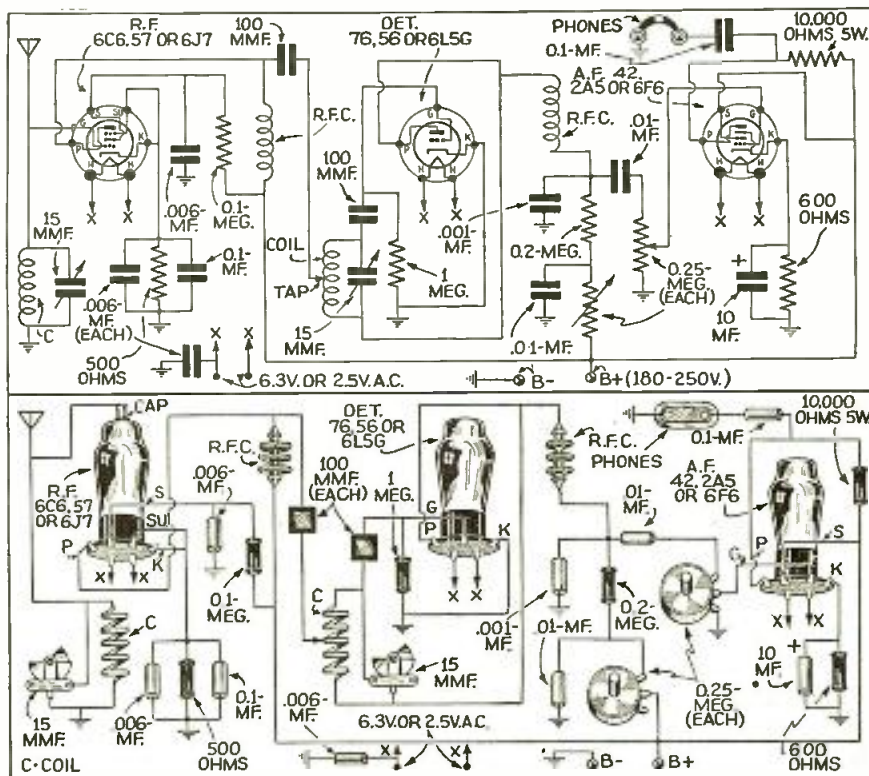

The hook-up for the 5-meter receiver is easy to follow.

# ALL-WAVE SUPER-SIX

This 6-tube battery-operated superhet. receiver will undoubtedly appeal to many readers. The cost of building the set is nominal. "A" supply may be 4 dry cells, air-cell or storage battery.

John Mattern

● IT SEEMS that many small battery sets have been designed, but one with high selectivity, high sensitivity, effective A.V.C., and capable of high fidelity reception is rather uncommon. To obtain these results with 6 tubes, every tube had to be made to work at its maximum gain. Every frequency to be amplified was worked to the limit with the result that the receiver's own noise level is its sensitivity limit. As far as the range of the receiver is concerned, the 1C6 was not designed to operate at 9 meters. However, with careful construction it was possible to extend the range of the tube considerably beyond that given by the manufacturer. It was found helpful to slot the bases of both the tubes in the high frequency circuits and the tube bases in which the coils were mounted.

The voltage on the filaments of the tubes should always be adjusted with a voltmeter before using as the cells recuperate on resting.

### Grid Leads Shielded

The leads to the grid of the 1B4 tube and the 250,000 ohm vol. control must be shielded to prevent audio howl. Also the plate lead of the 33 must be shielded. This may be done by wrapping the lead with some fine enameled wire and grounding it. Tube shields were not necessary on the original set but may be found necessary. A switch (not included in the set) must be used to cut off the A as the B current drains through the 50,000 ohm sensitivity control. This switch was mounted with the filament rheostat and voltmeter (may be included in the rheostat). The dial used was a small airplane dial like those in the TRF sets; nevertheless, it proved sufficient even on the 10 meter band. An aluminum shield between the Ant. and R.F. coils was needed on the low frequency band. It was not fastened down as it was removed for short-wave operation. The piece of aluminum was "L" shaped so it could be rested

without fastening. As the range extends to almost 8 meters the use of the trimmers on the tuning condensers for permanent alignment on the broadcast band was out of the question. This leaves the builder with two alternatives: one, to employ separate trimmers attached to the coils; the other to realign the receiver on band-switching. This is not as difficult as it may seem for once found, the number of turns of the trimmer screw may be recorded.

### Design Is Result of Many Experiments

Here is a caution to any ambitious builder who may attempt to change the circuit for his own purposes. This receiver is the result of experimentation with many 2-volt tube circuits. The by-pass condensers were made large by necessity and smaller ones should not replace them. The resistor values were a compromise between high gain and stability and should be strictly adhered to. For those who may not care to operate the

Diagrams in both schematic and picture form are given below.

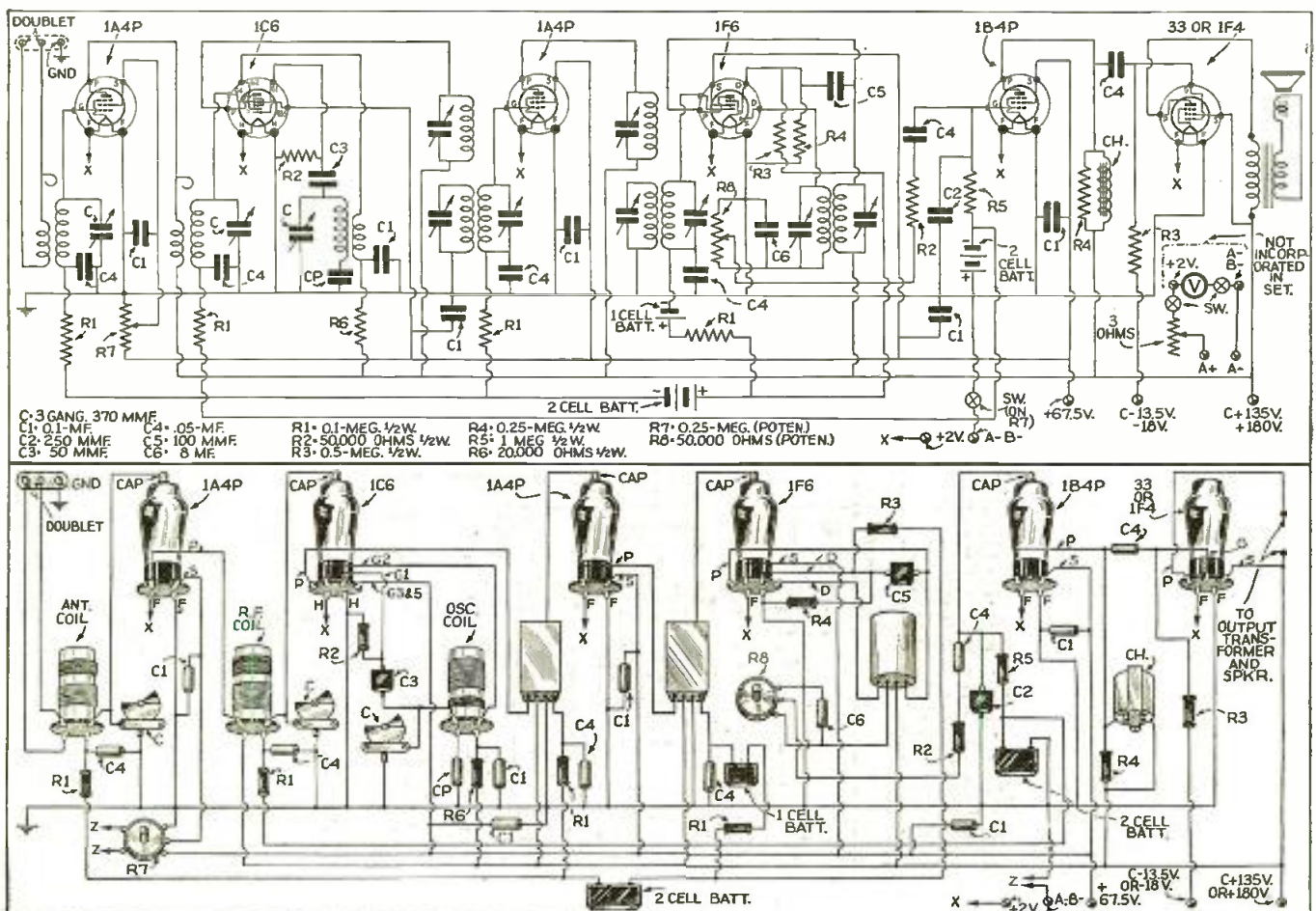

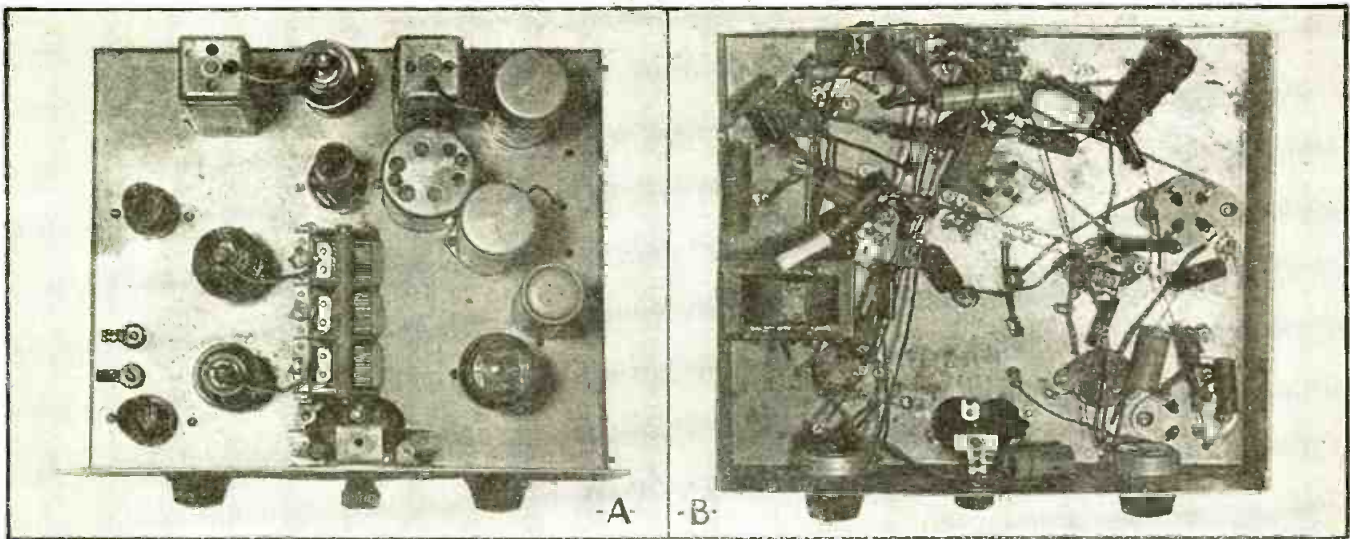

Top and bottom views of the All-Wave Superhet. It operates with a 2 volt "A" battery. Plate supply may be from batteries or a power-pack.

set on the 10 meter band, the 1C6 may be included in the A.V.C. system. This results in *pulling* on 10 meters.

Now a word about the I.F. coils: The coils used in the set were not made by the listed manufacturer. They are not available to the set builder. Nevertheless, equally good coils can be purchased. If possible get three pie-wound triple tuned coils as they are more efficient, giving results approximating iron core coil gain, but with much greater selectivity.

In the first audio stage the plate choke may be an audio transformer. The primary and secondary should be connected so as to form a single winding, the ends serving as the connections to the choke.

#### Choice of Tubes

In the parts list only the regular tubes are listed. The "G" series may be used for all but the 33. As a matter of fact in the original a combination was employed. There is a choice between output tubes. The 33 with a filament drain of .26 amp. and a plate drain of 22 mils at 135 volts or 27 mils at 180 volts may be replaced with a 1F4 with a filament drain of .12 amp. and a plate current of 10.6 mils. The latter gives an output of only .34 watt as compared to 1.4 watts possible output for the 33.

The long-wave coils excepting the osc. coil were not mounted in the tube bases, as the soldering lugs are strong enough to enable the elimination of the dielectric by attaching the plug-in prongs directly to the lugs. The builder may suit himself as to whether he uses tube bases or not.

The padding condenser for the low frequency band should be a .0005 mf. book type adjustable condenser. This is preferable to a fixed condenser and is positively necessary, unless a test oscillator is used to align the receiver's I.F. at exactly 456 k.c. The intermediate band required a .005 mf. paddler. As the coils were from

an RCA all-wave super it would be best to get the exact value recommended by the maker of the coil you purchase. No paddler is needed on the 8-25 meter band. The paddlers are mounted with the coils in the tube bases.

The pencil cells for biasing should be soldered together at one end and taped; then with heavy hook-up wire soldered as one would a resistor. The position of the A.V.C. biasing cells is important. If they are not placed so that the pair and single cell have their positive terminals at the same potential the IF6 may be getting a bias of 4.5 volts instead of 1.5 as recommended by the maker.

#### Alignment of Set

The alignment of the set may be accomplished without the use of a signal generator source. In any event turn up the audio gain. The A.V.C. will not operate on weak signals. Then either align the I.F. channel by the generator note or the tube hiss. Begin at the end and work toward the front. When the I.F. has been adjusted place the broadcast coils in place. Turn the sensitivity control (R7) up and without the use of an aerial tune in a strong signal at 1500 k.c. Then adjust the oscillator trimmer until the station matches the dial calibration. The trimmers across the Ant. and R.F. coils are then to be adjusted for greatest

signal strength. The grid lead to the 1C6 should then be removed and connected to the 1B4 with a short piece of thin wire. The 1B4 will then act as a power detector and you may then tune the set as a T.R.F. Tune the set to a signal at approximately 600 k.c. Leave the tuner at the same spot and place the lead back on the 1C6 grid so that the set functions as a superhet, again. Then adjust the oscillator paddler until the same station is received. The process can be repeated for more accurate alignment.

An aerial will be necessary when the set is operated as a TRF. In some locations a short antenna may be necessary to receive the first signal. Short-wave alignment requires the use of an aerial. The Ant. and R.F. trimmers should be adjusted for the greatest noise. If they do not peak try adjusting the oscillator trimmer. A warning—do not tamper with the factory setting of the I.F. coils, especially if you intend to align the receiver without a signal source.

#### Parts List

##### AEROVOX (Condensers)

- 1—8 mf. electrolytic —C6
- 6—.1 mf. paper —C1
- 6—.05 mf. paper —C4
- 2—.00025 mf. mica —C2
- 1—.0001 mf. mica —C5
- 1—.00005 mf. mica —C3

##### I.R.C. (Resistors)

- 1—1 meg. ½ w. —R5
- 1—50,000 ohm potentiometer
- 2—250,000 ohms ¼ w. —R4
- 4—100,000 ohms ½ w. —R1
- 2—50,000 ohms ½ w. —R2
- 1—20,000 ohms ½ w. —R6
- 1—250,000 ohm potentiometer with switch —R7
- 1—50,000 ohm potentiometer with switch —R8

##### HAMMARLUND

- 1—type "T" 465 K.C. I.F. transformer (has 450 to 470 K.C. range)
- 2—XP 53 coil forms

##### MEISSNER

- 2—sets of Ant. and R.F. coils (550-1600 k.c. and 16-51 meters)
- 2—oscillator coils to match Ant. and R.F. coils, 456 k.c.
- 1—3-gang .00037 mf. tuning condenser

##### RCA (Tubes)

- 1—1B4
- 2—1A4
- 1—1F6
- 1—33 or 1F4
- 1—1C6

(Continued on page 646)

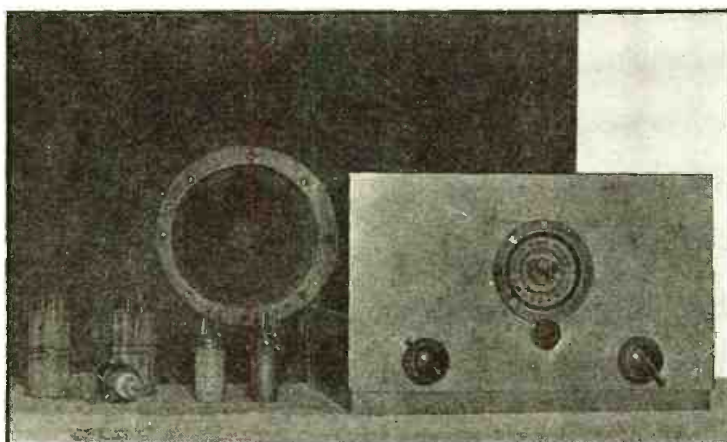

Front view of the 6-tube receiver, together with the large baffle and dynamic speaker.

# Relay Made From Ford Coil

Edwin Gearhart

● THE mechanical problems involved in the construction of a sensitive relay are so difficult that they are almost beyond the skill and equipment of the average experimenter. The problem is to get many turns of fine wire wound around an iron core so that a few mils of current furnish an electro-magnetic field capable of operating a small switch. The secondary of an old Ford

Shallow small drill marks in the ends of the bolts are the actual bearings. These supports are mounted on the two of the four bolts on the top of the coil near the narrow edge. Place a large Fahnestock clip under one of the supports to furnish a means of contact to the switch arm. The armature or switch arm is made from a piece of brass 5 inches long and 1/4 inch wide. Solder a

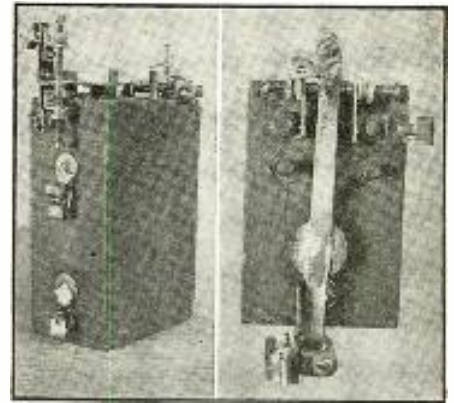

Two views of the finished relay made from a Ford spark coil.

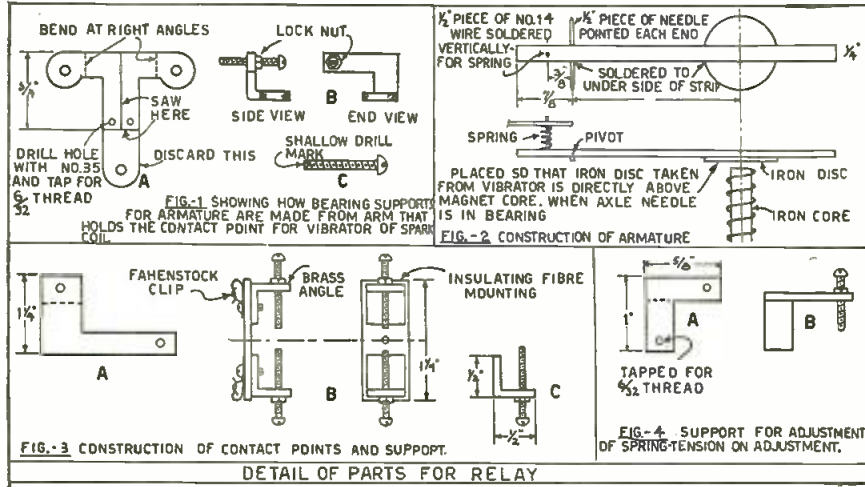

The drawings above show various details of construction in making the relay.

spark coil is used as the electromagnet for the relay described.

Remove all parts from the top of the coil. The bearings that support the switch arm are made from the long brass piece removed from the coil. Saw and bend as shown in figure 1 A and B. Be sure to bend them so that you have a pair of supports. Drill and tap as shown in the diagram.

needle axle which is about 1/2 inch long to a vertical piece of wire for spring holder, and solder or rivet the iron vibrator disc to the piece of brass as shown in figure 2.

Cut the fiber 1 1/4" x 1/2" and drill holes as shown in figure 3 B. Make the brass angles that support the contact screws as in C. Assemble as shown in figure 3 B and cut and bend the support as in A. Mount

this assembly so that as the armature moves up and down it makes a good contact with each of the bolts. This whole unit is mounted on the screw which held the tension spring for the Ford coil.

The next part is the spring and support which lifts the armature away from the magnet as soon as the current stops. Cut the metal as shown in figure 4 A and bend it as in B. Mount this assembly so that the bolt is directly over the short vertical wire on the armature. The spring is taken from an old tire valve and is placed between the bolt and the wire on the armature. Solder the two large Fahnestock clips to the brass contacts on the side of the spark coil.

USES. When properly adjusted this relay will operate upon about four mils (ma.) of current, and can be used to control up to about 100 watts. It has been used in photo-electric circuits, experimental radio controlled appliances, and burglar and fire-alarm units with results equal to those obtained from expensive relays.

MATERIALS. Ford spark coil, 2 Fahnestock clips (small), 3 Fahnestock clips (large), 3 bolts 6/32 5/8" long, 3 bolts 6/32 1/4" long, 2 bolts 6/32 1 1/4" long, 1 piece of brass 1"x1/4", 5 6/32 nuts, 1 piece brass 3 1/2" long, (Continued on page 643)

# A Better Code-Practice Oscillator

● THE audio oscillator described in this article answers the requirements of radio fans interested in learning the code, in that it is very simple to construct, gives an excellent tone, and plenty of volume. The only parts needed in its construction are an audio transformer, a tube socket, the base from an old tube, one resistor and some wire. The dots and dashes are heard in the loud-speaker whenever you operate the key.

As the wiring diagram figure one shows, this device simply connects an audio transformer in the plate and grid circuits of the first audio stage of your radio receiver, thereby converting the receiver into an audio oscillator which is keyed in the cathode circuit of this tube.

The purpose of the resistor R in figure one is simply to give the desired tone to the oscillator, and can be chosen to suit the circuit of your radio and the audio trans-

former you use, to give the tone or frequency of oscillation you want. The value of R should be in the range from 500 to 10,000 ohms, depending on your radio and transformer, it being possible that you will

not need any resistor in this part of the circuit.

The diagram is for a radio receiver using a five prong tube, such as a type-27 as the first audio (Continued on page 643)

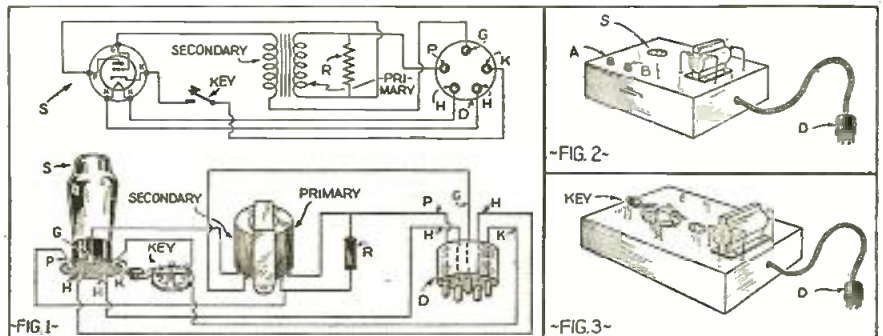
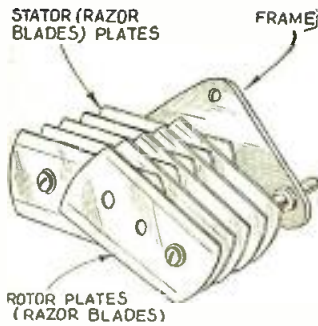

Diagram of novel code-practice oscillator—it plugs into your receiver.

# Short Wave Kinks

Each month the Editor will award a 2 year subscription for the best short-wave kink submitted. All other kinks published will be awarded eight months' subscription to **SHORT WAVE & TELEVISION**. Look over these kinks; they will give you some idea of what is wanted. Send a typewritten or ink description, with sketch, of your favorite to the "Kink" Editor.



## RAZOR BLADE USE

1st Prize Winner

One of the cleverest home-made variable condensers we have ever seen is shown in the illustration. As can be seen it is made from a set of old razor blades which serve as the rotor and stator blades for the condenser. The stator blades are permanently fixed in one position while the rotor assembly is, of course, movable. Condensers of any capacity can be made by increasing or decreasing the number of razor blades used. This kink has double utility because it also solves the problem of what to do with old razor blades.—*Armando deho Cruz.*

## MIKE STAND



A French handset can be adopted for desk use with practically no trouble and, what is more, at no expense. A short desk stand may be made by unscrewing the mike head from the arm and reversing the collar screwed on the rear of the mike head. In this position, the microphone may be stood on a desk, as shown. A taller stand can be made by fastening the mike and collar on top of a tall cardboard tube, and it may be given a professional appearance by painting the tube with telephone black. The handle of the handset may be sawed in half so that the microphone stand can be set on top of an ordinary desk-stand.—*Chas. Baker.*

## MEASURING TRANSFORMERS

When winding your own transformers, it is frequently impossible to accurately gauge the voltage by counting the number of turns on a winding. An accurate way of measuring a new transformer's voltage is by comparing it with another transformer having the desired volt-

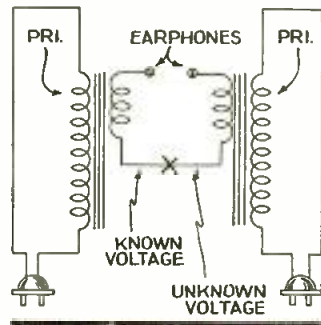

age. This is done by connecting the two transformer windings together, as shown in the diagram, and connecting a pair of earphones in series. If the voltages developed across the windings are not equal, a hum will be heard in the headphones. Add or remove turns from the transformer under construction until no hum is heard in the phones. When this occurs, it is an indication that the voltage of the new transformer is the same as that of the standard transformer. When connecting the transformers together, make sure that the windings connected together are not opposing each other in phase, because if they are, no sound will be heard in the headphones, even when the voltages are different.—*Engelbert Barstsch.*

## COIL WINDER

Here is a gadget which should appeal to the man who winds his own. It is a home-made coil winder for simplifying the task. A block is drilled for ordinary plug-in coils. Several sets of holes may be drilled so that 4, 5 and 6 prong coils may be placed in the winder. To operate the device, simply start the wire on the coil form and turn the crank with one hand while guiding the wire with the other hand.—*Ernest Long.*

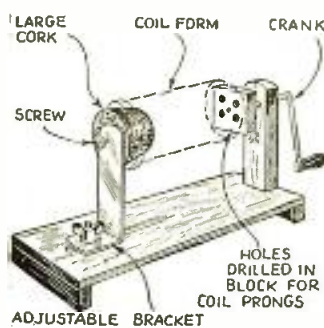

## NOVEL QSL MOUNT

A very novel way of mounting QSL cards is illustrated. This scheme has the added advantage of being educational. As the sketch shows, QSL cards are mounted along the side of the map, and a string or piece of paper is then placed on the city in which that particular station is located. In this way, the exact location of each station is shown in graphic fashion.—*J. S. Shino.*

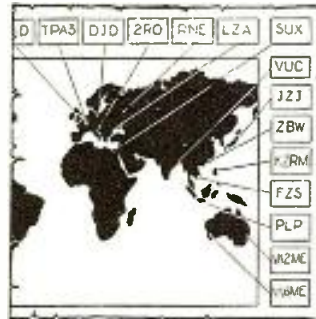

## A SHIELDED PLUG

A new use for defective metal tubes is to remove the metal jacket from the tube and make use of it as a shielded cable connector (see sketch). This particular assembly is especially well adapted for use with shielded cable, as the metal shield serves to thoroughly shield the leads at the end of the cable.—*H. Campoy.*

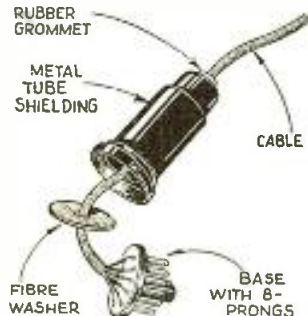

## ANTENNA TUNING

A simple method of quickly changing the tuning system on a ham transmitter is illustrated. By throwing the D.P.D.T. switch parallel or series tuning of Zepp feeders can be obtained, using only a coil condenser and a switch. The switch should have ceramic insulation to minimize losses at high frequencies.—*Alfred Soboltski.*

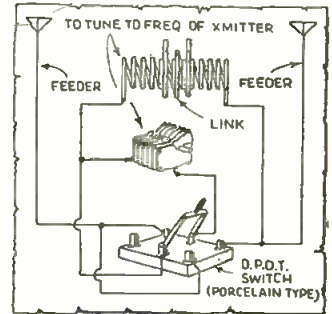

## POWER SUPPLY

A novel rectifier unit for operation on 110 volts, is sketched. The hookup is perfectly straightforward except in one respect. Instead of using a resistor in

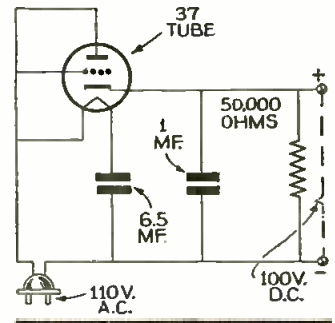

series with the 37's heater to reduce the voltage a paper condenser is placed in series. By picking a condenser of suitable size, the proper voltage drop is obtained. As all condensers have a definite resistance to alternating current, the voltage drop depends on the capacity of the condenser. For use with a 6.3 volt tube, with a filament current .3 amp, a 6½ mf. condenser is satisfactory.—*Theodore Stearn.*

## EMERGENCY GROMMET

Probably every experimenter, at one time or another, has found that he needed a rubber grommet for insulating a chassis hole, and all too frequently he has found that he didn't have one. If ever in need of an emergency grommet, it can be made from a piece of ordinary spaghetti. The spaghetti should be split lengthwise and cut to the same length as the circumference of the hole, then slipped around the hole on the chassis.—*George Norman.*

# The Listener Asks

Questions asked by not-so-technically inclined listeners are answered in this new department.

## NOISY RECEPTION

**Q.** My all-wave receiver makes crackling noises intermittently. It sometimes behaves perfectly for a day or so, but eventually the noise returns. What is the possible cause of this and what can I do to remedy it?

**A.** The cause of noisy reception, either on short or broadcast waves, is one of the most difficult things to diagnose. In general, the sources of noises can be classified as follows:

First—those originating in the set itself. Defective fixed condensers or resistors are a frequent cause of annoyance. Corrosion of soldered joints and oxidation of tube prongs and tube shields also frequently cause noises. Dust collecting in various parts of the receiver chassis can cause a great deal of trouble, both in the way of noises and also in the matter of reducing the set's sensitivity.

Defective condensers or resistors can be only located by means of careful checking one by one. Corrosion of soldered joints can be investigated by gentle pulling on the wires close to the point where they are soldered. It should be noted, however, that this is not an infallible test, sometimes the joint may be mechanically secured while electrically bad. Oxidation of tube prongs and tube filters is a relatively simple matter to check and remedy; simply remove each tube and shield from the set and clean the tube prongs and tube shields with a cloth and replace in the set. In the act of replacing move the tube in and out of the socket several times to wipe the contacts clean.

The same procedure should be followed when cleaning the shields. This simple procedure will frequently perform wonders when the receiver has been used for several months or more.

Dust is one of the greatest enemies of a radio receiver, and ideally the set should

have a dust cover placed over the chassis at the time of installation to protect it. If this has not been done it is a good idea to thoroughly clean the top of the chassis at least once every six months. Pay particular attention to the removal of dust from tubes and tube sockets and from between the movable plates of the main tuning condenser. The easiest way to clean the tuning condenser is by inserting ordinary pipe-cleaners between the plates of the condenser section as shown in the sketch.

Noises originating outside the receiver can be caused by poor joints in the aerial or the ground leads, or by the aerial scraping against another object. Dirt and grime which sometimes collect on the aerial insulators can cause noisy reception also, and it is a good thing to clean the insulators with a little benzine.

An old but effective means of determining whether noise is originating in the receiver or from the aerial system is to tie together the aerial and ground posts on the receiver and turn up the set's volume control. If there is no noise when this is done, it is safe to assume that the noise is originating outside the receiver. If, however, the noise continues, then the trouble is more than likely in the receiver.

## REPLACING TUBES

**Q.** Numerous inquiries are received concerning the advisability of modernizing commercial receivers by replacing the old type tubes with some of the new and improved types now available.

**A.** In general it is not practical to replace old type tubes with the newer type, unless considerable changes are made in the circuit of the receiver. And in some cases, even though changes are made, the final result may be poorer reception than with the old tubes.

The reason for this is that the newer tubes require specially engineered circuits and parts to perform satisfactorily, and unless a radical change is made involving the replacement of a considerable number of parts in the receiver, its performance will not be satisfactory.

A commercial receiver is generally built around the tubes it uses, the tubes are not thrown in as an after thought.

In a few cases it is possible to replace older tubes with the newer ones, either with no changes or minor changes, and new tubes will give results as good as the old, and in some cases slightly better, but to realize maximum benefits from any type tube it is necessary to design the circuit around the tube.

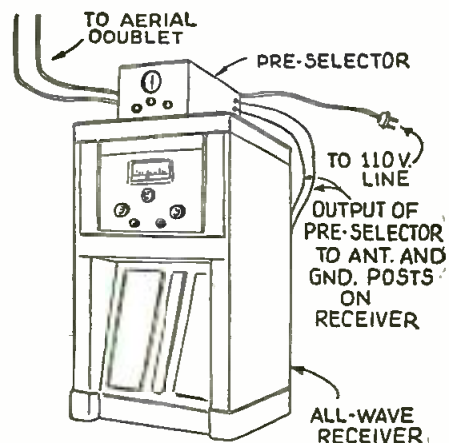

Connecting a pre-selector to an all-wave set

## IMPROVING ALL-WAVE SETS

**Q.** I have had an all-wave receiver for about a year. While it gives satisfactory reception on the broadcast band, I find that short-wave stations are not very well heard; the signals are weak and mixed with a continuous hissing sound. I have a special all-wave aerial system but this does not seem to help. What can you suggest to improve short-wave reception?

**A.** Your trouble is a fairly common one among owners of all-wave receivers. A good many of these receivers are not capable of giving very good performance on short-waves because of the frequent necessity of the manufacturer adopting a compromise design between good broadcast reception and good short-wave reception. The best remedy for this condition is to add a pre-selector unit to your receiver.

This unit is used only when listening to the short-waves. Commercially available pre-selectors contain from 2 to 3 tubes and may be plugged into the power line. The aerial system is connected to the input of the pre-selector while aerial terminal of the receiver goes to the output of the pre-selector.

When tuning on the short-waves it is necessary to tune both the all-wave receiver and the pre-selector. The pre-selector acts as an additional amplifier for the short-waves and will give greatly improved performance with virtually any all-wave receiver.

The method of connecting a pre-selector is sketched above.

## SIGNALS FADE

**Q.** I have recently become interested in short waves and have purchased a fairly good short-wave receiver, but I am having  
(Continued on page 649)

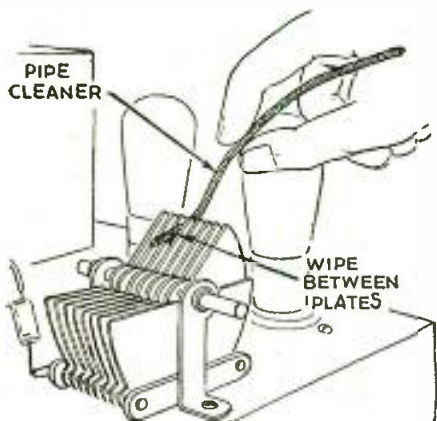

Removing dust from tuning condensers

# LATEST in Short - Wave APPARATUS

## New Television Tubes

● THE more critical requirements of television reception are being met by two new cathode-ray tubes recently developed and now available on the market. The smaller tube has a 5-inch diameter screen and a maximum third anode voltage rating of 3000. The large tube has a 6000-volt rating and a twelve-inch diameter screen.

Both of these tubes employ a unique design which prevents de-focusing of the spot when the video signal modulates the tube. This has heretofore been one of the difficulties with television reception, because when the cathode-ray tube was adjusted to

give a sharp line at a certain value of signal, it blurred at other signal values. With these new television reception tubes a sharp focus is maintained at all values of applied video signal, giving a clearer-cut television picture than it has been possible to obtain with any of the tubes available until now.

The standard screen provides a pleasing green light. However, tubes are available on special order from this manufacturer with a white screen giving a black-and-white picture.



One of the new 12" cathode ray television tubes. (No. 686)

Both tubes mentioned employ electrostatic focusing and deflection. Electrostatic focusing is believed by the engineers of the company making these tubes, to be more  
(Continued on page 641)

## Automatic Radio Key



A new automatic transmitting key. (No. 687)

● THE demand for an automatic key of greater speed range than the original key primarily designed for amateur use, necessitated the production of an improved key applicable to all operating speeds.

In the designing of this improved key, chief consideration was given to simplicity, accuracy, compactness, elimination of noise and ease of operation.

Excepting a simple buzzer or oscillator, the improved automatic key is a self-contained unit, ready to plug in on the A.C. circuit and go to work.

For the beginner, code symbols are quickly memorized through practice in punching code in tape. After a working knowledge of the code has been acquired, complete calls or messages can be punched out, a buzzer or oscillator connected to the key and these tapes run through the sending mechanism, beginning at such speed as may be correctly and instantly interpreted, increasing the speed as the proficiency increases. Listening to this even sending, the ear becomes trained to the sound of correct code and the hand, in key practice, rapidly co-ordinates with the accuracy of the ear.

The automatic radio key is simple and  
(Continued on page 641)

## New 833 Tube

● THIS new RCA tube known as the 833, is of the high-mu type and is suitable for use as a radio frequency amplifier, oscillator and class B modulator. As a result of its construction, the 833 provides high plate efficiency at moderate voltages. For example, it is capable of giving a carrier output of 635 watts with 2500 volts on the plate, and with this carrier output it can be modulated one hundred per cent.



The 833 RCA transmitting tube. (No. 688)

In such service as experimental ultra-high frequency transmitters, the 833 provides excellent efficiency. It can be operated under conditions of maximum input rating at frequencies up to 30 megacycles (10 meters); for reduced inputs its operating range is then extended to 100 megacycles (3 meters). As a result of its unusually rigid construction, the 833 provides exceptional efficiency at high frequencies. For example it can be operated in class C telegraph service with maximum input of 1250 watts at frequencies as high as 30 mc., and with reduced input up to frequencies of 100 mc. For greater power  
(Continued on page 640)

## U.S.W. Police Phone

● AN ultra high frequency police radio transmitter of advanced design for use in the band between 30 (10 meters) and 42 (7.1 meters) megacycles is illustrated. The power output is a full 25 watts (unmodulated) and 38 watts during modulation. This transmitter, designed by Bell Telephone Laboratories, is the first to appear incorporating the new *signal boosting* amplifier circuit, which permits operation at an unusually high percentage of modulation without risk of exceeding the predetermined maximum on peaks.

The audio frequency amplifier consists of four stages, with a total gain of approximately 100db and an audio output conservatively rated at 25 watts. The automatic gain device incorporated in this amplifier maintains the modulation at a high percentage almost independent of the speech level introduced at the microphone. Since radio coverage depends upon the average per-  
(Continued on page 640)



Latest ultra-high-frequency police transmitter for use in the 30-42 megacycle band. (No. 689)

Names and addresses of manufacturers of apparatus furnished upon receipt of postcard request; mention No. of article.

# New System of Inductive Tuning and How It Works

W. E. Schrage

● "It was customary at the beginning of wireless telegraphy—some 30 years back—to operate with a variable inductance, and sometimes to use in addition to it a fixed capacity. As oldtimers will remember, the results obtained with this old fashioned equipment were not always as bad as one might expect."

These were, roughly, the introductory words preceding a lecture by Lieut. Paul Ware, one of America's best known radio engineers, given recently before the Radio Club of America. His lecture dealt with a new inductive tuning system which, in its very principle, makes use of a variable in-

ductance—or more precisely described, a rejuvenated form of the antique slider coil—used by broadcast listeners in the days of crystal detector receivers. And despite this "ancient history" background he believes earnestly that his modified slider coil will cause great changes in the design of modern all-wave receivers.

Probably nobody but this oldtimer of radio fame, would have had the power to bring together the cream of America's radio engineers in a lecture hall at Columbia University. All the well-known objections against variable inductances, such as insecure contact, etc., melted away like snow in the spring sun, as Mr. Ware delivered his lecture. But more than this, Mr. Ware informed the author after the demonstration, that he believes a number of radio companies will equip their sets in the near future with this new tuning system.

How far this will be realized, no one can tell now, but his method of tuning certainly provides great possibilities for covering broad frequency bands, all without any need of switching and obtaining split-hair tuning without the use of bandspread gadgets or AFC circuits. These advantages

History often repeats itself. Here is the latest tuning device which employs adjustable inductances, similar to the old slider type tuning coils. This variable inductance method of tuning bids fair to find its way into the short-wave field.

probably will cause designers of all-wave receivers (especially of sets equipped with "electric tuning") at least, to experiment with the new variable inductance tuning method.

The improvements claimed by Mr. Ware certainly present an urgent challenge to radio designers to consider this "old fashioned" method of tuning for practical application today. Nevertheless every time the idea of using variable contacts on coils comes up, many a radio engineer is inclined to discard the idea at once, and try to achieve the effect desired with a variable condenser.

The ultimate success of Mr. Ware's inductive tuning device lies of course in the ingeniously designed method of producing good contact. But before going deeper into the matter of contact let us first look at Fig. 1, which represents the fundamental circuit. The variable coil (Lv) is connected with the end-coil (Le). The padding condenser (Pd) is used to align the various tuning units required if the set is equipped with a number of R.F. stages.

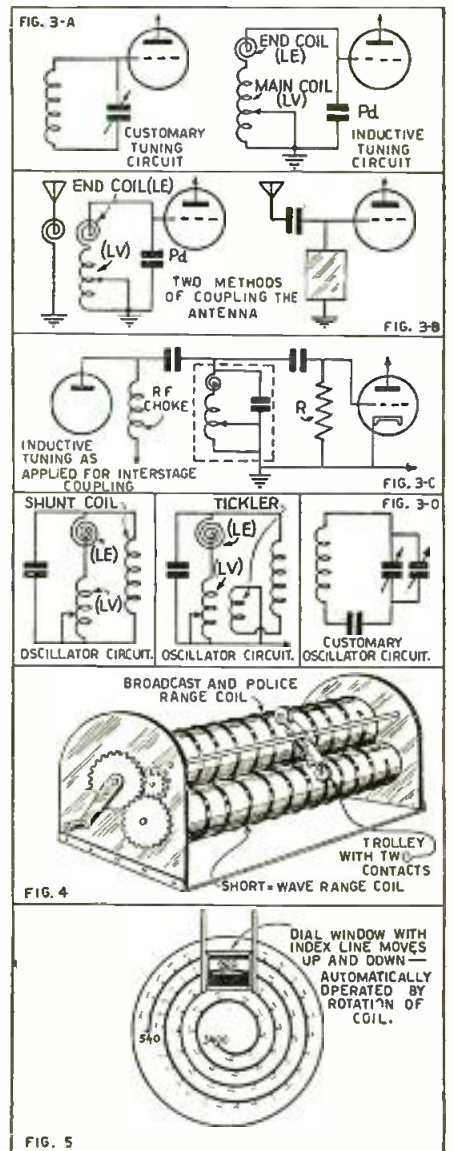

A few of the fundamental circuits of the new tuning scheme involving variable inductances instead of the familiar condensers are given above. Fig. 4 shows a dual-band coil arrangement and Fig. 5 a suggested form of spiral dial design.

And now some explanations as to the purpose of the end-coil (Le): The purpose of this end-coil is to prevent the so-called "natural frequency"—of the short-circuited part of the coil of Fig. 1B and C—from becoming as large as that of the rest of the coil (at certain positions of contact CT). In other words, the end-coil is made large enough to prevent the short-circuited part of (Lv) from absorbing energy from the active part of the main coil. Such would

(Continued on page 642)

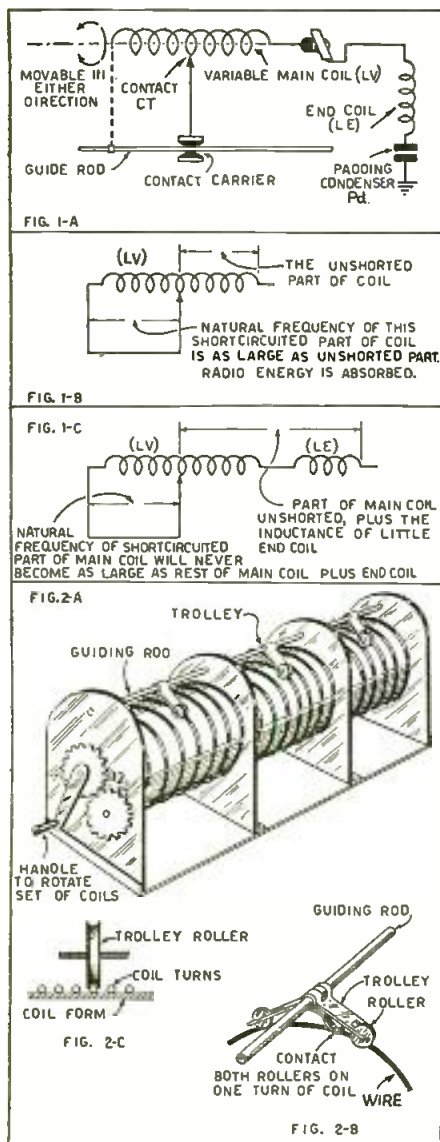

Back to tuning coils with Sliders? Well here they are—1938 model—and they're reputed to be particularly useful for short-wave tuning.



# Alignment Procedure for the All-Wave Superhet

F. L. Sprayberry

We asked Mr. Sprayberry to prepare this special article explaining in clear style how to use an oscillator to line up the I.F. stages in all-wave superhets.

● With the prevalent complication of modern all-wave receivers, it seems difficult to prescribe a "routine" procedure for their alignment. However, there are only two pieces of necessary test equipment, the *signal generator* and the *output indicator*, the connections of which vary with the equipment as well as the circuit design.

The I.F. amplifier always comes first in the sequence of adjustments, so it would be well to discuss application of these two pieces of equipment for all conventional circuits.

## First Step

We first attach the output indicator to some point in the I.F., second detector, audio or speaker circuits so that its deflection or indication will be representative of the relative signal strength being fed into the receiver. The diagrams herewith have been prepared with a view toward assisting in making the proper connection. From this information you should be able to make a suitable connection with any equipment at hand, falling within the requirements set forth.

Your preference, of course, depends on the apparatus you have available and the degree to which you can select a range most suitable to the circuit operation. In many cases, it may be added, the tuning indicator already on the receiver may be used as an output indicator without any additional equipment. Its use will, of course, mean that the receiver uses A.V.C. In all cases of this kind and regardless of the method of connection of the indicators, the A.F.C. circuits, if used, must be *grounded out*. Further, it will be necessary to disconnect A.V.C. action if the indicator is connected in the audio or speaker sections.

This may be done in practically every case by *grounding* the A.V.C. supply lead immediately beyond the first resistance filter, for controlled tubes using cathode resistors (see Fig. 1), or grounding through a 3 volt dry cell battery (negative at A.V.C. line—positive to ground) for controlled tubes with grounded cathodes. Where there are a number of A.V.C. feeders for different A.V.C. voltage values, each must be grounded separately, with the precaution noted above accounted for.

Invariably there will be a switch provided for shorting out the Automatic Frequency Control if such is used on the receiver. No attention need be given to either Q (*noise squelching*) circuits or volume-expander circuits, as they will really be an aid if in proper working condition. The Q circuits will insure proper signal level,

while the volume-expanders will spread the indication over more range for a given ratio of volume increase or decrease, thus permitting a more accurate adjustment.

When correctly applied the *indicator* will be suitable for all alignment work and may be left in place until the job is finished.

## The Signal-Generator Connection

In most cases the alignment can be made by connecting the signal-generator to the I.F. input in such a way that it may remain for all I.F. adjustments. However, in special cases the original alignment may be so far off that it would be quicker to apply the signal to the input of one stage at a time. However, we will begin at the input of the I.F.

The first tuned I.F. coil is invariably in the first detector plate circuit which is isolated from the control grid circuit by a screen or by neutralization. This is an advantage in alignment as it is advisable to make a connection which will make the minimum possible change in the circuit from actual operating conditions.

For triodes, tetrodes and pentodes as first detectors the signal is fed into the *control grid*, while for converters and mixers there are other signal grids available in addition. Any of them may be used. Connections to screen or suppressor, of course, will *not* be effective as a rule.

Of the choice between the various output circuits or taps of signal generators, where possible use the MED. or LOW values, because: (1) this usually allows for control of the output signal and (2) these taps have condensers in series with the leads which prevent interference with the D.C. bias on the signal grid to which the generator is attached. If this results in insufficient signal strength for the proper adjustments use the HIGH tap with a series condenser, .001 to .0001 mf.

It is best practice with converter tubes (2A7, 6A7, 6A8) or mixer types (6L7) to feed the signal into the top cap control grid by removing the grid cap lead attached to the R.F. output and attach the signal generator lead to that. Ground the grounded signal generator lead to the receiver chassis.

## How to Stop Set's H.F. Oscillator

It is desirable in some cases to prevent the set's H.F. oscillator from oscillating, which may be done in the converter by *shorting* the plate or grid coils, and in the mixer by removing the oscillator tube as it is a separate tube when a mixer tube is (Continued on page 637)

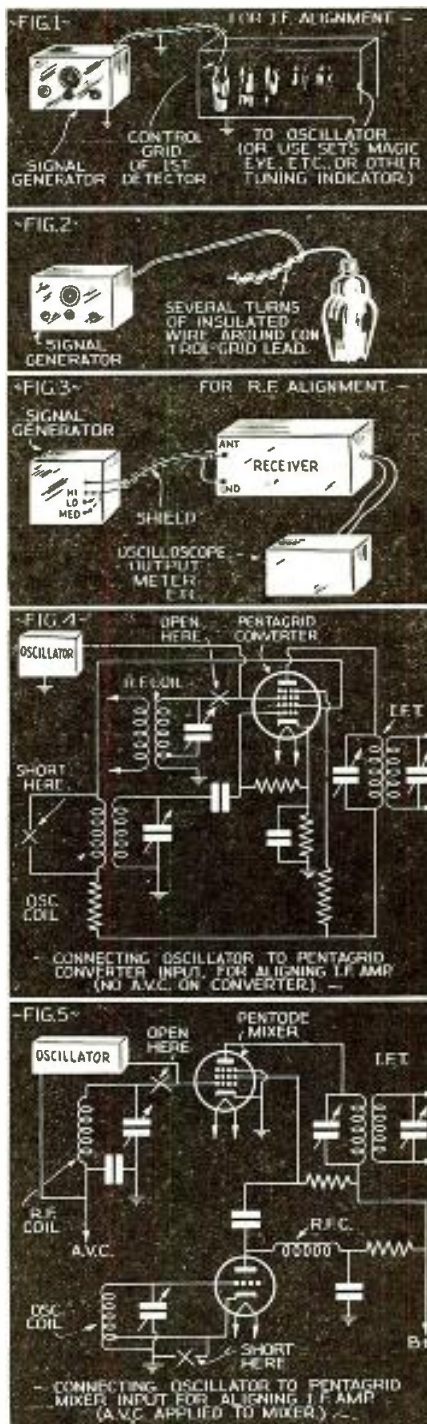

Several ways in which an oscillator may be connected to an all-wave superhet for checking successive stages.

# Let's Listen In



YT7KP—A rare QSL from a Jugo-Slavian amateur, with blue card and letters.



CN8AJ—This QSL for the past 40 meter "Special" broadcast. This French Moroccan amateur sends a handsome QSL, blue letters on light blue background.

## With

*Joe Miller*

### Winner of the 30th S.W. Scout Trophy

● THIS past month of December has had more than its share of "ups and downs" in regards to best DX conditions, and, judging from our readers' reports and opinions, was more bad than good in the way of ideal reception.

The days that were good were very good, and the "other" days, much in the majority, were—well—let's skip it! We did note that on weekends, whenever the day was warmer than average and also sunny, the tuning conditions were unusually good, though DX from certain continents only was heard in this fashion.

As the seasons move in and out, best conditions for certain parts of the world become effective, and these "peaks" are so consistent, every year at the same date, that, judging from our observations of several years standing, we can predict, with little fear of inaccuracy, the months, and even weeks of the year, when some particular continents should be received best.

Looking ahead to February, three weeks away from the date of this writing, we feel certain that reception from Asia and Africa will be very good, with the fact to be mentioned that February is about the quietest month of the year, on the short waves.

Last February we were able to hear CT2AJ, 4.002 mc., Azores Islands, best near 6-7 p.m., Sats., CR6AA, 9.666 mc., Angola, Portuguese West Africa, best around 3:30-4:30 p.m., many good Asiatic S-W "B.C." and phone catches in early a.m.'s, and occasionally throughout the month. South African amateur DX on 20 meter phone between 11:30 p.m. and 1 a.m.

During the latter half of February, 20 meters "awakened," and hams in Europe and Africa, including some of the more distant countries in Europe, were "coming through" between 3-7 p.m., though only on good DX days. It is wise to be on the lookout also for Asiatic 20 meter phone hams in early mornings.

Look for the aforementioned DX, and for good reception in general from most of the globe this month, when conditions will be on the up-swing, mostly noticeable on the 20 meter band.

On the 20 meter band, things will be picking up slowly begin-

ning an improvement in reception which will reach a broad peak during March and April.

Our advice is to look to ones equipment and antennae, with an eye to any possible improvements, in preparation for the coming World-Wide Amateur DX Contest late in March, when amateurs from every corner of the world will be in active competition, mainly on the all-absorbing, and rightly so, 20 meter band. Some unusual DX can be expected during, and after the contest, marking the period of the new year when the amateur begins to take new interest in DXing, due to peak DX conditions for world-wide contacts.

Reception on all bands will be bettered during March and April. Reception during the past month has been mainly on the amateur bands, during the day and evening, our early morning time being very limited.

Now for DX:

#### SOUTH AFRICA

ZRH, on 9.523 mc., at Roberts Heights, has been coming in much better than ZRK, on 9.606 mc., at Klipheuevel, both carrying the same Capetown programs, and very well heard between 11:45 p.m., and 12:45 a.m., ZRH also on 6.007 mc.

ZRK is the station recently reported as ZTJ.

Full data received from the South African Broadcasting Corp. lists 4 stations now in operation. These are ZRK, ZRH, ZRJ, 6.0975 mc., at Maraisburg, and ZRD, 6.15 mc., at Durban. We believe that all four carry the same programs, as do ZRK and ZRH. Schedules in full for these stations are as follows:

ZRK, weekdays except Suns.: 11:45 p.m.-12:45 a.m.; 3:20-7:20 a.m.; 9 a.m.-11:45 a.m. And on 6.0975, using the same call, from 11:45 a.m.-4 p.m. On Suns., ZRK operates from 3:30-4:30 or 4-5 a.m., this varies, and 8-11:40 a.m., on 9.606 mc., and on 6.0975 mc. from 12 noon-3:20 p.m. ZRK uses 5 kw. power. On the 11:45 a.m.-12:45 a.m. schedule ZRK is on Sun. night, not Sat.

ZRH on 9.523 mc., operates from 11:45 p.m.-12:45 a.m. and



SABC—This card is sent for all South African S-W broadcasters. This one is of ZRK. Card yellow, letters green.

5-7:30 a.m., and on 6.007 mc., from 10 a.m.-4 p.m., weekdays, on Sats. till 4:45 p.m. Power also 5 kw. On the 11:45 p.m. schedule, ZRH is not on, Sat. nite, as ZRK.

ZRJ operates 11:45 p.m.-12:45 a.m.; 3:15-7:30 a.m.; 9-11:30 a.m. Sat. schedule as above, with exception of being on from 8:30-11:30 a.m. and off from 11:45 p.m.-12:45 a.m. On Sms., ZRJ operates from either 3:30-4:30 a.m. or 4-5 a.m., and from 8-11:30 a.m. Power 200 watts. This cannot be the old ZTJ, as that station had 5 kw.

Also listed is ZRD, though, with a power of only 10 watts, we doubt if it will ever be heard in this country. ZRD's schedule: 11:45 p.m.-12:45 a.m., ex. Sat. nite, as with all others, and daily from 3:30-7:30 a.m.; 9 a.m.-3:45 p.m. On Sats. ZRD operates till 4 p.m. On Suns., 8-11:30 a.m.; 12 noon to 3:20 pm.

Identification on midnite program with call sign and bugle, other programs identified by call sign; this for all stations.

Address for these stations is the same: South African Broadcasting Corp., P.O. Box 4559, Johannesburg, South Africa. These stations all verify promptly with the attractive QSL pictured in this month's article.

#### ANGOLA

CR6AA, 7.177 mc., at Lobito, was again heard, at 3:50 p.m., with their usual very deep fading, fading out completely, then returning and growing to an R 5-6 signal, this cycle repeated slowly and regularly. This can be considered a rare catch for any DXer, as combing through the mess of terrific QRM on the 40 meter amateur band, in the midst of which CR6AA is located, and being able to log this catch, is no mean accomplishment.

Try for CR6AA in February on both 7.177 mc. and 9.666 mc., the schedule is 2:30-4:30 p.m., Weds. and Sats. Try from 3:30 to 4:30 p.m., this is when CR6AA should peak.

QRA is: P.O. Box 103, Lobito, Angola, Portuguese West Africa.

#### BRITISH HONDURAS

ZIK2, 10.60 mc., at Belize, is now being heard on a regular schedule, on Tues., Thurs., and Sats., from 7:30-7:50 p.m.

This enables many DXers to add this new and heretofore unheard country to be added to their "logs." Broadcasts open with a recording or two, followed by British Official Wireless Press news.

This station is heard fairly well, and is on a channel free of interference from any other station, so it can be easily "spotted." Our only QRA is as above.

#### RADIO MARTINIQUE

Operating on 9.685 mc., although veri says 9.70 mc., this station is very well heard here, and offers many DXers an opportunity to add yet another country to their DX lists.

Schedule is 6:45 p.m.-7:45 p.m., every night, with 200 watts power. Also operate from 11:30 a.m.-12:30 p.m. QSL cards are soon to be ready, now verifying by letter, with the gorgeous French Colonial Stamps on the cover.

Address: Radio Martinique, Boite Postale 136, Fort de France, Martinique.

#### MOROCCAN BROADCAST

CN8AJ, 7.045 mc., Casablanca, French Morocco, has arranged another "Special Broadcast," for Feb. 14-15, at 2-2:30 a.m., E.S.T. Power 150 watts. On the last "Special," the antenna was not designed for 40 meters. CN8AJ should be well heard on this broadcast. He will first be on 20 meter phone at 1 a.m., each day, tuning up the transmitter on 20 meters, 14,090 kc. Address—Rene Crettien, 29 Rue de Villas, Casablanca, French Morocco. All reports with postal reply coupons will be confirmed with beautiful new blue QSL cards. When writing, please thank Rene for his courtesy.



KZRM—The Manila station sends a handsome card, red letters on yellow background.

#### TAHITI

FO8AA, 7.10 mc., at Papeete, is beginning to be well heard on their schedule of Tues. and Fri. nights, 11 p.m.-midnite. However, FO8AA usually "carries on" till about 12:30 a.m.

Programs are typically Hawaiian or Polynesian, and when the station comes in with a good signal, usually near midnite, are very enjoyable, if the code QRM permits reception. Heard FB at 11:50 p.m.

This catch in the South Seas should put in a good signal during February, and we urge all to try for it, as it's sure to be heard, one day or another, and they confirm with an attractive QSL card. Power is 200 watts.

QRA: Radio Club Oceanien, FO8AA, Papeete, Tahiti.

#### U.S.S.R.

ROU, 14.79 mc., Omsk, Siberia, heard phoning RIM, 15.25 mc., Tashkent, Russian Turkestan, both good signals, at 9:30 a.m. These stations no longer verify. RIR, 10.08 mc., at Tiflis, heard at 2:20 a.m. All U.S.S.R. stations when phoning use clear speech, having little fear anyone will understand them.

G. C. Gallagher, W6, reports, RIR at 1 a.m., RKI, 15.04 mc., Moscow, phoning at 11 a.m., RWJ, 12.18 mc., Alma-Ata, frequently broadcasting programs similar to RNE's, usually near 11 p.m. Also, "G. C." reports unknowns on 11.90 and 17.7 mc., phoning at 10 a.m.

#### ASIATIC REVIEW

VWY2, 17.48 mc., Poona, India, heard with inverted speech, fine signal, at 7:44 a.m. Usually contacts GAU, 18.62., Rugby, at 8 a.m., daily.

A letter from Tapeshi Saito, Tokyo, Japan, gives following data: JZ1, reported by a correspondent as having moved to 9.61 mc., is still on 9.535 mc. The station on 9.61 mc. is JFO, Taihoku, Taiwan, really on 9.625 mc. JFO relays the BC. station JFAK. Mr. Saito signs himself "a reader of S.W.&T. in Japan." Please write again, Mr. Saito!

From Japan, Mr. Gallagher, W6, reports JVD, 15.86 mc., phoning at 11 p.m. JVN, 10.66 mc., relaying programs irreg., at 1:30

(Continued on page 654)

# World Short Wave Stations

Revised Monthly

Broadcasters Calls in bold type  
Phones in light type

Reports on station changes are appreciated.

Mc.	Call	BALTIMORE, MD., 9.494 m., Relays WFBR 4 pm-12 m.	Mc.	Call	ST. ASSISE, FRANCE, 15.5 m. Calls S. America mornings.	Mc.	Call	OCEAN GATE, N. J., 17.52 m., Addr. A.T.&T.Co. Works ships irregularly.
31.600	W3XEY	BALTIMORE, MD., 9.494 m., Relays WFBR 4 pm-12 m.	19.355	FTM	ST. ASSISE, FRANCE, 15.5 m. Calls S. America mornings.	17.120	WOO	OCEAN GATE, N. J., 17.52 m., Addr. A.T.&T.Co. Works ships irregularly.
31.600	W2XDV	NEW YORK CITY, 9.494 m., Addr. Col. Broad. System, 485 Madison Ave. Daily 6-11 pm.; Sat. and Sun. 1:30-6, 7-10 pm.	19.345	PMA	BANDOENG, JAVA, 15.51 m. Works Holland 5:30-11 am.	17.080	GBC	RUGBY, ENG., 17.56 m. Works ships irregularly.
31.600	W9XHW	MINNEAPOLIS, MINN., 9.494 m. Relays WCCO 9 am-12 m.	19.260	PPU	RIO DE JANEIRO, BRAZ., 15.58 m., Addr. Cia. Radiotel. Brasileira. Works France mornings.	16.835	ITK	MOGADISCIO, ITAL. SOMALILAND, 18.32 m. Calls IAC around 9:30 am.
31.600	W3XKA	PHILADELPHIA, PA., 9.494 m., Addr. NBC. Relays KYW 12 n-10 pm.	19.220	WKF	LAWRENCEVILLE, N. J., 15.6 m., Addr. A.T.&T. Co. Calls London and Paris daytime.	16.270	WLK	LAWRENCEVILLE, N. J., 18.44 m., Addr. A.T.&T. Co. Works S. Amer. daytime.
31.600	W5XAU	OKLAHOMA CITY, 9.494 m., Sun 12 n-1 pm., 6-7 pm. Irregular other times.	19.200	ORG	RUYSSELEDE, BELGIUM, 15.62 m. Calls OPL mornings.	16.270	WOG	OCEAN GATE, N. J., 18.44 m., Addr. A.T.&T. Co. Works Eng. land late afternoon.
31.600	W4XCA	MEMPHIS, TENN., 9.494 m. Addr. Memphis Commercial Appeal. Relays WMC.	19.160	GAP	RUGBY, ENG., 15.66 m. Calls Australia 1-8 am.	16.240	KTO	MANILA, P. I., 18.47 m., Addr. RCA Comm. Works Japan and U. S. 5-9 pm. irregularly.
31.600	W8XAI	ROCHESTER, N. Y., 9.494 m., Addr. Stromberg Carlson Co. Relays WHAM 7:30-12:05 am.	18.970	GAQ	RUGBY, ENG., 15.81 m. Calls S. Africa mornings.	16.233	FZR3	SAIGON, INDO-CHINA, 18.48 m. Calls Paris early morning.
31.600	W8XWJ	DETROIT, MICH., 9.494 m., Addr. Evening News Ass'n. Relays WWJ 6-12:30 am., Sun. 8 am-12 m.	18.890	ZSS	KLIPHEUVEL, S. AFRICA, 15.88 m., Addr. Overseas Comm. of S. Africa. Ltd. Calls GAQ 9-10 am.	16.030	KKP	KAHUKU, HAWAII, 18.71 m., Addr. RCA Comm. Works Dixon 3-10 pm.
31.600	W9XPD	ST. LOUIS, MO., 9.494 m., Addr. Pulitzer Pub. Co. Relays KSD.	18.830	PLE	BANDOENG, JAVA, 15.93 m. Calls Holland early am.	15.880	FTK	ST. ASSISE, FRANCE, 18.9 m. Works Saigon 8-11 am.
26.400	W9XJL	SUPERIOR, WIS., 11.36 m. Relays WEBC daily.	18.680	OCI	LIMA, PERU, 16.06 m. Tests with Bogota, Col.	15.865	CEC	SANTIAGO, CHILE, 18.91 m. Calls Peru daytime irregular.
26.400	W9XAZ	MILWAUKEE, WIS., 11.36 m., Addr. The Journal Co. Relays WTMJ from 1 pm.	18.620	GAU	RUGBY, ENG., 16.11 m. Calls N. Y. daytime.	15.810	LSL	BUENOS AIRES, ARG., 18.98 m., Addr. (See 21,020 mc.) Works London mornings and Paris afternoons.
26.100	GSK	DAVENTRY, ENG., 11.49 m., Addr. B.B.C., London. Operates irregularly.	18.450	HBF	GENEVA, SWITZERLAND, 16.26 m., Addr. Radio Nations. Tests irregularly.	15.660	JVE	NAZAKI, JAPAN, 19.16 m. Works Java and Siam 3-5 am.
25.950	W6XKG	LOS ANGELES, CAL., 11.56 m., Addr. 8. S. McGlashan, Wash. Blvd. at Oak St. Relays KGfJ 24 hours daily.	18.345	FZS	SAIGON, INDO-CHINA, 16.35 m. Works Paris early morning.	15.620	JVF	NAZAKI, JAPAN, 19.2 m. Works Cal. near 5 am. and 8 pm.
21.550	GST	DAVENTRY, ENG., 13.92 m., Addr. (See 26.100 mc.) Irregular at present.	18.340	WLA	LAWRENCEVILLE, N. J., 16.36 m., Addr. A.T.&T. Co. Calls England daytime.	15.550	CO9XX	TUINICU, ORIENTE, CUBA, 19.29 m., Addr. Frank Jones, Central Tuinicu, Tuinicu, Santa Clara. Broadcasts irregularly evenings.
21.540	W8XK	PITTSBURGH, PA., 13.93 m., Addr. Grant Bldg. Relays KDKA 6.45-9 am. Exc. Sun.	18.299	YVR	RUGBY, ENG., 16.38 m. Calls N.Y. daytime.	15.450	IUG	ADDIS ABABA, ETHIOPIA, 19.41 m. Works Rome 9.15-10.30 am.
21.530	GSJ	DAVENTRY, ENG., 13.93 m., Addr. (See 26.100 mc.) 5.45-10.30 am.	18.250	FTO	MARACAY, VENEZ., 16.39 m. Works Germany mornings.	15.440	XEBM	MAZATLAN, SIN., MEX., 19.43 m., Addr. Flores 103 Alto. "El Pregonero del Pacifico." Irregularly 7 am-10 pm.
21.520	W2XE	NEW YORK CITY, 13.94 m., Addr. Col. Broad. Syst., 485 Madison Ave. 7.30-10 am., Sat. and Sun. 8 am-1 pm.	18.200	GAW	ST. ASSISE, FRANCE, 16.43 m. Works S. America daytime.	15.415	KWO	DIXON, CALIF., 19.46 m., Addr. A. T. & T. Co. Works Hawaii 2-7 pm.
21.470	GSH	DAVENTRY, ENG., 13.97 m. (See 26.100 mc.), 5.45 am-12 n.	18.135	PMC	RUGBY, ENG., 16.48 m. Works N.Y.C. daytime.	15.370	HAS3	BUDAPEST, HUNGARY, 19.52 m., Addr. Radiolabor, Gyali Ut 22. Sun. 9-10 am.
21.420	WKK	LAWRENCEVILLE, N. J., 14.01 m., Addr. Amer. Tel. & Tel. Co. Calls S. Amer. 7 am-7 pm.	18.115	LSY3	BANDOENG, JAVA, 16.54 m. Works Holland mornings.	15.360	DZG	ZEESSEN, GERMANY, 19.53 m., Addr. Reichspostzentralamt. Tests irregularly.
21.080	PSA	RIO DE JANEIRO, BRAZ., 14.23 m., Calls WKK daytime.	18.040	GAB	BUENOS AIRES, ARG., 16.56 m., Addr. (See 20,700 mc.) Tests irregularly. Broadcasts 5-6 pm. Friday.	15.355	KWU	DIXON, CALIF., 19.53 m., Addr. A.T.&T. Co. Phones Pacific Isles and Japan.
21.060	WKA	LAWRENCEVILLE, N. J., 14.25 m. Addr. (See 21.420 mc.) Calls England morning and afternoon.	<b>16 MET. BROADCAST BAND</b>		17.810	PCV	KOOTWIJK, HOLLAND, 16.84 m. Works Java 6-8 am.	
21.020	LSN6	BUENOS AIRES, ARG., 14.27 m., Addr. Cia. Internacional de Radio. Works N.Y.C. 7 am-7 pm.	17.800	TGWA	GUATEMALA CITY, GUAT., 16.84 m., Addr. Ministre De Fomento. Irregular.	<b>19 MET. BROADCAST BAND</b>		
20.860	EHY-EDM	MADRID, SPAIN, 14.38 m., Addr. Cia Tel. Nacional de Espana. Works S. Amer. mornings.	17.790	GSG	DAVENTRY, ENG., 16.86 m., Addr. B.B.C., London. 3.15-5.30 am., 5.45 am-12 n., 12.20-4 pm.	15.340	DJR	BERLIN, GERMANY, 19.56 m., Addr. Broadcast'g House, 8-9 am.
20.700	LSY	BUENOS AIRES, ARG., 14.49 m., Addr. Transradio Internatl. Tests irregularly.	17.785	JZL	TOKIO, JAPAN, 16.87 m. Tests irregularly.	15.330	W2XAD	SCHENECTADY, N. Y., 19.56 m., Addr. General Electric Co. Relays WGY 11 am. to 9 pm.
20.380	GAA	RUGBY, ENG., 14.72 m. Calls Arg., Brazil mornings.	17.780	W3XAL	BOUND BROOK, N. J., 16.87 m., Addr. Natl. Broad. Co. 8.55 am-6.45 pm.	15.320	OLR5B	PRAGUE, CZECHOSLOVAKIA. 19.58 m. Addr. (See 11.875 mc.) Daily ex. Sun. 6.30-7.30 am., Sun. 6-7.30 am.
20.040	OPL	LEOPOLDVILLE, BELGIAN CONGO, 14.97 m. Works ORG morn.	17.770	PHI	HUIZEN, HOLLAND, 16.88 m., Addr. (See PHI, 11.730 mc.) Daily except Wednesday, 8.25-10 am., Sun. 7.25-10.25 am.	15.310	GSP	DAVENTRY, ENG., 19.6 m., Addr. (See 26.100 mc.) 1.45-4 pm.
20.020	DHO	NAUEN, GERMANY, 14.99 m., Addr. Reichspostzentralamt. Works S. Amer. mornings.	17.760	DJE	BERLIN, GERMANY, 16.89 m., Addr. Broadcasting House. 12.05-10 am.; also Sun. 11.10 am-12.25 pm.	15.290	LRU	BUENOS AIRES, ARG., 19.62 m., Addr. El Mundo. 6-8 am.
19.900	LSG	BUENOS AIRES, ARG., 15.08 m., Addr. (See 20.700 mc.) Tests irregularly.	17.760	W2XE	NEW YORK, N. Y., 16.89 m., Addr. Col. Broad. System, 485 Madison Ave. Daily 6.20 pm-12 m.	15.280	H13X	CIUDAD TRUJILLO, D. R., 19.63 m. Relays HIX Sun. 7.40-10.40 am. Weekdays 12.10-1.10 pm.
19.820	WKN	LAWRENCEVILLE, N. J., 15.14 m., Addr. A. T. & T. Co. Calls England daytime.	17.755	ZBWS	HONGKONG, CHINA, 16.9 m., Addr. P.O. Box 200. 4-10 am. Irregular.	15.280	DJQ	BERLIN, GERMANY, 19.63 m., Addr. Broadcasting House. 12.05-10 am., 4.50-10.45 pm. Also Sun. 11.10 am-12.25 pm.
19.680	CEC	SANTIAGO, CHILE, 15.24 m., Addr. Cia. Internacional de Radio. Calls Col. and Arg. daytime.	17.741	HSP	BANGKOK, SIAM, 16.91 m. Works Germany 3-5 am., 8-9 pm. Works JVE 11 pm-6 am.	15.270	W2XE	NEW YORK CITY, 19.65 m., Addr. (See 21.520 mc.) Daily except Sat. and Sun., 1-2.15 pm.
19.650	LSN5	BUENOS AIRES, ARG., 15.27 m., Addr. (See 21.020 mc.) Calls Europe daytime.	17.650	XGM	SHANGHAI, CHINA, 17 m. Works London 7-9 am.	15.260	GSI	DAVENTRY, ENG., 19.66 m., Addr. (See 26.100 mc.) 12.20-4 pm.
19.620	VQG4	NAIROBI, KENYA, 15.28 m., Addr. Cable and Wireless, Ltd. Calls London 7.30-8 am.	17.520	DFB	NAUEN, GERMANY, 17.12 m. Works S. America, near 9.15 am. Works Siam 3-5 am., 8-9 pm.	15.252	RIM	TACHKENT, U.S.S.R., 19.67 m. Works RKI near 7 am.
19.600	LSF	BUENOS AIRES, ARG., 15.31 m., Addr. (See 20.700 mc.) Tests irregularly.	17.480	VWY2	KIRKEE, INDIA, 17.16 m. Works London 7.30-8.15 am.	15.250	WIXAL	BOSTON, MASS., 19.67 m., Addr. University Club. Daily 2.15-4 pm., Sun. 10.15 am-12 n.
19.480	GAD	RUGBY, ENG., 15.4 m. Calls VQG4 7.30-8 am.	17.310	W2XGB	HICKSVILLE, L. I., N. Y., 17.33 m., Addr. Press Wireless, Box 296. Tests 9.30-11.30 am. except Sat. and Sun.	15.245	TPA2	PARIS, FRANCE, 19.68 m., Addr. 98 bis, Blvd. Haussmann. "Radio Colonial." 6-11 am.
						15.230	HS8PJ	BANGKOK, SIAM, 19.7 m. Irregularly Mon. 8-10 am.

(Continued on page 620)

All Schedules Eastern Standard Time

# Question Box

A fee of 25c (stamps, coin or money order) is charged for letters that are answered by mail. This fee includes only hand-drawn schematics. We cannot furnish full-size working drawings or picture layouts. Letters not accompanied by 25c will be answered on this page. Questions involving considerable research will be quoted upon request. Names and addresses should be clearly printed on each letter.

## WAVE-TRAP

Will you please publish a circuit for a wave-trap to eliminate code interference on the 20 meter Ham-band.—Louis Oberdoester, Allentown, Pa.

The circuit of a satisfactory wave-trap is shown on this page. This trap is connected in series with the antenna lead to the receiver and consists of a coil and condenser which resonate in the 20-meter band.

To eliminate code interference turn the receiver on and adjust the wave-trap's tuning condenser until the interference disappears. Data for the coils is given in the sketch. This wave-trap will not affect the operation of the receiver in any way aside from eliminating this interference.

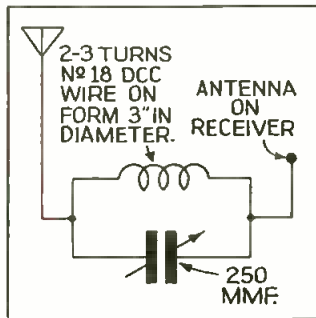

Wave Trap—1112

## COIL WINDING DATA

Please print the coil data for 2- and 3-winding coils (4- and 6-prong) covering the range from 15-200 meters. These coils should be for use with 140 mmf. tuning condensers.—J. K. Smith, Cleveland, O.

We are printing the data you request. The coil data shown is suitable for use with any of the receivers which have been described on this page and elsewhere in the magazine in the past. All coils are for 140 mmf. tuning condensers.

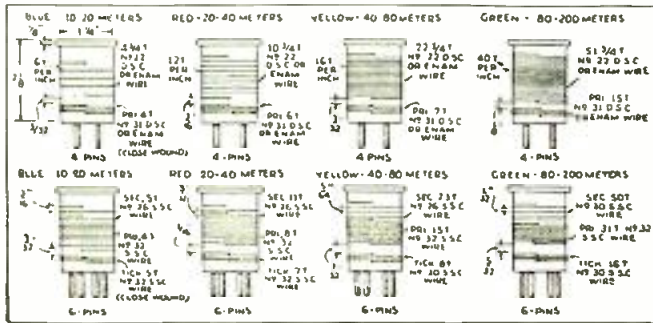

Plug-In Coil Data—1113

## 5 TUBE RECEIVER

I would like to know if you have a diagram for a 3-tube 5-meter receiver using the following 6.3 volt tubes: 78, 37 and 42. This receiver should use a 15 mmf. tuning condenser and have an audio volume control.—George J. Lhota, Cleveland, Ohio.

We have diagrammed the 3-tube receiver meeting your specifications. A 78 tube is used as detector and a 37 as a quenching oscillator. A 42 is used as the A. F. amplifier. Regeneration is controlled by a 50,000 ohm potentiometer and volume by a

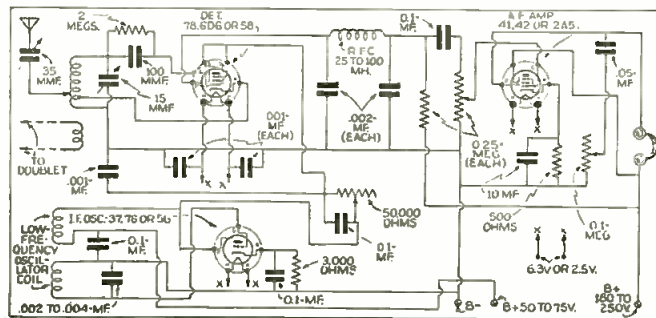

Ultra Short Wave Set—1115

## SUPERHET DESIGN

I am planning to build a short-wave superhet and would appreciate some information on two points. 1.—Which is best, 2 stages of I.F. using air-core I.F. transformers, or 1 stage using iron-core transformers? 2.—Which would give best results, 2 stages of I.F. or 1 stage of I.F. and 1 stage of R.F.—Albert Cole, Ottawa, Canada.

In answer to your first question may we say that there is not much difference in performance between the two I.F. arrangements you have mentioned. The single stage using an I.F. transformer will give approximately as good results as two stages using an air-core transformer. The simplicity of the single-stage arrangement and the fewer parts required make

it the most practical arrangement.

In answer to the second question, the stage of R.F. ahead of the first detector will result in a considerable improvement in signal-to-noise ratio in a receiver and will also minimize image reception. For this reason the best combination is the single I.F. stage with iron-core transformers in conjunction with an R.F. stage.

## A 5-TUBE T.R.F. RECEIVER

I wish to build a 5-tube T.R.F. receiver using a 58 T.R.F. amplifier, 57 detector, 56 first A.F. and 2—2A5's in push-pull for

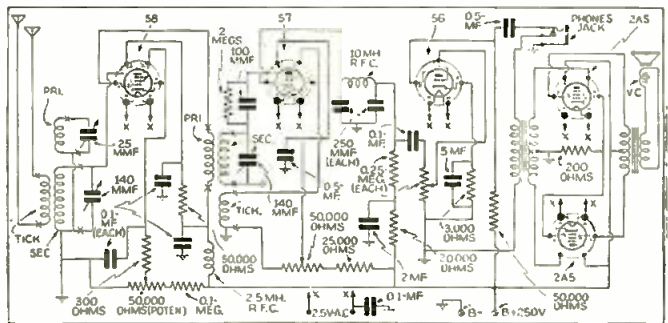

TRF Receiver—1114

the second A.F. There should be an R.F. gain control in addition to regeneration and audio volume control. Should the tuning condensers be of the gang type or must they be separate in order to minimize inter-action? If possible, I should like to have some sort of switching arrangement.—Saul Wolfman, Toronto, Canada.

We have prepared the circuit of a receiver meeting your requirements. The two tuning condensers may be ganged as it is not necessary to shield them. The tuning coils, however, should be shielded from each other. It is possible to use a switching arrangement with this circuit, but as it would involve quite a complicated design, we would not recommend it. Plug-in coils offer a much simpler solution. Coil winding data (6 prong) appears on another part of this page. The R.F. and Det. tubes should of course be shielded. The 25 mmf. condenser in shunt with the extra primary winding on the antenna coil is for the purpose of trimming the R.F. stage. The output transformer should have a primary impedance of 14,000 ohms from plate to plate.

Mc. Call		Mc. Call		Mc. Call	
15.230 OLR5A	PRAGUE, CZECHOSLOVAKIA, 19.7 m., 6.30-7.30 am, Sun. 6-7.30 am.	14.440 GBW	RUGBY, ENG., 20.78 m. Works U.S.A. afternoons.	11.855 DJP	BERLIN, GERMANY, 25.31 m., Addr. [See 15.280 mc.] Irregular 11.35 am-4, 7-10.45 pm.
15.220 PCJ	HUIZEN, HOLLAND, 19.71 m., Addr. N. V. Philips' Radio Hilversum. Tues. 3.30-5 am., Wed. 9 am-12 n.	14.200 EA9AH	TETUAN, SPANISH MOROCCO, 21.13 m. Daily except Sun. 2.15-5, 7 and 9 pm.	11.840 KZRM	MANILA, P. I., 25.35 m. Addr. Erlanger & Gallinger, Box 283. 9 pm-10 am. Irregular.
15.210 W8XK	PITTSBURGH, PA., 19.72 m., Addr. (See 21.540 mc.) 9 am-7 pm.	14.166 PIJ	DORDRECHT, HOLLAND, 21.15 m., Addr. (See 7.088 mc.) Sat. 12 n-12.30 pm.	11.840 CSW	LISBON, PORT., 25.35 m. Nat'l Broad. Station. 11.30 am-1.30 pm. Irregular.
15.200 DJB	BERLIN, GERMANY, 19.74 m., Addr. (See 15.280 mc.) 4.50-10.45 pm. Also Sun. 11.10 am-12.15 pm.	13.990 GBA	RUGBY, ENG., 21.44 m. Works Buenos Aires late afternoon.	11.840 OLR4A	PRAGUE CZECHOSLOVAKIA, 25.35 m., Addr. Czech Shortwave Sta., Praha XII, Fochova 16.
15.190 Z8W4	HONGKONG, CHINA, 19.75 m., Addr. P. O. Box 200. Irregular. 11.30 pm. to 1.15 am., 4-10 am., Sat. 9.15 pm-1 am., Sun. 3-9.30 am.	13.820 SUZ	ABOU ZABAL, EGYPT, 21.71 m. Works with Europe 11 am-2 pm.	11.830 W9XAA	CHICAGO, ILL., 25.36 m., Addr. Chicago Federation of Labor. Irregular 7 am-6 pm.
15.180 GSO	DAYENTRY, ENG., 19.76 m., Addr. (See 26.100 mc.) 3.15-5.30, 5.45-10 am., 4.15-6 pm.	13.690 KKZ	BOLINAS, CALIF., 21.91 m., Addr. RCA Comm. Irregularly.	11.830 W2XE	NEW YORK CITY, 25.36 m., Addr. Col. Broad. System, 485 Madison Av., N.Y.C. Daily 2.30-6 pm.
15.170 TGWA	GUATEMALA CITY, GUAT., 19.77 m., Addr. (See 17.8 mc.) Irregular 11.30 am-2 pm.	13.635 SPW	WARSAW, POLAND, 22 m., Mon., Wed., Fri. 12.30-1.30 pm. Daily 6-7 pm.	11.820 XE8R	HERMOSILLA, SON., MEX., 25.38 m., Addr. Box 68. Relays XEBH-2-4 pm., 9 pm-12 m.
15.165 XEWW	MEXICO CITY, MEXICO, 19.78 m., 12 n-12 m. Irregular.	13.585 GBB	RUGBY, ENG., 22.08 m. Works Egypt and Canada afternoons.	11.820 GSN	DAYENTRY, ENG., 25.38 m., Addr. (See 26.100 mc.) Irregular.
15.160 JZK	TOKIO, JAPAN, 19.79 m. Irregular.	13.415 GCJ	RUGBY, ENG., 22.36 m. Works Japan and China early morning.	11.810 ZRO	ROME, ITALY, 25.4 m., Addr. E.I.A.R., Via Montello 5. Daily 5-8.30 am., 10.30 am-12.20 pm.
15.155 SM5SX	STOCKHOLM, SWEDEN, 19.79 m., daily at 11 am.	13.410 YSJ	SAN SALVADOR, SALVADOR, 22.37 m. Works WNC daytime.	11.805 OZG	SKAMLEBOAEK, DENMARK, 25.41 m., Addr. Statsradiofonien. Irreg.
15.150 YDC	BANDOENG, JAVA, 19.8 m., Addr. N. I. R. O. M. 6-7.30 pm., 10.30 pm-2 am., Sat. 7.30 pm-2 am., 5.30-10.30 am.	13.390 WMA	LAWRENCEVILLE, N. J., 22.4 m., Addr. A.T.&T. Co. Works England morning and afternoon.	11.800 JZJ	TOKIO, JAPAN, 25.42 m., Addr. Broadcasting Co. of Japan, Overseas Division. 12.30-1.30, 7-7.30, 8-9.30 am., 2.30-4, 4.30-5.30, 6-6.30 pm.
15.140 G5F	DAYENTRY, ENG., 19.82 m., Addr. (See 26.100 mc.) 5.45 am-12 n.	13.380 IDU	ASMARA, ERITREA, AFRICA, 22.42 m. Works Rome daytime.	11.800 OER3	VIENNA, AUSTRIA, 25.42 m. Daily 10 am-5 pm. Sat. until 5.30 pm.
15.120 HVJ	VATICAN CITY, 19.83 m., 10.30-10.45 am., except Sun., Sat. 10-10.45 am.	13.345 YVQ	MARACAY, VENEZUELA, 22.48 m. Works WNC daytime.	11.795 DJO	BERLIN, GERMANY, 25.43 m., Addr. (See 15.280 mc.) Irregular.
15.110 DJL	BERLIN, GERMANY, 19.85 m., Addr. (See 15.280 mc.) 12 m.-2, 8-9 am., 10.40 am. to 4.30 pm. Sun. also 6-8 am.	13.285 CGA3	DRUMMONDVILLE, QUE, CAN., 22.58 m. Works London and ships afternoons.	11.795 OAX5B	ICA, PERU, 25.43 m., Addr. Radio Universal. 11 am-12 n., 4-11.15 pm.
15.055 WNC	HAIALEH, FLORIDA, 19.92 m., Addr. A.T.&T. Co. Calls Central America daytime.	13.330 IRJ	ROME, ITALY, 22.69 m. Works Tokio 5-9 am. Irregularly.	11.790 COGF	MATANZAS, CUBA, 25.45 m., Addr. Gen. Betancourt 51. Relays CMGF. 2-3, 4-5, 6-11 pm.
15.038 RKI	MOSCOW, U.S.S.R., 19.95 m. Works Tashkent near 7 am. Broadcasts Sun. 12.15-2.30 pm.	13.075 VPD	SUYA, FIJI ISLANDS, 22.94 m. Irregularly.	11.790 WIXAL	BOSTON, MASS., 25.45 m., Addr. (See 15.250 mc.) Daily 4.45-6.30 pm., Sat. 1.45-5.15, 6-6.30 pm., Sun. 3-6.30 pm.
14.980 KAY	MANILA, P. I., 20.03 m., Addr. RCA Comm. Works Pacific Is.	12.840 WOO	OCEAN GATE, N. J., 23.36 m., Addr. A.T.&T. Co. Works with ships irregularly.	11.770 DJD	BERLIN, GERMANY, 25.49 m., Addr. (See 15.280 mc.) 10.40 am-4.30 pm., 4.50-11 pm.
14.970 LZA	SOPHIA, BULGARIA, 20.04 m., Addr. Radio Gara. Mon., Tues., Thurs., Fri. 11.30 am-2.45 pm., Wed. 11.30 am-4.45 pm., Sat. 11.30 am-5 pm., Sun. 2 am-5 pm. Daily except Sun. 5-6.30 am.	12.825 CNR	RABAT, MOROCCO, 23.39 m., Addr. Director General Tele. & Teleg. Stations. Works with Paris irregularly.	11.760 TGWA	GUATEMALA CITY, GUAT., 25.51 m., (See 17.8 mc.) Sun., Tues. and Thurs. 8 pm-12 m.
14.960 PSF	RIO DE JANEIRO, BRAZIL, 20.05 m., Works with Buenos Aires daytime.	12.800 IAC	PISA, ITALY, 23.45 m. Works Italian ships mornings.	11.760 OLR4B	PRAGUE, CZECHOSLOVAKIA, 25.51 m., Addr. (See 11.875 mc.) Irregular.
14.950 HJB	BOGOTA, COL., 20.07 m. Calls WNC daytime.	12.780 GBC	RUGBY, ENG., 23.47 m. Works ships irregularly.	11.750 GSD	DAYENTRY, ENG., 25.53 m., Addr. B.B.C., London. 3.15-5.30, 10.45 am-12 n., 12.20-6.00 pm., 6.20-8.30, 9.15-11.15 pm.
14.940 HII	CIUDAD TRUJILLO, D. R., 20.08 m. Phones WNC daytime.	12.325 DAF	NORDDEICH, GERMANY, 24.34 m. Works German ships daytime.	11.730	SAIGON, INDO CHINA, 25.57 m., Addr. Radio Philco. 11 pm-1 am., 5.30-9.30 am.
14.940 HJA3	BARRANQUILLA, COL., 20.08 m. Works WNC daytime.	12.300 CB615	SANTIAGO, CHILE, 24.39 m., Addr. Louis Desmaras, Casilla, 761. 11 am-1 pm., 4-8 pm., Sun. 4-10 pm.	11.730 PHI	HUIZEN, HOLLAND, 25.57 m., Addr. N. V. Philips' Radio.
14.845 OCJ2	LIMA, PERU, 20.21 m. Works South America stations daytime.	12.290 GBU	RUGBY, ENG., 24.41 m. Works N. Y. C. evenings.	11.720 CJRX	WINNIPEG, CANADA, 25.6 m., Addr. James Richardson & Sons. Ltd. 4-10 pm.
14.790 ROU	OMSK, SIBERIA, U.S.S.R., 20.28 m. Works Moscow irregularly 7-9 am.	12.250 TYB	PARIS, FRANCE, 24.49 m. Irregular.	11.718 CR7BH	LAURENÇO MARQUES, PORTUGESE, E. AFRICA, 25.6 m. Daily 12.05-1, 4.30-6.30, 9.30-11 am., 12.05-4 pm., Sun. 5-7 am., 10 am-2 pm.
14.730 IQA	ROME, ITALY, 20.37 m. Broadcasts 6-9 pm.	12.235 TFJ	REYKJAVIK, ICELAND, 24.52 m. Works Europe mornings. Broadcasts Sun. 1.40-2.30 pm.	11.715 TPA4	PARIS, FRANCE, 25.61 m., (See 15.245 mc.) 6.15-8.15 pm., 10 pm-1 am.
14.653 GBL	RUGBY, ITALY, 20.47 m. Works JWH 1-7 am.	12.215 TYA	PARIS, FRANCE, 24.56 m. Works French ships in morning and afternoon.	11.710 SBG	MOTALA, SWEDEN, 25.63 m., 1.20-2.05, 8-9 am., 11 am-1.30 pm.
14.640 TYF	PARIS, FRANCE, 20.49 m. Works Saigon and Cairo 3-7 am, 12 n-2.30 pm.	12.150 GBS	RUGBY, ENG., 24.69 m. Works N. Y. C. evenings.	11.710 XEWB	GUADALAJARA, MEX., 25.63 m., Addr. Juarez 289. Irregular.
14.600 JVH	NAZAKI, JAPAN, 20.55 m. Broadcasts irregularly 5-11.30 pm. Works Europe 4-8 am.	12.130 DZE	ZEESEN, GERMANY, 24.73 m., Addr. (See 15.360 mc.) Tests irregular.	11.710 YSM	SAN SALVADOR, EL SALVADOR, 25.63 m., Addr. (See 7.894 mc.) Irregular 1.30-2.30 pm.
14.590 WMN	LAWRENCEVILLE, N. J., 20.56 m., Addr. A.T.&T. Co. Works England morning and afternoon.	12.120 TPZ2	ALGIERS, ALGERIA, 24.75 m. Calls Paris 12 m.-6.30 am.	11.700 HP5A	PANAMA CITY, PAN., 25.65 m., Addr. Radio Teatro, Apartado 954. 10 am-10 pm.
14.535 HBJ	GENEVA, SWITZERLAND, 20.64 m., Addr. Radio Nations. Broadcasts Sat. 6.45-8 pm.	12.060 PDV	KOOTWIJK, HOLLAND, 24.88 m. Tests irregularly.	11.700 CB1170	SANTIAGO, CHILE, 25.65 m. Relays C889 6 pm-12 m.
14.530 LSN	BUENOS AIRES, ARG., 20.65 m., Addr. (See 20.020 mc.) Works N. Y. C. afternoons.	12.000 RNE	MOSCOW, U.S.S.R., 25 m. Daily 6-7 am., 12.15-1 pm., 8.30-11 pm., also Sun. 6 am-1 pm.	11.680 KIO	KAHUKU, HAWAII, 25.68 m., Addr. RCA Comm. Irregularly.
14.500	ASMARA, ERITREA, AFRICA, 20.69 m., Works Rome and Addis Ababa 6.30-7.30 am.	11.991 FZS2	SAIGON, INDO-CHINA, 25.02 m. Phones Paris mornings.	11.595 VRR4	STONY HILL, JAMAICA, B. W. I., 25.87 m. Works WNC daytime.
14.500 LSM2	BUENOS AIRES, ARG., 20.69 m., Addr. (See 21.020 mc.) Works RIO and Europe daytime.	11.960 H12X	CIUDAD TRUJILLO, D. R., 25.08 m., Addr. La Voz de Hispaniola. Relays HIX Tue. and Fri. 8.10-10.10 pm.	11.560 VIZ3	FISKDALE, AUSTRALIA, 25.95 m., Addr. Amalgamated Wireless of Australasia Ltd. Tests irregularly.
14.485 TIR	CARTAGO, COSTA RICA, 20.71 m. Works Central America and U. S. A. daytime.	11.955 IUC	ADDIS ABABA, ETHIOPIA, 25.09 m. Works IAC around 12 m.	11.530 SPD	WARSAW, POLAND, 26 m., Addr. 5 Mazowiecka St. Testing daily 6-7 pm.
14.485 YSL	SAN SALVADOR, SALVADOR, 20.71 m. Irregular.	11.950 KKQ	BOLINAS, CALIF., 25.1 m. Tests irregularly evenings.	11.500 XAM	MERIDA, YUCATAN, 26.09 m. Irregular 1-7.30 pm.
14.485 HPF	PANAMA CITY, PANAMA, 20.71 m. Works WNC daytime.	11.940 FTA	STE. ASSISE, FRANCE, 25.13 m. Works Morocco mornings and Argentina late afternoon.	11.500 PMK	BANDOENG, JAVA, 26.09 m. Tests irregularly.
14.485 TGF	GUATEMALA CITY, GUATEMALA, 20.71 m. Works WNC daytime.	<b>25 MET. BROADCAST BAND</b>		11.435 COCX	HAYANA, CUBA, 26.21 m. P. O. Box 32. 6.55 am-1 am. Sun. till 12 m. Relays CMX.
14.485 YNA	NICARAGUA, MANAGUA, 20.71 m. Works WNC daytime.	11.910 CB1190	VALDIVIA, CHILE, 25.2 m., P. O. Box 642. Relays C869 11 am-11 pm.	11.413 CJA4	DRUMMONDVILLE, QUE, CAN., 26.28 m. Tests irregularly.
14.485 HRL5	NACAOME, HONDURAS, 20.71 m. Works WNC daytime.	11.900 XEW1	MEXICO CITY, MEXICO, 25.21 m., Addr. P. O. Box 2874. Tues. and Thurs. 7.30 pm-12 m., Fri. 9 pm-12 m. Sun. 12.30-2 pm.	11.402 HBO	GENEVA, SWITZERLAND, 26.31 m., Addr. Radio Nations. Sat. 6.45-8 pm.
14.485 HRF	TEGUCIGALPA, HONDURAS, 20.71 m. Works WNC daytime.	11.895 HP51	AGUADULCE, PANAMA, 25.22 m., Addr. La Voz del Interior. 7.30-9.30 pm.		
14.470 WMF	LAWRENCEVILLE, N. J., 20.73 m., Addr. A.T.&T. Co. Works London and Paris daytime.	11.880 TPA3	PARIS, FRANCE, 25.23 m., Addr. (See 15.245 mc.) 2-5 am., 12.15-6 pm.		
14.460 DZH	ZEESEN, GERMANY, 20.75 m., Addr. (See 15.360 mc.) Irregular.	11.870 W8XK	PITTSBURGH, PA., 25.26 m., Addr. (See 21.540 mc.) 7-11 pm.		
		11.860 YDB	SOERABAJA, JAVA, 25.29 m., Addr. N. I. R. O. M. Sat. 7.30 pm to 2.30 am., daily 10.30 pm. to 2 am.		
		11.860 GSE	DAYENTRY, ENG., 25.29 m., Addr. (See 26.100 mc.) Irregular.		

(Continued on page 622)

All Schedules Eastern Standard Time

# How To Identify Short Wave Stations

## Keep These Lists for Future Reference

- | FREQ.  | CALL   | TYPE | LOCATION   |
|--------|--------|------|--|
| 6.30   | YV4RD  | B    | Maracay, Venezuela.<br>Slogan "La voz de Aragua," uses dual call "YV4RD y YV4RG."  |
| 6.295  | OAX4G  | B    | Lima, Peru.<br>Signature song "Good Night." Melody, male vocal in English. Uses dual call "OAX4B y OAX4G."   |
| 6.282  | COHB   | B    | Sancti Spiritus, Cuba.<br>Uses dual call "CMHB y COHB."  |
| 6.28   | HIG    | B    | Trujillo City, D.R.<br>For a while used identification sound of a bawling calf; this station not heard lately.   |
| 6.27   | YV5RP  | B    | Caracas, Venezuela.<br>Slogan "La voz de la Philco." Uses dual call "YV5RP y YV5RQ."   |
| 6.256  | YV5RJ  | B    | Caracas, Venezuela.<br>"La voz de la Esfera." Dual call "YV5RI y YV5RJ."   |
| 6.243  | HIN    | B    | Trujillo City, D.R.<br>Slogan "Broadcasting Nacionales." Uses English at intervals.  |
| 6.235  | HRD    | B    | La Ceiba, Honduras.<br>"La voz de Atlantida." Opens with marimba selection "Solo Tuyo." Closes with Ted Lewis "Good Night" melody, played on piano.  |
| 6.225  | YVIRG  | B    | Valera, Venezuela.<br>Slogan "Radio Valera."   |
| 6.210  | ZGE    | B    | Kuala Lumpur, Fed. Malay States.<br>Announces "This is the Malayan Amateur Radio Society, Kuala Lumpur," followed by call and wavelength. Signs off with "God Save the King."  |
| 6.205  | YVIRI  | B    | Coro, Venezuela.<br>Slogan "Radio Coro."   |
| 6.20   | H18Q   | B    | Trujillo City, D.R.<br>Slogan "Emisora Carta Real, la voz de los Muchachos."   |
| 6.19   | H11A   | B    | Santiago, Dom. Rep.<br>Slogan "La voz del Yaque." Closes with "Anchors Aweigh." Interval signal is a gong.   |
| 6.172  | XEXA   | B    | Mexico City, New Mexico.<br>Opens and closes with song "March of the Toys," by Victor Herbert.   |
| 6.156  | YV5RD  | B    | Caracas, Venezuela.<br>"Radiodifusora Venezuela." Dual call "YV5RB y YV5RD."   |
| 6.15   | H15N   | B    | Moca City, D.R.<br>Slogan "La voz de Moca." In English, "The voice of Moca in Moca City, Dominican Republic."  |
| 6.15   | ZRD    | B    | Durban, So. Africa.<br>Mentions "South African Broadcasting Corp., Durban." Setting-up exercises heard around midnight, E.S.T. Language also used is Afrikaans.  |
| 6.145  | HJ4ABE | B    | Medellin, Colombia.<br>"La voz de Antioquia." Relays HJ4ABK. Uses 4 chimes, like NBC, but last note higher.  |
| 6.137  | CR7AA  | B    | Lourenco Marques, Mozambique.<br>All announcements in English and Portuguese, identifies in English at beginning, middle and end of transmission as follows: "This is Lourenco Marques, CR7AA, calling on 6137 kc., 48.88 meters, and CR7BH, testing on 25.60 meters, 11718 kc." Man announcer on week days, woman announcer in English on Sundays. Begins broadcast with various march songs, no definite "sign-off" selection. |
| 6.132  | VP3BG  | B    | Georgetown, British Guiana.<br>Signs off with "God Save the King."   |
| 6.13   | LKJ1   | B    | Jeloy, Norway.<br>Calls "Hello, hello, Oslo calling," followed by short piano selection.   |
| 6.13   | COCD   | B    | Havana, Cuba.<br>Slogan "La voz del Aire," uses dual call "CMCD y COCD."   |
| 6.125  | CXA4   | B    | Montevideo, Uruguay.<br>Gives call as "Say eckees ah quatro, Montevideo."  |
| 6.125  | XEPW   | B    | Mexico City, New Mexico.<br>Slogan "La voz del Aguila Azteca."   |
| 6.125  | HP5H   | B    | Panama City, Panama.<br>Slogan "Radio-difusora, Panama-Americana."   |
| 6.117  | XEUZ   | B    | Mexico City, Mexico.<br>"Radio Nacionales," dual call "XEFO y XEUZ."   |
| 6.11   | VPB    | B    | Colombo, Ceylon.<br>Announcement at change of program—"Colombo calling."   |
| 6.11   | VUC    | B    | Calcutta, India.<br>Opens broadcast with Time Signal, and gives time signal frequently throughout program.   |
| 6.108  | HJ6ABB | B    | Manizales, Colombia.<br>Formerly HJ4ABB. Slogan "Radio Manizales." Bells often heard.  |
| 6.10   | YUA    | B    | Belgrade, Yugoslavia.<br>Slogan "Radio Belgrade."  |
| 6.0975 | ZRJ    | B    | Maraisburg, Near Johannesburg, So. Africa.<br>Announces "So. African Broadcasting Corp., Maraisburg." Setting up exercises near midnight. Uses English and Afrikaans.  |
| 6.0975 | ZRK    | B    | Klipheuwel, So. Africa.<br>Announces "So African Broadcasting Corp., Klipheuwel." Rest same as for ZRJ.  |
| 6.09   | HJ4ABC | B    | Ibague, Colombia.<br>Slogan "Ecos del Combeima."   |
| 6.085  | HJ5ABA | B    | Cali, Colombia.<br>Slogan "La voz del Valle."  |
| 6.085  | VUD    | B    | Delhi, India.<br>Announces as "Delhi, VUD."  |
| 6.083  | VQ7LO  | B    | Nairobi, Kenya.<br>Announces "VQ7LO, Nairobi station of the East Africa Broadcasting Company calling." Signs off with "God Save the King."   |
| 6.081  | YVIRD  | B    | Maracaibo, Venezuela.<br>Formerly YV7RMO. "Radiodifusora Maracaibo," dual call "YVIRD y YVIRE."  |

## Can You Answer These Radio Questions?

1. With the present frequencies used for transmission, about what per cent of a transmitter's power is converted into useful radiation? See page 597.
2. At what distance have ultra-short wave police stations been heard? See page 598.
3. What type of scanning, mechanical disc or cathode ray, is used for the new German television-telephone service? See page 599.
4. How will television images be picked up by the new NBC mobile van and flashed to the transmitting station—by coaxial cable or ultra-short waves? See page 600.
5. What is the tuning range in meters of the equipment carried by pilot ship guiding planes between Europe and South America? See page 601.
6. How can an iron-core choke coil be used to regulate the speed of a motor? See page 602.
7. How may a 2-stage vacuum tube amplifier be used to boost the sensitivity of an induction balance? See page 603.
8. What is the purpose of the video amplifier in a cathode ray television receiver? See page 606.
9. How would you make a simple yet effective relay from the parts of an ordinary spark coil? See page 610.
10. How would you go about making an emergency variable condenser? See page 611.
11. What are some of the causes of noisy radio reception? See page 612.
12. Can you explain in a few words how the newest system of inductive tuning operates? See page 614.
13. What is one of the first steps in preparing to align the stages of an all-wave superhet? See page 615.
14. How would you make a simple wave-trap to eliminate code signal interference on the 20-meter ham band? See page 619.





# Short Wave League

## HONORARY MEMBERS

Dr. Lee de Forest      Manfred von Ardenne  
 D. E. Replogle        E. T. Somerset  
 John L. Reinartz       Hollis Baird  
 Hugo Gernsback, Executive Secretary



Broadcasting House, London, where Daventry programs originate.

## WHEN TO LISTEN IN

M. Harvey Gernsback

All schedules in Eastern Standard Time

**AFRICA AGAIN . . .** A letter from the South African Broadcasting Corp. clears up some mysteries. A new 5 kw. station at Roberts Heights near Pretoria with call ZRH operates on 9.523 mc. daily exc. Sat. from 11.45 pm. to 12.45 am. and daily except Sunday from 5-7.30 am. and on 6.007 mc. from 10 am.-4 p.m. (Saturday till 4.45 p.m.) On Sundays the schedule is 9.523 mc. 3 or 3.30 to 4 or 4.30 a.m. (variable) and 8 a.m.-12 n. On 6.007 mc. from 12.15 to 3.15 p.m. The call letters of the Klipheuvall station are ZRK. Power is 5 kw. The Johannesburg station's call is now ZRJ. Power is 200 watts. Schedules of Johannesburg and Klipheuvall are as published in the station list in this magazine. Another station is ZRD at Durban on 6.15 mc. This station operates daily except Saturday 11.45 p.m.-12.45 a.m. Daily except Sunday 3.30-7.30 a.m., 9 a.m.-3.45 p.m. Sun. 8-11.30 a.m., 12 n.-3.20 p.m. Power is 10 watts. ZRH is being heard even better than ZRK from 11.45 p.m.-12.45 a.m. on 9.523 mc.

**ROME on 20 METERS . . .** 2RO has been using IQA on 14.73 mc. to relay its programs from 6-9 p.m. daily in addition to the 9.635 mc. channel. At present IQA is not heard well in New York.

**HAVANA . . .** It seems to be the Cubans' aim to have a short-wave station for every cigar they manufacture. Every time ye editor takes his feet off the desk a new Cuban is reported. The latest is COCA at Havana on 9.095 mc. Address is Galiano No. 102. COCA relays CMCA from 7.55 a.m.-12 m. One of our Cuban readers informs us that most Cuban stations are playing a new game called "jumping frequency." The idea is to see if the listener can follow the station's meanderings as it tries out a new wave every day or so! So not much reliance can be placed on their listed frequencies at present.

News Broadcasts in English from Abroad	
ENGLAND	
3.55, 8.30, 11 am., 1, 4.15, 7.40 and 10.25 pm.	
GERMANY	
2, 7, 9 am., 2, 4, 8.15, 10.30 pm.	
FRANCE	
4.40, 7 am., 3.10, 11.30 pm.	
AUSTRALIA	
(VLR) 4.20, 7.30 am. exc. Sun.; 9.35 pm. exc. Sat.	
JAPAN	
12.30, 8 am., 3, 6 pm.	
CZECHOSLOVAKIA	
Daily 4 pm.; Mon., Wed., Fri. 9.45 pm.	
ITALY	
6, 11 am., 2.40 and 7.35 pm.	
U.S.S.R.	
(RAN) 7 pm.	
POLAND	
(13.62 & 11.53 mc.) 6 pm.	
YUGOSLAVIA	
(6.11 mc.) 4.30 pm.	
CANARY ISLES	
(10.37 mc.) 8 pm.	
SOUTH AFRICA	
(952, 9.61 mc.) 12 m. (Exc. Sat.) 3 pm. on 6.007 & 6.097 mc.	

### Additions to Station List

Mc.	Call	Location
31.6	W9XHW	MINNEAPOLIS, MINN.
15.320	OLRSB	PRAGUE, CZECHOSLOVAKIA
15.155	SM5SX	STOCKHOLM, SWEDEN
9.523	ZRH	ROBERTS HEIGHTS, S. AFRICA
9.095	COCA	HAVANA, CUBA
8.665	W2XGB	HICKSVILLE, N. Y.
6.150	ZRD	DURBAN, SOUTH AFRICA
6.007	ZRH	ROBERTS HEIGHTS, S. AFRICA

**MINNEAPOLIS STEPS OUT . . .** into the 31.6 mc. ultra-short wave channel with W9XHW. Programs from CBS broadcast station WCCO are aired daily from 9 a.m. to 12 m.

**SWEDEN . . .** SM5SX formerly on the 25 meter band may now be heard on 15.155 mc. from 11 a.m. on. SM5SX is operated by the Royal Technical University, Stockholm.

**ATTENTION LINGUISTS . . .** Daventry has gone into the *foreign* language field in a big way. Arabic programs are broadcast daily from 12.17 to 1.15 p.m. on 9.58 mc. These are for the purpose of combating the propaganda broadcasts from the Italian stations in Arabic. Programs in Spanish and Portuguese are sent out for South Americans on GSB from 8.30 to 9 p.m. Other programs are in the process of preparation. The "war of the words" promises more excitement in the future.

**CZECHOSLOVAKIA . . .** OLR at Prague was heard on 6.03 mc. during the afternoon and evening transmission periods in January.

**SPANISH STATIONS . . .** reported are Radio Norte on 7.05 mc., 4-6 p.m. irregular; Radio Espana on 7.25 mc., 3.30-6 p.m. irregular and Radio Requeete, Madrid, on 7.1 mc., 4-6 p.m. also irregular. EAR at Madrid now comes on the air at 7.30 p.m. daily. On Mon., Tues., Thurs. and Sat. it also returns to the air again at 9.30 p.m.

**BOSTON . . .** W1XX on 9.57 mc. has a new program of interest to DX listeners everywhere called "Radio—Round the Clock." The program is broadcast every Monday at 4 p.m. Information on schedules and activities of short-wave stations all over the world is given as well as the best time for listening for various stations, information on special broadcasts and literature available to every short-wave fan.

Mc.	Call	Mc.	Call	Mc.	Call
9.330	OAX4J LIMA, PERU, 32.15 m., Addr. Box 1166, "Radio Universal." 12 n.-3 pm., 5 pm.-1 am.	7.550	T18WS PUNTA ARENAS, COSTA RICA, 39.74 m., Addr. "Ecos Del Pacifico", P. O. Box 75. 6 pm.-12 m.	6.477	H14V SAN FRANCISCO DE MACÓRIS, D. R., 46.32 m. 11.40 am.-1.40 pm., 5.10-9.40 pm.
9.300	YNGU MANAGUA, NICARAGUA, 32.26 m. 12 n.-2 pm., 6-7 pm.	7.520	KKH KAHUKU, HAWAII, 39.87 m. Works with Dixon and broadcasts irregularly nights.	6.470	YNLAT GRANADA, NICARAGUA, 46.36 m., Addr. Leonidas Tenoria, "La Voz del Mombacho." Irregular.
9.280	GCB RUGBY, ENGLAND, 32.33 m. Works Canada and Egypt evenings and afternoons.	7.520	RKI MOSCOW, U.S.S.R., 39.87 m. Re-lays RAN 7-9.15 pm. Works RIM early am.	6.420	HIIS SANTIAGO, D. R., 46.73 m. 11.40 am.-1.40 pm.; 5.40-7.40, 9.40-11.40 pm.
9.275	HIG CIUDAD TRUJILLO, D. R., 32.33 m. 7.10-8.40 am., 12.40-2.10, 8.10-9.40 pm.	7.510	JVP NAZAKI, JAPAN, 39.95 m. Irreg.	6.410	TIPG SAN JOSE, COSTA RICA, 46.8 m., Addr. Apartado 225, "La Voz de la Victor." 12 n.-2 pm., 6-11.30 pm.
9.200	COBX HAVANA, CUBA, 32.59 m. Addr. San Miguel 194, Altos. Relays CMBX 7 am.-12 m.	7.390	ZLT2 WELLINGTON, N. Z., 40.6 m. Works with Sydney, 3-7 am.	6.400	YV5RH CARACAS, VENEZUELA, 46.88 m. 7-11 pm.
9.170	WNA LAWRENCEVILLE, N. J., 32.72 m. Works England evenings.	7.38	XECR MEXICO CITY, MEX., 40.65 m., Addr. Foreign Office. Sun. 6-7 pm.	6.396	COX4S MARIANAO, CUBA, 46.9 m., Addr. Jefe del Cuerpo de Senales de la Republica de Cuba, Ciudad Militar, Marianao. Tests daytime and evenings.
9.150	YVR MARACAY, VENEZUELA, 32.79 m. Works with Europe afternoons.	7.220	HKE BOGOTA, COL., S. A., 41.55 m. Tues. and Sat. 8-9 pm. Mon. and Thurs. 6.30-7 pm.	6.380	H18J LA VEGA, D. R., 46.99 m. Irreg.
9.125	HAT4 BUDAPEST, HUNGARY, 32.88 m., Addr. "Radiolabor." Gyalut 22, Sun and Wed. 7-8 pm., Sat. 6-7 pm.	7.200	YNAM MANAGUA, NICARAGUA, 41.67 m. Daily at 9 pm.	6.380	YV5RF CARACAS, VENEZUELA, 47.02 m., Addr. Box 983. 6-10.30 pm.
9.095	COCA HAVANA, CUBA, 32.96 m., Addr. Galiano No. 102. Relays CMCA 9 am.-12 m.	7.100	FO8AA PAPEETE, TAHITI, 42.25 m., Addr. Radio Club Papeete. Tues. and Fri. 11 pm.-12 m.	6.360	HRPI SAN PEDRO SULA, HONDURAS, 47.19 m. 7.30-9.30 pm.
9.090	COBC HAVANA, CUBA, 32.98 m. Addr. P. O. Box 132. Relays CMBC. 6.55 am.-12.30 am.	7.090	— GUADALAJARA, JALISCO, MEX., 42.29 m., Addr. Madero 210, La Radiodifusora del Pueblo. 9-11 pm.	6.360	YVIRH MARACAIBO, VENEZUELA, 47.19 m., Addr. "Ondas Del Lago." Apartado de Correos 261. 6-7.30 am., 11 am.-2 pm., 5-11 pm.
9.060	TFK REYKJAVIK, ICELAND, 33.11 m. Works London afternoons.	7.088	PIIJ DORDRECHT, HOLLAND, 42.3 m., Addr. Dr. M. Hellingman, Technical College. Sat. 11.10-11.50 am.	6.350	HRY TEGUCIGALPA, HONDURAS, 47.24 m. 6.30-8.30 pm.
9.030	COBZ HAVANA, CUBA, 33.2 m., Radio Salas Addr. P. O. Box 866, 7:45 am.-12.10 am. Irreg. 12.30-2 am. Relays CMBZ.	6.996	PZH PARAMIRABO, DUTCH GUIANA, 42.88 m., Addr. P. O. Box 18. Daily 6.06-8.36 am., Sun. 9.36-11.36 am. Daily 5.36-8.36 pm.	6.340	HIIX CIUDAD TRUJILLO, D. R., 47.32 m. Sun. 7.40-10.40 am., daily 12.10-1.10 pm., Tues. and Fri. 8.10-10.10 pm.
9.020	GCS RUGBY, ENG., 33.26 m. Works N. Y. C. evenings.	6.977	X8A TACUBAYA, D. F., MEX., 43 m. 9.30 am.-1 pm., 7-8.30 pm.	6.330	COCW HAVANA, CUBA, 47.39 m., Addr. La Voz de las Antillas, P. O. Box 130. 6.55 am.-1 am. Sun. 10 am.-10 pm.
9.010	KEJ BOLINAS, CAL., 33.3 m. Relays NBC and CBS programs in evening irregularly.	6.976	HCETC QUITO, ECUADOR, 43 m., Addr. Teatro Bolivar. Thurs. till 9.30 pm.	6.316	HIZ CIUDAD TRUJILLO, D. R., 47.5 m. Daily except Sat. and Sun. 11.10 am.-2.25 pm., 5.10-8.40 pm. Sat. 5.10-11.10 pm. Sun. 11.40 am.-1.40 pm.
8.967	VWY KIRKÉE, INDIA, 33.43 m. Works with England in morning.	6.905	GDS RUGBY, ENG., 43.45 m. Works N.Y.C. evenings irregularly.	6.310	TG2 GUATEMALA CITY, GUAT., 47.55 m., Addr. Secretaria de Fomento. Relays TGI 11 pm.-2 am.
8.960	TPZ ALGIERS, ALGERIA, 33.48 m. Works Paris afternoons.	6.860	KEL BOLINAS, CALIF., 43.70 m. Tests irregularly. 11 am.-12n., 6-9 pm.	6.300	YV4RG MARACAY, VENEZUELA, 47.62 m. 8-10.30 pm.
8.920	COKG SANTIAGO, CUBA, 33.61 m. Addr. Box 137. 9-10 am., 11.30 am.-1.30 pm., 3-4.30, 5-6, 10-11 pm., 12 m.-2 am.	6.850	XGOX NANKING, CHINA, 43.8 m. Daily 6.40-8.40 am., Sun. 4.40-6.05 am.	6.280	COHB SANCTI SPIRITUS, CUBA, 47.77 m., Addr. P. O. Box 85. 9-11.30 am., 12.30-1.30, 4-7, 8-11 pm.
8.830	HCJB QUITO, ECUADOR, 33.95 m. 8.30-10.30 pm. except Mondav.	6.800	HI7P CIUDAD TRUJILLO, DOM. REP., 44.12 m., Addr. Emisora Diaria de Comercio. Daily exc. Sat. and Sun. 12.40-1.40, 6.40-8.40 pm. Sat. 12.40-1.40 pm. Sun. 10.40 am.-11.40 am.	6.270	YV5RP CARACAS, VENEZUELA, 47.79 m., Addr. "La Voz de la Philco." Irregular.
8.775	PNI MAKASSER, CELEBES, N. I., 34.19 m. Works Java around 4 am.	6.770	HIH SAN PEDRO DE MACORIS, DOM. REP., 44.26 m. 12.10-1.40 pm., 7.30-9 pm. Sun. 3-4 am., 4.15-6 pm., 4.40-7.40 pm.	6.243	HIN CIUDAD TRUJILLO, D. R., 48 m., Addr. "La Voz del Partido Dominicano." 12 n.-2 pm., 7.30-9.30 pm. Irregularly.
8.765	DAF NORDDEICH, GERMANY, 34.23 m. Works German ships irregularly.	6.750	WOA LAWRENCEVILLE, N. J., 44.41 m., Addr. A.T.&T. Co. Works Eng. evenings.	6.235	HRD LA CEIBA, HONDURAS, 48.12 m., Addr. "La Voz de Atlantida." 8-11 pm.; Sat. 8 pm.-1 am.; Sun. 4-6 pm.
8.760	GCQ RUGBY, ENG., 34.25 m. Works Africa afternoons.	6.750	JVT NAZAKI, JAPAN, 44.44 m., Addr. Kokusai-Denwa Kaisha, Ltd., Tokio. Irregular.	6.230	YVIRG VALERA, VENEZUELA, 48.15 m. 6-9.30 pm.
8.750	FZEB DJIBOUTI, FR. SOMALILAND, AFRICA 34.29 m. Works Paris around 2.30 am.	6.730	HI3C LA ROMANA, DOM. REP., 44.58 m., Addr. "La Voz de la Feria." 12.30-2 pm., 5-6 pm.	6.230	OAX4G LIMA, PERU, 48.15 m., Addr. Apartado 1242. Daily 7-10.30 pm.
8.730	GCI RUGBY, ENG., 34.36 m. Works India 8 am.	6.720	PMH BANDOENG, JAVA, 44.64 m. Re-lays NIRON programs. 5.30-9 am.	6.220	— SAIGON, INDO-CHINA, 48.2 m., Addr. Radio Philco. 4.30 or 5.30-9.30 am.
8.720	VPD3 SUVA, FIJI ISLES, 34 m., Addr. (See 9.540 mc., VPD2). 5.30-7 am.	6.710	TIEP SAN JOSE, COSTA RICA, 44.71 m., Addr. Apartado 257. La Voz del Tropico. Daily 7-10 pm.	6.210	YV5RI CORO, VENEZUELA, 48.31 m., Addr. Roger Leyba, care A. Urbina y Cia. Irregular.
8.700	HKV BOGOTA, COLOMBIA, 34.46 m. Tues. and Fri. 7-7.20 pm.	6.672	YVQ MARACAY, VENEZUELA, 44.95 m. Sat. 8-9 pm.	6.190	H18Q CIUDAD TRUJILLO, D. R., 48.47 m. 11.45 am.-1 pm., 4.45-6.45 pm.
8.660	GBC RUGBY, ENG., 34.56 m. Works ships irregularly.	6.670	HC2RL GUAYAQUIL, ECUADOR, S. A., 44.95 m., Addr. P. O. Box 759. Sun. 5.45-7.45 pm., Tues. 9.15-11.15 pm.	6.185	H11A SANTIAGO, D. R., 48.5 m., Addr. P. O. Box 423. 7 am.-5 pm.
8.665	COJK CAMAGUEY, CUBA, 34.64 m., Addr. Finlay No. 3 Altos. 5.30-6.30, 8-11 pm., daily except Sat. and Sun.	6.650	IAC PISA, ITALY, 45.11 m. Works ships irregularly.	6.171	XEXA MEXICO CITY, MEX., 48.61 m., Addr. Dept. of Education. 7-11 pm.
8.665	W2XGB HICKSVILLE, N. Y., 34.64 m., Addr. Press Wireless. Mon. to Fri. News at 9 am. and 5 pm.	6.630	HIT CIUDAD TRUJILLO, D. R., 45.25 m., Addr. "La Voz de la RCA Victor." Apartado 1105. Daily exc. Sun. 12.10-1.40 pm., 5.40-8.40 pm.; also Sat. 10.40 pm.-12.40 am.	6.160	YV5RD CARACAS, VENEZUELA, 48.7 m. 11 am.-2 pm., 4-10.40 pm.
8.580	YNLG MANAGUA, NICARAGUA, 34.92 m. 7.30-9.30 pm.	6.625	PRADO RIOBAMBA, ECUADOR, 45.28 m. Thurs. 9-11.45 pm.	6.160	VPB COLOMBO, CEYLON, 48.7 m. Daily exc. Thurs. and Fri., 6.30 am.-12.30 pm.; Sun. 7-11.30 am.
8.560	WOO OCEAN GATE, N. J., 35.05 m. Works ships irregularly.	6.590	COCU HAVANA, CUBA, 45.52 m., Addr. Estrada Palma 25. Vibora. Havana. Relays CMCU 7 am.-12 m.	<b>49 MET. BROADCAST BAND</b>	
8.400	HC2CW GUAYAQUIL, ECUADOR, 35.71 m. 11.30 am.-12.30 pm., 8-11 pm.	6.558	HI4D CIUDAD TRUJILLO, D. R., 45.74 m. Except Sun. 11.55 am.-1.40 pm.	6.150	ZRD DURBAN, SOUTH AFRICA, 48.78 m., Addr. (See ZRK, 9.606 mc.) Daily exc. Sat. 11.45 pm.-12.45 am.; Daily exc. Sun. 3.30-7.30 am., 9 am.-3.45 pm.; Sun. 8-11.30 am., 12 n.-3.20 pm.
8.380	IAC PISA, ITALY, 35.8 m. Works Italian ships irregularly.	6.550	X8C VERA CRUZ, MEX., 45.8 m. 8.15-9 am.	6.150	CJRO WINNIPEG, MAN., CANADA, 48.78 m., Addr. (See 11.720 mc.) 4-10 pm.
8.190	XEME MERIDA, YUCATAN, 36.63 m., Addr. Calle 59, No. 517, "La Voz de Yucatan desde Merida." 10 am.-12 n., 6 pm.-12 m.	6.550	TIRCC SAN JOSE, COSTA RICA, 45.8 m., Addr. Radioemisora Catolica Costarricense. Sun. 11 am.-2 pm., 6-7 pm., Thurs. 6-11 pm., 6-7, 8-9 pm. Daily 12 n.-2 pm.	6.147	ZEB BULAWAYO, RHODESIA, S. AFRICA, 48.8 m. Mon., Wed., and Fri. 1.15-3.15 pm.; Tues. 11 am.-12 n.; Thurs. 10 am.-12 n.
8.185	PSK RIO DE JANEIRO, BRAZIL, 36.65 m. Irregularly.	6.545	YV6RB BOLIVAR, VENEZUELA, 45.84 m., Addr. "Ecos de Orinoco." 6-10.30 pm.	6.145	HJ4ABU PEREIRA, COL., 48.8 m. 9.30 am.-12 n., 6.30-10 pm.
8.036	CNR RABAT, MOROCCO, 37.33 m. Sun. 2.30-5 pm. Irregular.	6.530	YNIGG MANAGUA, NICARAGUA, 45.94 m., Addr. "La Voz de los Lagos." 8-9 pm.	6.140	W8XK PITTSBURGH, PA., 48.86 m., Addr. Westinghouse Electric & Mfg. Co. Relays KDKA 11 pm.-1 am.
7.975	HC2TC QUITO, ECUADOR, 37.62 m. Thurs. and Sun. at 8 pm.	6.520	YY4RB VALENCIA, VENEZUELA, 46.01 m. 11 am.-2 pm., 5-10 pm.	6.137	CR7AA LAURENCO MARQUES, PORT. E. AFRICA, 48.87 m. Daily 12.05-1, 4.30-6.30, 9.30-11 am., 12.05-4 pm., Sun. 5-7 am., 10 am.-2 pm.
7.901	LSL HURLINGHAM, ARGENTINA, 37.97 m. Works Brazil at night.	6.500	HIL CIUDAD TRUJILLO, D. R., 46.15 m., Addr. Apartado 623. 12.10-1.40 pm., 5.40-7.40 pm.	(Continued on page 628)	
7.894	YSD SAN SALVADOR, EL SALVADOR, 37.99 m., Addr. Dir. Gerl. Tel. & Tel. Irregular 7-11 pm.	6.500	TIOW PUERTO LIMON, COSTA RICA, 46.15 m., Addr. Ondas del Caribe. Daily 12 n.-1.30 pm.		
7.860	SUX ABOU ZABAL, EGYPT, 38.17 m. Works with Europe. 4-6 pm.	6.490	HIIL SANTIAGO DE LOS CABALLEROS, D. R., 46.2 m., Addr. Pres., Trujillo 97, Altos., 5.40-7 pm.		
7.854	HC2JSB GUAYAQUIL, ECUADOR, 38.2 m. Evenings.				
7.797	H3P GENEVA, SWITZERLAND, 38.48 m., Addr. Radio-Nations. Sat. 5.30-6.30 pm.				
7.715	KEE BOLINAS, CAL., 38.89 m. Relays NBC and CBS programs in evening irregularly.				
7.626	RIM TACHKENT, U.S.S.R., 39.34 m. Works with Moscow in early morning.				
7.610	KWX DIXON, CAL., 39.42 m. Works with Hawaii, Philippines, Java and Japan, nights.				

All Schedules Eastern Standard Time

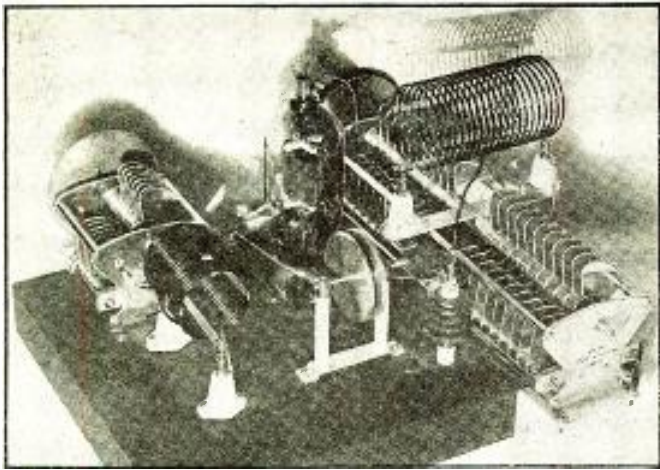

Rear view of the T-125 power amplifier.

# 300 Watts Out of a T-125



Art Gregor

An R.F. amplifier built around the new T-125 tube. Coil data is given for operation on 80, 40 and 20 meters.

● THIS three-hundred watt R.F. amplifier can be added to your present low-powered transmitter, provided its output is at least 40 watts. The unit is designed to be operated on phone or CW. The tube used is one of the new T-125's which is rated at 400 watts input (2000 volts at 200 ma.) and at 75% efficiency, 300 watts output. For operation on the three most important amateur bands—80, 40 and 20 meters it requires rather large components. The plate tank condenser especially is quite large, due to the fact that the amplifier is intended for phone operation at 2000 volts on the tube. This requires a split-stator condenser with a capacity of 100 mmf. per section and sufficient plate spacing to stand up under the strain of plate modulation at 2000 volts. The condenser has an over-all length of 14 $\frac{3}{8}$  inches behind the panel. Since the largest chassis readily obtainable has a depth of only 13 inches, it is necessary to form an L-shaped bracket to support the rear of the condenser. This is clearly shown in one of the photos, and is easily constructed of  $\frac{1}{8}$  inch aluminum stock. While this amplifier was designed for rack mounting, the panel was removed to permit clearer views of the assembly.

### How Plate Coil Is Mounted

Mounting the plate coil was quite a problem. There was hardly space for it on the chassis and even if it were placed there its field would have enveloped the other parts and caused much trouble. Finally it was mounted on the plate condenser. Due to the excellent heavy-duty construction of this particular condenser we were able to drill and tap the long horizontal frame-parts without weakening the condenser in the least. These tapped holes are drilled in the exact center of the bars and take a 6-32 machine screw. Next a piece of  $\frac{1}{8}$  inch

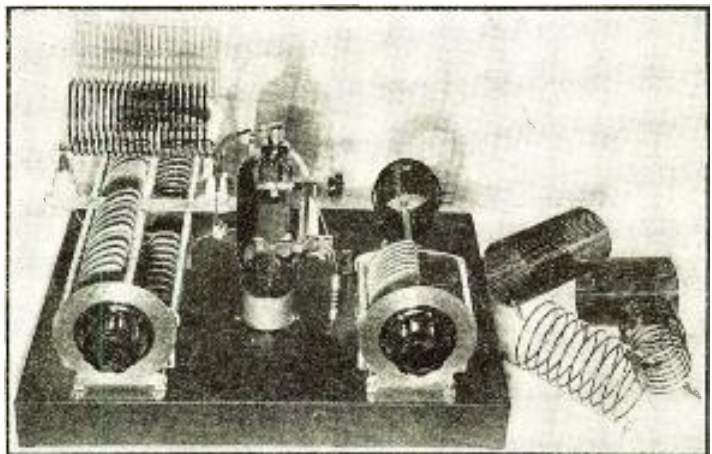

Front view of the unit.

aluminum one-inch wide and 6 $\frac{1}{2}$  inches long is arranged to fit onto the side bars and support the two stand-off insulators which are for the plug-in plate coil. This makes a convenient arrangement and will accommodate any of the standard manufactured coil assemblies, should the builder decide to buy them instead of constructing them as we have done. If a plug base is fitted to the home-made coil two or more jack type insulators can be used to facilitate coil changing. We only used two such insulators and fitted a jack on the top of the R.F. choke for the center-tap lead of the plate coil. The link which couples the amplifier to the antenna is merely wrapped around the coil and requires no terminals in the coil mounting.

Hook-up of the new amplifier, capable of developing better than 300-watts.

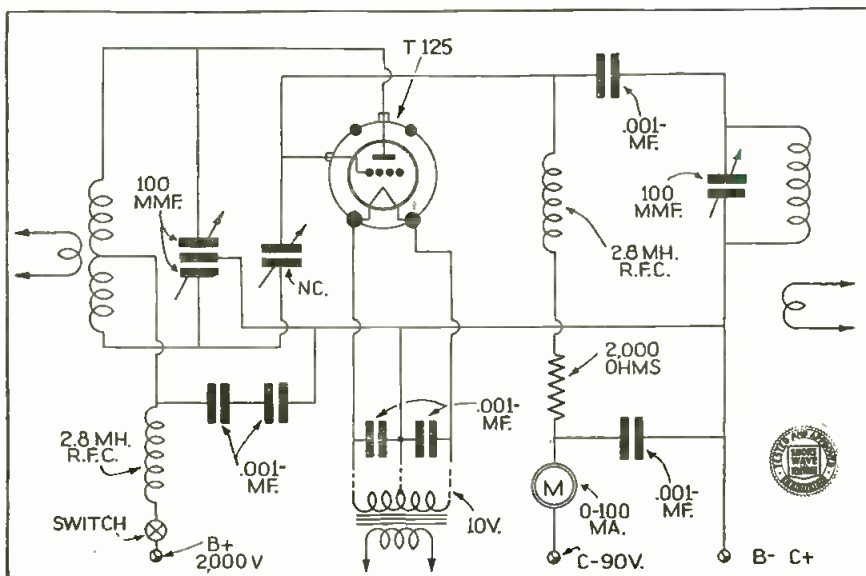

### Grid Tuning Condenser and Coil

The grid tuning condenser and the grid coil are mounted on the opposite side of the chassis with the coil facing a direction opposite that of the plate coil, in order to reduce feed-back between the input and output circuits. This makes one of the leads from the grid coil to the grid condenser rather long, around 5 inches, but that will cause much less difficulty than the feedback would. Losses in a lead this long will not affect operation of an amplifier at frequencies up to 14 mc. If operation is desired on the higher frequency bands we advise an entirely different design. This amplifier, as we said before, is only intended to operate on the 80, 40 and 20 meter bands.

Directly behind the T-125 tube is the large neutralizing condenser. This is of the disc type, designed for high voltage opera-

(Continued on page 645)

# Power-Supply and

# Modulator for

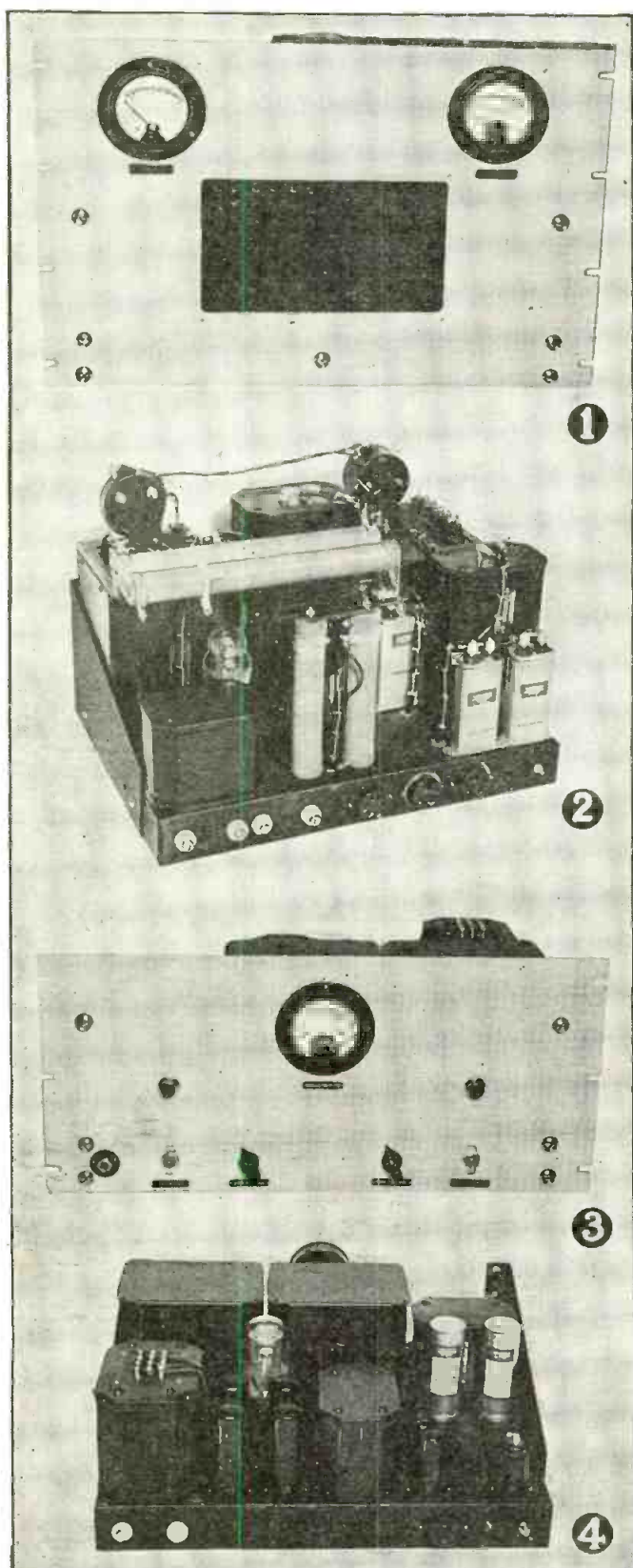

1 and 2 show front and rear views of the power-supply unit, with extra ventilating grill in center of panel. 3 and 4 show front and rear views of the modulator.

● CONSIDERABLE interest has been evinced by readers of *Short Wave and Television* in a power-supply and modulator to be used with the transmitter R.F. unit described in the October, 1937, issue of the magazine. This article will cover these additional units and the combined result will be equipment worthy of a place of prominence in any ham's shack.

Since flexibility was one of the main considerations in the design of the R.F. unit, the same theme is carried out in the equipment herein described. There are two power-supplies in the main power chassis, each of which has several values of high voltage available. Additional voltages for lower power requirements may of course be taken from the voltage dividers. A variety of filament voltages may be obtained from the transformers selected, a feature of great value to the ham.

Flexibility in the modulator is provided by multi-tapped input and output transformers which will match most any driver, modulator and P.A. tubes.

The value of the multi-sectional rack will now be seen as the new units fit onto those of the R.F. unit with no changes. If it is desired to use the transmitter for C.W. only, the complete modulator and its rack section may be omitted, but is easily added at any future time.

As in the previously described units, the present sections have panels finished in French grey paint, with black crackle finished chassis.

The units of the power supply are rather bulky and it is necessary to mount some of them in "double-decker" fashion. This is easy, however, as the units chosen are designed to make such use practical.

The voltage dividers are mounted where they will be in the clear, so that good air circulation is assured.

The high-voltage rectifiers are placed back of a grill in the panel where they will impress the uninitiated, but of more practical interest, where a good circulation of air is assured.

These rectifiers, and in fact all the other units, were chosen with a high factor of safety and, in the present set-up, are run at very conservative values. Thus, if it should be desired to jack the power up a bit nothing will be strained or overloaded.

Construction is entirely straightforward and should give no trouble. It is advisable to mount all units of the power-supply but the two power transformers, and do all wiring before they are set in place since they make the unit too heavy to handle easily. All primary and low voltage wiring is made with pushback wire of No. 14 size, while wiring to carry over 400 volts is made with heavy rubber and braid covered wire.

It will be seen from the diagram that plugs and sockets are used to connect all the units of the transmitter. This makes it possible to quickly remove any single unit without the necessity for disconnecting numerous wires. Of course, all leads carrying voltages over 400 are run separately with heavily insulated wire.

A control panel which is separate from the power supply is used and carries three switches and three pilot lamps. Further mention of this panel will be made later.

The modulator is also quite conservative in design. It has a complete built-in power-supply and is capable of an output of about 60 watts without strain. Rather than use two 6L6 tubes in the output stage and run them to the limit in class AB<sub>2</sub>, four are used in push-pull parallel, and are operated Class AB<sub>1</sub>. This method of operation allows the tubes to work well within ratings and also obviates the necessity of a separate fixed bias supply. Furthermore, very little power is required from the driver tube.

Plenty of gain is available for use with most microphones, and since the whole modulator equipment is run at conservative levels, the output quality is excellent.

The input jack and leads to the first tube control grid should be shielded, and care should be exercised in wiring grid and plate circuits of all other tubes to keep them as well separated

# H-G-M Xmitter

The Editors have received numerous requests for constructional data on a good modulator to be used with the "H-G-M Transmitter" described in the October issue of this magazine. Here is the data on such a modulator and also the power-supply.

as possible and to keep them away from filament and other leads carrying A.C.

The modulator may be tested by means of lamp or resistance loads before it is hooked in with the P.A. unit for actual transmission. A 75 to 100 watt bulb is satisfactory and its degree of brightness when compared to a similar bulb operated on the lighting circuit will give a rough measure of the modulator power output.

Close perusal of the list of parts will show that some of them are not exactly those required for the present unit. For example, the filament transformer used to supply the 7.5 volts for the RK20A has three windings, two of 2.5 volts, and one of 5 volts. In the present set-up, the 5 volt and one of the 2.5 volt windings are connected in series to supply the required 7.5 volts. This transformer was chosen with an eye to the future, however, for a coming article will carry information on the construction of a complete relay-operated control panel and remote control system, built around these parts, none of which need be discarded when the control system is built. At the same time a simple oscilloscope to be mounted on the rack will also be described. This will enable the ham to completely satisfy the requirements of Federal law stating that adequate monitoring shall at all times be employed.

This explains why seven-prong plugs are used between control panel and power chassis, as all seven are needed in the control system which has been worked out.

If such a control system is not desired, it is entirely possible

to mount the power control switches on the power unit panel and to omit the separate control panel. In this case only such rack units as needed should be procured, as the list of parts includes a rack section for the control panel.

The construction of the units described in the present article is not difficult and there are not many chances for bugs to develop if reasonable care is taken in wiring and checking. The main point is to be sure that the various voltages are correct. The high voltage to the RK20A may be 1250 for CW, but should be dropped to 1000 volts for phone. This may be done by shifting taps on the transformer. The voltage to the exciter chassis should be around 650, which is obtained by connecting the rectifier plates to the 750 volt taps. Although 650 volts is somewhat high for this use, it should be remembered that self bias is used on all tubes in this chassis, which means that much lower voltage is actually applied to the tubes.

Since results are of primary interest to prospective builders, it may be stated that although the transmitter has only been operated experimentally since the power and modulator equipment has been built, the R.F. unit has been operating on CW with temporary power equipment and has worked among others, ZL, G, GM, OZ, VE, and numerous others under rather poor operating conditions. It is expected that the new power-supply will give even better results because of the higher voltage available.

(Continued on page 646)

Below—Wiring diagrams for the power-supply and also the modulator for use with the H-G-M Transmitter.

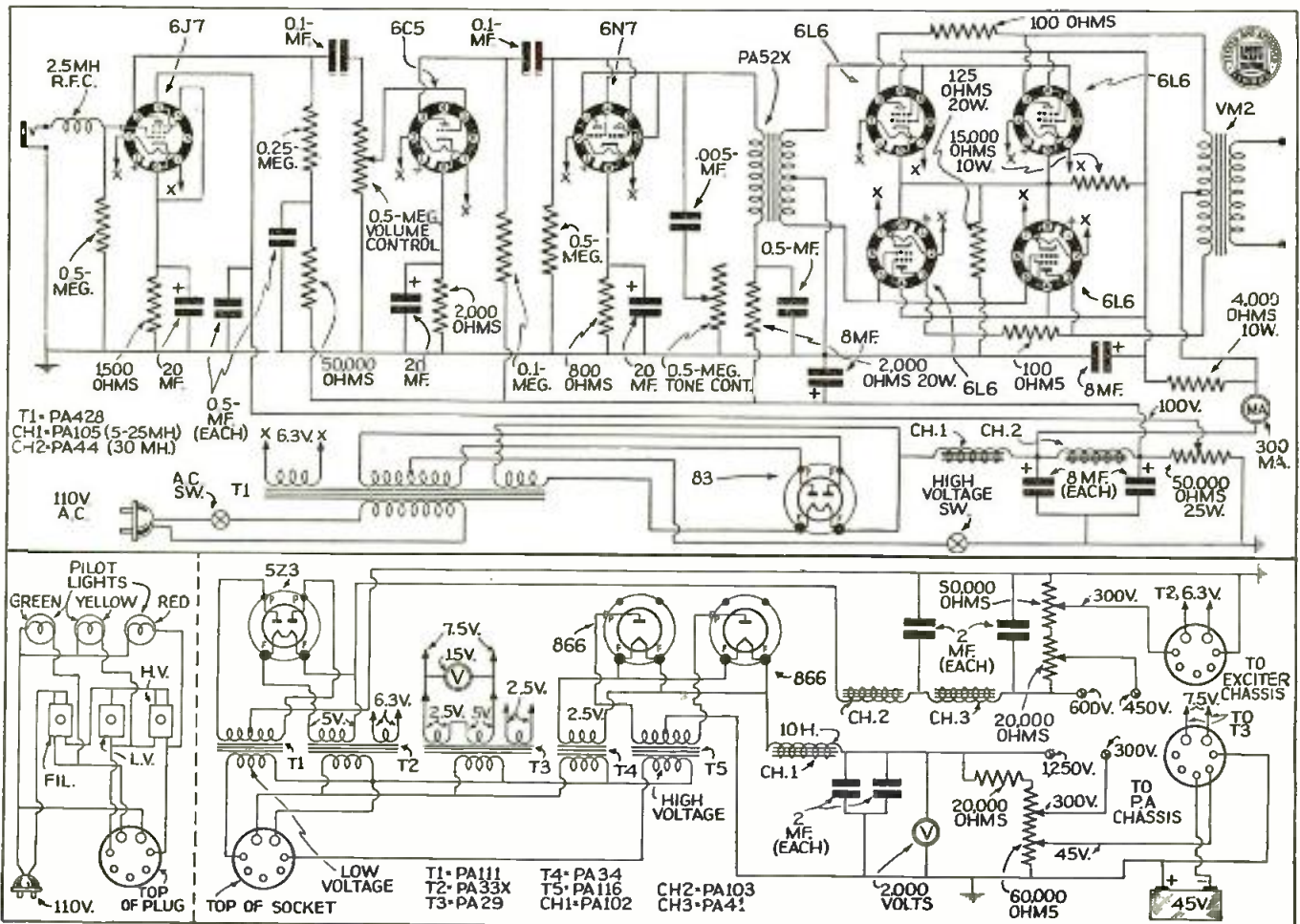

Mc. Call  
 6.135 HJ1A8B BARRANQUILLA, COL., 48.9 m.,  
 Addr. P. O. Box 715. 11.30 am.-  
 1 pm., 4.30-10 pm.  
 6.135 H15N SANTIAGO, D. R., 48.9 m. 6.40-  
 9.10 pm.  
 6.130 TGXA GUATEMALA CITY, GUAT., 48.94  
 m., Addr. Giornal Liberal Pro-  
 gressista. Irregularly.  
 6.130 VP3BG GEORGETOWN, BRIT. GUIANA.  
 48.94 m. From 5 pm. on.  
 6.130 COCD HAYANA, CUBA, 48.94 m., Addr.  
 Box 2294. Relays CMCD 7 am.-  
 1 am.  
 6.130 VE9HX HALIFAX, N. S., CAN., 48.94 m.,  
 Addr. P. O. Box 998. Mon.-Fri.  
 9 am.-1 pm., 5-11 pm. Fri. 1-3  
 pm. Sat. & Sun. 9 am.-1 pm.,  
 2-11 pm. Relays CHNS.  
 6.130 ZGE KUALA LUMPUR, FED. MALAY  
 ST., 48.94 m. Sun., Tue. and Fri.  
 6.40-8.40 am.  
 6.130 LKL JELOY, NORWAY, 48.94 m. 11 am.-  
 6 pm.  
 6.125 CXA4 MONTEVIDEO, URUGUAY, 48.98  
 m., Addr. Radio Electrico de  
 Montevideo., Mercedes 823. 10  
 am.-12 n., 2-8 pm.  
 6.125 OAXIA CHICLAYO, PERU, 48.98 m., Addr.  
 La Voz de Chiclayo, Casilla No.  
 9. 8-11 pm.  
 6.122 OAX4P HUANCAYO, PERU, 49 m. La Voz  
 del Centro del Peru, 8 pm. on.  
 6.122 HP5A PANAMA CITY, PAN., 49 m.,  
 Addr. Box 58. 12 n.-1 pm., 8-10  
 pm.  
 6.122 HJ3ABX BOGOTA, COL., 49 m., Addr. La  
 Voz de Col., Apartado 2665. 12  
 n.-2 pm., 5.30-11 pm.; Sun. 6-11  
 pm.  
 6.120 W2XE NEW YORK CITY, 49.02 m., Addr.  
 Col. 8'cast. System, 435 Madison  
 Ave. Irregular.  
 6.120 XEUZ MEXICO CITY, MEX., 49.02 m.,  
 Addr. 5 de Mayo 21. Relays  
 XEFO 1-3 am.  
 6.115 OLR2C PRAGUE, CZECHOSLOVAKIA,  
 49.05 m. (See 11.875 mc.)  
 6.110 XEPW MEXICO CITY, MEX., 49.1 m.,  
 Addr. La Voz de Aguila Azteca  
 desde Mex., Apartado 8403. Re-  
 lays XEJW 11 pm.-1 am.  
 6.110 YUC CALCUTTA, INDIA, 49.1 m. Daily  
 3-5.30 am., 9.30 am.-12 n.; Sun.  
 7.30 am.-12 n.  
 6.110 GSL DAVENTRY, ENG., 49.1 m., Addr.  
 (See 26.1 mc.) 6.20-8.30, 9.15-  
 11.15 pm., irregular.  
 6.110 YUA BELGRADE, JUGOSLAVIA, 49.1  
 m. 12.45-2.30, 4-8 am., 1-6 pm.  
 6.105 HJ4AB8 MANIZALES, COL., 49.14 m., Addr.  
 P. O. Box 175. Mon.-Fri. 12.15-  
 1 pm.; Tue. and Fri. 7.30-10 pm.;  
 Sun. 2.30-5 pm.  
 6.100 W3XAL BOUND BROOK, N. J., 49.18 m.,  
 Addr. Natl. Broad. Co. 7 pm.-  
 1 am.  
 6.100 W9XF CHICAGO, ILL., 49.18 m., Addr.  
 N.B.C. 8 am.-6.55 pm., 1.05-2 am.  
 6.100 HJ4ABE MEDELLIN, COL., 49.18 m. 11 am.-  
 12 n., 6-10.30 pm.  
 6.097 ZRK KLIPHEUVAL, S. AFRICA, 49.2 m.,  
 Daily 12 n.-4 pm., Sun. 12 n.-3.20  
 pm.  
 6.097 ZRJ JOHANNESBURG, S. AFRICA, 49.2  
 m., Addr. African Broad. Co.  
 Daily exc. Sat. 11.45 pm.-12.40  
 am.; Daily exc. Sun. 3.15-7.30,  
 9-11.30 am.  
 6.095 JZH TOKIO, JAPAN, 49.22 m., Addr.  
 (See 11.800 mc., JZJ.) Irregular.  
 6.092 OAX4Z LIMA, PERU, 49.25 m. Radio Na-  
 tional 7-11 pm.  
 6.090 HJ4ABC IBAGUE, COL., 49.26 m. 7 pm.-12  
 m.  
 6.090 CRCX TORONTO, CAN., 49.26 m., Addr.  
 Can. Broadcasting Corp. Daily  
 5.30-11.30 pm.; Sun. 5-11.30 pm.  
 6.090 XEBF JALAPA, MEXICO, 49.26 m., Addr.  
 Insurgentes 34. Testing.  
 6.090 ZBW2 HONGKONG, CHINA, 49.26 m.,  
 Addr. P. O. Box 200. Irregular.  
 6.085 HJ5ABD CALI, COLOMBIA, 49.3 m., Addr.  
 La Voz de Valle. 12 n.-1.30 pm.,  
 5.10-9.40 pm.  
 6.083 VQ7LO NAIROBI, KENYA, AFRICA, 49.31  
 m., Addr. Cable and Wireless,  
 Ltd. Mon., Fri. 5.30-6 am., 11.15  
 am.-2.15 pm., also Tues. and  
 Thurs. 8.15-9.15 am.; Sat. 11.15  
 am.-3.15 pm.; Sun. 10.45 am.-  
 1.45 pm.  
 6.080 ZHJ PENANG, FED. MALAY STATES,  
 49.34 m. 6.40-8.40 am., except  
 Sun., also Sat. 11 pm.-1 am.  
 6.080 W9XAA CHICAGO, ILL., 49.34 m., Addr.  
 Chicago Fed. of Labor. Relays  
 WCFL irregular.  
 6.079 DJM BERLIN, GERMANY, 49.34 m.,  
 Addr., Broadcasting House. Ir-  
 regular.  
 6.070 VP3MR GEORGETOWN, BRIT. GUIANA,  
 49.42 m. Sun. 7.45-10.15 am.;  
 Daily 4.45-8.45 pm.

Mc. Call  
 6.070 HJ3ABF BOGOTA, COL., 49.42 m. 7-11.15  
 pm.  
 6.070 CFRX TORONTO, CAN., 49.42 m. Relays  
 CFR8 6.30 am.-11 pm. Sun. 9.30  
 am.-11 pm.  
 6.070 YVIRE MARACAIBO, VEN., 49.42 m. 6-11  
 pm.  
 6.070 VE9CS VANCOUVER, B. C., CAN., 49.42  
 m. Sun. 1.45-9 pm., 10.30 pm.-  
 1 am.; Tues. 6-7.30 pm., 11.30  
 pm.-1.30 am. Daily 6-7.30 pm.  
 6.069 — TANANARIVE, MADAGASCAR,  
 49.42 m., Addr. (See 9.53 mc.)  
 12.30-12.45, 3.30-4.30, 10-11 am.,  
 Sun. 2.30-4.30 am.  
 6.065 HJ4A8L MANIZALES, COL., 49.46 m. Daily  
 11 am.-12 n., 5.30-7.30 pm.; Sat.  
 5.30-10.30 pm.  
 6.065 S8G MOTALA, SWEDEN, 49.46 m. Re-  
 lays Stockholm 1.30-5 pm.  
 6.060 W8XAL CINCINNATI, OHIO, 49.5 m.,  
 Addr. Crosley Radio Corp. Re-  
 lays WLW 6.30 am.-8 pm., 11  
 pm.-2 am.  
 6.060 W3XAU PHILADELPHIA, PA., 49.5 m. Re-  
 lays WCAU 8-11 pm.  
 6.050 HP5F COLON, PAN., 49.59 m., Addr.  
 Carlton Hotel. 11.45 am.-1.15  
 pm., 7.45-10 pm.  
 6.050 GSA DAVENTRY, ENGLAND, 49.59 m.,  
 Addr. (See 26.1 mc.) 12.20-4 pm.  
 Irregular.  
 6.045 H19B SANTIAGO, D. R., 49.63 m. Irregu-  
 lar 6-11 pm.  
 6.042 HJ1ABG BARRANQUILLA, COL., 49.65 m.,  
 Addr. Emisora Atlantico, 11 am.-  
 11 pm.; Sun. 11 am.-8 pm.  
 6.040 W4XB MIAMI BEACH, FLA., 49.65 m.,  
 Relays WIOD 12n.-2 pm., 5.30-6  
 pm., 10 pm.-12 m.  
 6.040 WIXAL BOSTON, MASS., 49.65 m., Addr.  
 University Club. Exc. Sat. 7-9 pm.  
 6.040 YDA TANDJONGPRIOK, JAVA, 49.65  
 m., Addr. N.I.R.O.M., Batavia,  
 10.30 pm.-2 am.; Sat. 7.30 pm.-  
 2 am.  
 6.030 HJ4ABP MEDELLIN, COL., 49.75 m. 8-11  
 pm.  
 6.030 HP5B PANAMA CITY, PAN., 49.75 m.,  
 Addr. P. O. Box 910. 12 n.-1 pm.,  
 7-10.30 pm.  
 6.030 VE9CA CALGARY, ALTA, CAN., 49.75 m.  
 Thur. 9 am.-2 am.; Sun 12 n.-  
 12 m.  
 6.030 OLR2B PRAGUE, CZECHOSLOVAKIA,  
 49.75 m. (See 11.875 mc.) Daily  
 12.45-4.40 pm. Mon., Wed. and  
 Fri. 8-10.35 pm.  
 6.025 HJ1ABJ SANTA MARTA, COL., 49.79 m.  
 11.30 am.-2 pm., 5.30-10.30 pm.  
 except Wed.  
 6.020 DJC BERLIN, GERMANY, 49.83 m.,  
 Addr. (See 6.079 mc.) 10.40 am.-  
 4.30, 4.50-10.45 pm.  
 6.020 XEUW VERA CRUZ, MEX., 49.83 m., Addr.  
 Av. Independencia 98. 8 pm.-  
 12.30 am.  
 6.018 ZHI SINGAPORE, MALAYA, 49.84 m.,  
 Addr. Radio Service Co., 2  
 Orchard Rd. Mon., Wed. and  
 Thur 5.40-8 am., Sat. 10.40 pm.-  
 1.10 am.  
 6.015 H13U SANTIAGO DE LOS CABALLEROS  
 D. R., 49.88 m. 7.30-9 am., 12 n.-  
 2 pm., 5-7 pm., 8-9.30 pm.; Sun.  
 12.30-2, 5-6 pm.  
 6.010 COCO HAYANA, CUBA, 49.92 m., Addr.  
 P. O. Box 98. Daily 7.55 am.-  
 12 m., Sun. 11 pm.  
 6.010 PRA8 PERNAMBUCO, BRAZIL, 49.92 m.,  
 Radio Club of Pernambuco, 6-9  
 pm.  
 6.010 9MI S. S. KANIMBLA, 49.92 m. (Travels  
 between Australia and New Zea-  
 land). Sun. around 7 am.  
 6.010 CJCX SYDNEY, NOVA SCOTIA, 49.92 m.  
 Relays CJC8 7 am.-1 pm., 4-8 pm.  
 6.007 ZRH ROBERTS HEIGHTS, S. AFRICA,  
 49.94 m., Addr. (See ZRK, 9.606  
 mc.) Daily exc. Sun. 10 am.-4  
 pm., Sat. 11.45 pm.; Sun. 8  
 am.-12 n., 12.15-3.15 pm.  
 6.005 HP5K COLON, PAN., 49.96 m., Addr.  
 Box 33. 7-9 am., 11.30 am.-1 pm.,  
 6-11 pm.  
 6.005 CFCX MONTREAL, CAN., 49.96 m. Can.  
 Marconi Co. Relays CFCF 7.45  
 am.-1 am.; Sun. 10 am.-12.15 am.  
 6.005 VE9DN DRUMMONDVILLE, QUE., CAN.,  
 49.96 m., Addr. Canadian Mar-  
 coní Co. Sat. 11.30 pm.-2 am.  
 6.000 CXA2 MONTEVIDEO, URUGUAY, 50 m.,  
 Addr. Rio Negro 1631. Relays  
 LS2, Radio Prievo, Buenos Aires.  
 10.30 am.-10.30 pm.  
 6.000 ZEA SALISBURY, RHODESIA, S. AFRICA,  
 50 m. (See 6.147 mc., ZEB.) Also  
 Sun. 3.30-5 am.  
 6.000 RV59 MOSCOW, U.S.S.R., 50 m. Irregular.  
 3-6 pm.  
 5.990 XEBT MEXICO CITY, MEX., 50.08 m.,  
 Addr. P. O. Box 79.44. 8 am.-1  
 am.

Mc. Call  
 5.977 CS2WD LISBON, PORTUGAL, 50.15 m.,  
 Addr. Rua Capelo 5. 3.30-6 pm.  
 5.970 HJ4ABD MEDELLIN, COL., 50.26 m., Addr.  
 La Voz Catia. 8-11.30 pm.  
 5.968 HVJ VATICAN CITY, 50.27 m. 2-2.15 pm.  
 daily; Sun. 5-5.30 am.  
 5.950 HJN BOGOTA, COL., Radiodifusora  
 Nacional 50.42 m. 6-11 pm.  
 5.940 TG2X GUATEMALA CITY, GUAT., 50.5  
 m. 4-6, 9-11 pm.; Sun. 2-5 am.  
 5.930 YVIRL MARACAIBO, VEN., 50.59 m.,  
 Addr. Radio Popular, Jose A.  
 Higuera M., P. O. Box 247. Daily  
 11.43 am.-1.43 pm., 5.13-10.13  
 pm.; Sun. 9.13 am.-3.13 pm.  
 5.925 HH2S PORT-AU-PRINCE, HAITI, 50.63  
 m., Addr. P. O. Box A103. 7-9.45  
 pm.  
 5.917 YV4RP VALENCIA, VEN., 50.71 m. Irreg.  
 5.900 ZN8 MAFEKING, BRI. BECHUANA-  
 LAND S. AFRICA, 50.84 m. Addr.  
 The Govt. Engineer, P. O. Box  
 106. Gives news Sun. at 1.30 pm.  
 5.900 TMS PUNTARENAS, COSTA RICA,  
 50.85 m. 6-10 pm.  
 5.898 YV3RA BARQUISIMETO, VEN., 50.86 m.,  
 Addr. La Voz de Lara, 12 n.-1  
 pm., 6-10 pm.  
 5.890 JIC TAIHOKU, FORMOSA, 50.93 m.  
 Works Tokio 6-9 am.  
 5.885 HCK QUITO, ECUADOR, 50.98 m. 8-11  
 pm.  
 5.875 HRN TEGUCIGALPA, HONDURAS, 51.06  
 m. 1.15-2.16, 8.30-10 pm.; Sun  
 3.30-5.30, 8.30-9.30 pm.  
 5.855 HIJ SAN PEDRO DE MACORIS, D. R.,  
 51.25 m., Addr. Box 204. 12 n.-  
 2 pm., 6.30-9 pm.  
 5.853 W08 LAWRENCEVILLE, N. J., 51.26 m.,  
 Addr. A.T.&T. Co. Works Ber-  
 muda nights.  
 5.850 YVIR8 MARACAIBO, VEN., 51.28 m.,  
 Addr. Apartado 214. 8.45-9.45  
 am., 11.15 am.-12.15 am., 4.45-  
 9.45 pm.; Sun. 11.45 am.-12.45  
 pm.  
 5.830 TDD SHINKYO, MANCHUKUO, 51.46  
 m. Works Tokio 6-9 am.  
 5.830 TIGPH SAN JOSE, COSTA RICA, 51.5 m.,  
 Addr. Alma Tica, Apartado 800.  
 11 am.-1 pm., 6-10 pm. Relays  
 TIX 9-10 pm.  
 5.813 TI2H SAN JOSE, COSTA RICA, 51.59  
 m., Addr. Senor Gonzalo Pinto,  
 H.  
 5.800 YV5RC CARACAS, VEN., 51.72 m., Addr.  
 Radio Caracas. Sun. 8.30 am.-  
 10.30 pm. Daily 7-8 am., 10.30  
 am.-1.45 pm., 3.45-9.30 pm.  
 5.790 JVU NAZAKI, JAPAN, 51.81 m. Irreg.  
 5.780 OAX4D LIMA, PERU, 51.9 m., Addr. P. O.  
 Box 853. Mon., Wed. and Sat.  
 9-11.30 pm.  
 5.770 YV2RA SAN CRISTOBAL, VENEZUELA,  
 51.96 m., Addr. La Voz de  
 Tachira. 11.30 am.-12 n., 5.30-9  
 pm., Sun. 11 pm.  
 5.758 YNOP MANAGUA, NICARAGUA, 52.11  
 m. 8-9.30 pm.  
 5.740 TGS GUATEMALA CITY, GUAT., 52.26  
 m. Wed., Thur. and Sun. 6-9 pm.  
 5.730 HCIPM QUITO, ECUADOR, 52.36 m. Ir-  
 regular 10 pm.-12 m.  
 5.500 TISHH SAN RAMON, COSTA RICA, 54.55  
 m. Irregular 3.30-4, 8-11.30 pm.  
 5.145 PMY BANDOENG, JAVA, 58.31 m. 5.30-  
 11 am.  
 5.077 WCN LAWRENCEVILLE, N. J., 59.7 m.  
 Addr. A.T.&T. Co. Works England  
 late at night irregularly.  
 5.025 ZFA HAMILTON, BERMUDA, 59.7 m.  
 Works N.Y.C. irregularly at night.  
 5.000 TFL REYKJAVIK, ICELAND, 60 m.  
 Works Europe nighttime irreg.  
 4.975 G8C RUGBY, ENG., 60.3 m. Works ships  
 irregularly.  
 4.900 HJ3ABH BOGOTA, COL., 61.19 m., Addr.  
 Apartado 565. 12 n.-2 pm., 6-11  
 pm.; Sun. 12 n.-2 pm., 4-11 pm.  
 4.836 HJ3ABD BOGOTA, COL., 62 m., Addr. La  
 Nueva Granada, Box 509. 12 n.-  
 2 pm., 7-11 pm., Sun. 5-9 pm.  
 4.820 GDW RUGBY, ENG., 62.24 m. Works  
 N.Y.C. nighttime irregularly.  
 4.810 HJ2ABC CUCUTA, COL., 62.34 m. La Voz  
 de Cucuta, 8 pm. to 12 m.  
 4.807 HJ1A88 BARRANQUILLA, COL., 62.39 m.,  
 La Voz de Barranquilla, Addr.  
 P. O. Box 715. 11.30 am. to 1  
 pm., 4.30-6 pm.  
 4.752 WOO OCEAN GATE, N. J., 63.1 m.,  
 Addr. A. T. & T. Co. Works ships  
 irregularly.  
 4.600 HC2ET GUAYAQUIL, ECUADOR, 65.22 m.  
 Addr. Apartado 249. Wed. and  
 Sat. 9.15-11 pm.  
 4.272 WOO OCEAN GATE, N. J., 70.22 m.  
 Addr. A.T.&T. Co. Works ships  
 irregularly.  
 4.250 RV15 KHABAROVSK SIBERIA, U.S.S.R.,  
 70.42 m. 1-10 am.

All Schedules Eastern Standard Time

# Simple Laboratory Practices for Beginners

Jim Kirk, W6DEG

## Helpful Hints in Planning, Preparing Chassis and Panel, Wiring and Testing

● **BEFORE** beginning any experiments, before starting to build any apparatus, there should be diagrams and plans. Some one said, long ago, *Plan your work and then work your plan.*

That is exceptionally good advice. If a builder of houses worked like some radio experimenters work we should see him tacking together odd pieces of lumber, any size handy and without any plan and with just a pious hope they would fit. The finished result could not avoid being cock-eyed, fail to give any service and would probably fall to pieces in the first bad weather.

**Sketches:** You should have, first of all, a loose-leaf notebook or a scratch pad for temporary pencil sketches. A useful kink to employ as an aid to wiring is to have a pencil sketch of the diagram and fill in the lines with red pencil as you wire. Thus, you will be sure not to neglect any wires and you can see at a glance just how much more wiring needs to be done.

**Learn Symbols:** You ought to learn the symbols representing radio parts. They are not difficult to learn and it is much simpler and easier to draw schematic diagrams than pictorial ones. The former are easier to read, too.

### Making Diagrams Easier to Read

In drawing diagrams, you should aim to make them easy to follow for constructional or service purposes. One great aid in

reading wiring diagrams is the use of colored pencils, a different color for each part of the circuit. Then, instead of being forced to follow with a pencil through a maze of connections, your eye will instantly tell you where the wire begins and ends.

The following tricks and short-cuts are helpful: First, avoid showing wires crossing as much as possible. There are two methods of showing wires crossing without connecting—one is to use a little loop and the other is to simply cross them and put a dot where they touch if there is a connection. But either method is apt to cause confusion if used too often, so avoid crossing diagram wires, as much as possible. You will find you can do this by placing parts where they naturally connect into each other.

If many wires are shown running side by side for any distance—separate them *uneven* distances. They are easier to follow with the eye than many parallel wires separated even distances.

Use arrows for filament wiring and other wiring, too, if the diagram is very complicated. Use the ground symbol whenever a wire is to be grounded to chassis instead

(Continued on page 639)

Diagrams at the right show radio symbols; simple tests for "shorted" condenser and "open" resistor; also how to cable wires. Diagram below shows "difficult-to-read" diagram at left, and at right same diagram drawn in usual "easy-to-read" style.

**RESISTOR** **VAR. RES.** **TRIODES**

**COIL** **CHOKES** **TETRODE** **PENTODE**

**POTEN.** **CONDENSER** **PENTODE** **RECTIFIER**

**VAR. COND.** **TRANSF.** **TYPICAL TUBE SYMBOLS**

**JACK**

**TEST FOR SHORTED FILTER CONDENSER**

IF OPENING THIS OR LEAD X2 CAUSES RED PLATE IN RECT. TUBE TO DISAPPEAR, "SHORTED" COND. IS THUS INDICATED

**SUSPECTED "OPEN" RESISTOR**

**NEW "TEST" RESISTOR** WHEN SHUNTED ACROSS OPEN RESISTOR WILL CAUSE SET TO PLAY O.K.

**TESTING FOR "OPEN" RESISTOR**

**LAYOUT OF PANEL DRAWN ON PAPER AND PASTED ON PANEL**

**HOW TO DRILL PANELS WITHOUT SCRATCHING**

**BURLAP NEEDLE** **FINISH**

**TIE** **START** **TIE**

**START** **TIE**

**SINGLE CORD LOCK STITCH** **DOUBLE CORD LOCK STITCH**

**CONNECTION BLOCK** **NAILS**

**CABLE BOARD LAYOUT** **CABLE**

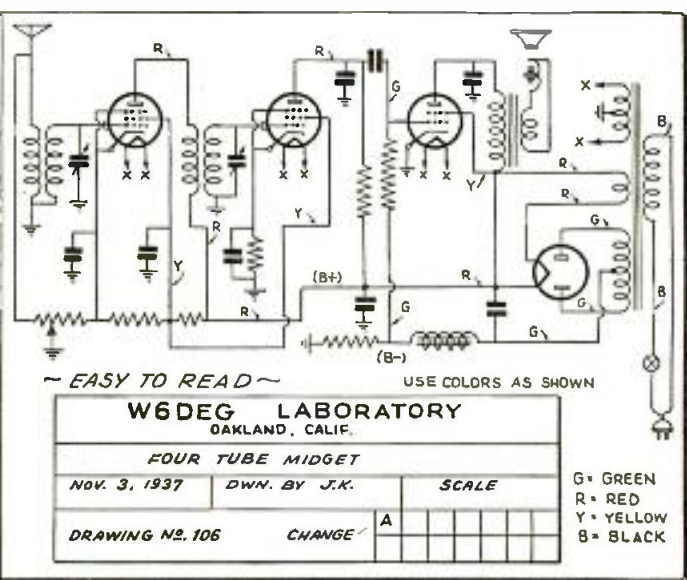
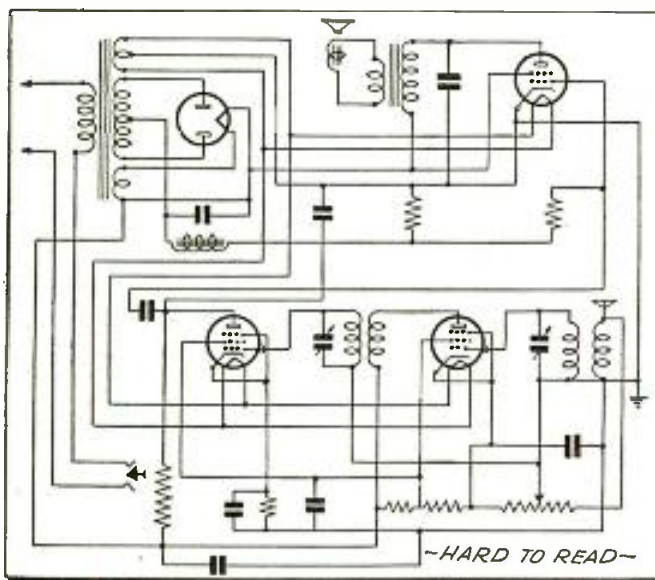

# CBS Station W2XE In Action!

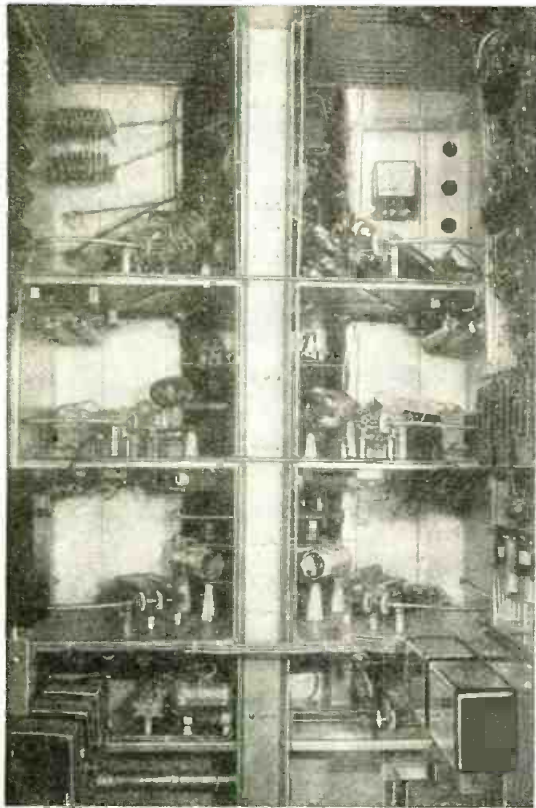

Rear view of exciter unit. Close-up, showing crystal oscillator, buffer and frequency doubling stages.

● WATER-COOLED high-frequency tubes, shown in the accompanying photos and diagrams, help to improve the efficiency of CBS's short-wave transmitter located at Wayne, N. J. One of the newest inventions in radio broadcasting, the automatic peak volume-limiter is incorporated in the circuit of the transmitter, to prevent undesirable peaks (overmodulation) in the wave radiated, so far as the tone or voice quality is concerned.

It might be explained that starting a 3 H.P. motor sets the water pump and blower or cooling fan in operation; see drawing below. The former forces the water through the copper pipes to the water cooler and thence to the water-cooled tubes in the transmitter. After passing through the water jacket and around the anodes, the water returns to the storage tank, and goes through the pump and cooler again.

As a rule, the water (Continued on page 644)

The accompanying photos and diagrams show how water cools the high frequency tubes used at W2XE. An automatic peak volume-limiter is also employed.

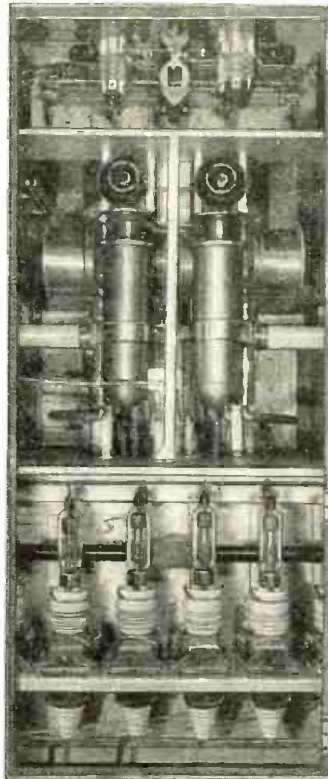

Front view (door open), showing speech amplifier and water-cooled tubes used in class B modulator.

10 kw. S-W transmitter. Front view, showing neutralizing condensers and water-cooled tubes.

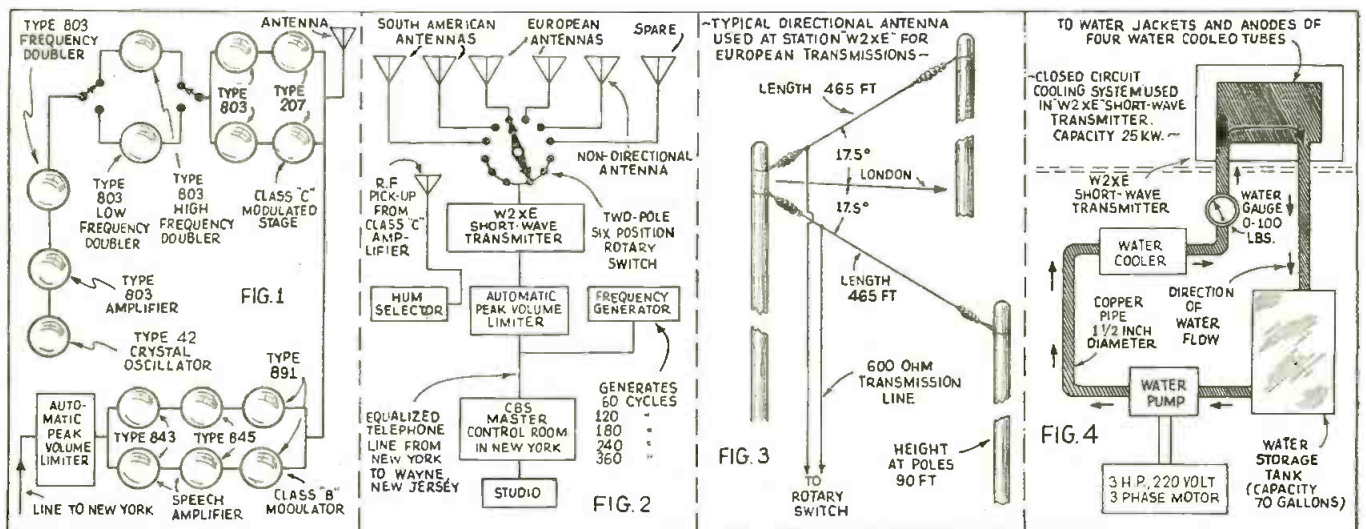
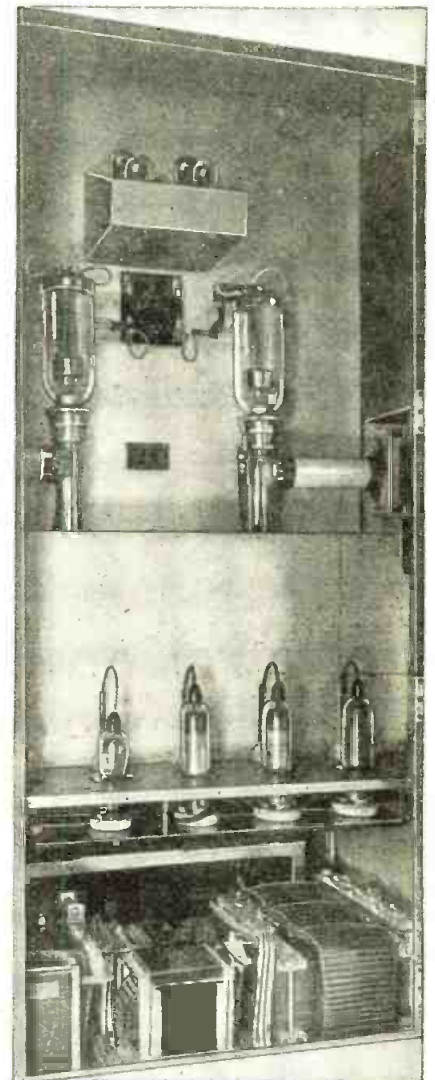
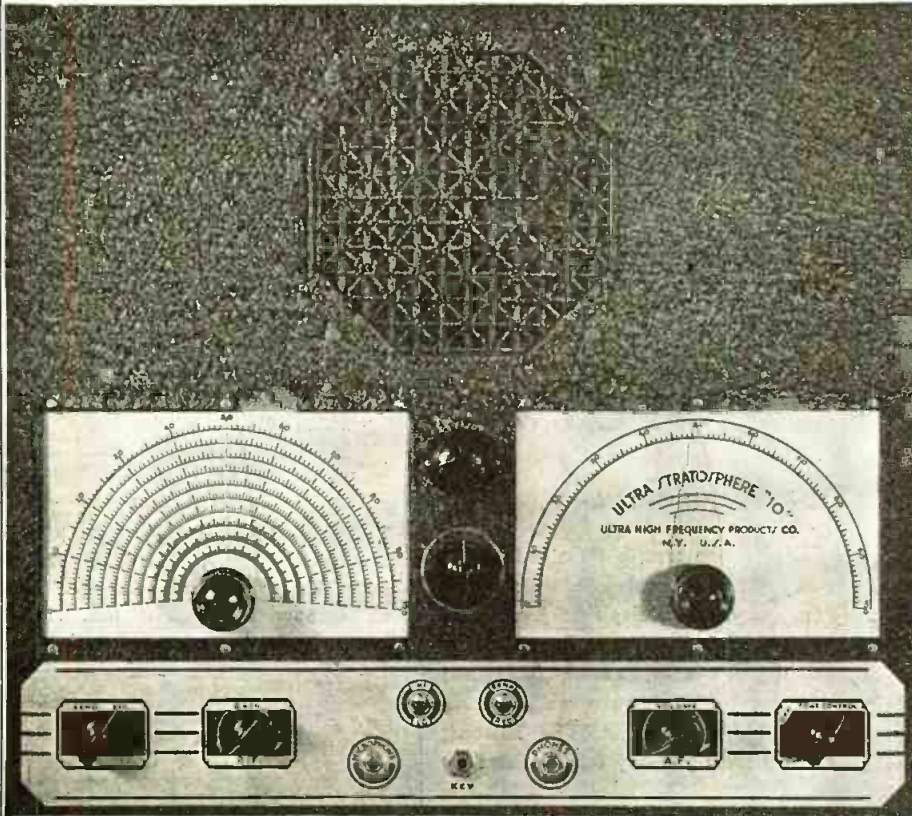

Fig. 1—block diagram of tube line-up of the W2XE S-W transmitter. Fig. 2—circuit position of new automatic "peak volume-limiter." Fig. 3—typical S-W antenna used at W2XE for directional broadcasting to Europe on 15270 and 21520 kc. Fig. 4 shows water cooling system for high frequency tubes.



# THE NEW 1938 ULTRA STRATOSPHERE "10"

## 2½ to 4000 METER TRANS-RECEIVER (RECEIVES 2½ to 4000 METERS TRANSMITS 2½ and 5 METERS)



- \*Ten tubes.
- 1—6K7 Regenerative Tuned R.F. Amplifier.
- 1—6J7 Regenerative Detector.
- 1—6J5G Super Regenerative Detector & Transmitting Osc.
- 2—6C5 P.P. 1st Audio Stage.
- 2—25L6 P.P. Beam power output stage & modulators.
- 2—25Z6 Parallel Rectifiers.
- 1—6G5 Electronic tuning indicator & R meter.
- \*Receives from 2½ to 4000 meters.
- \*Transmits on 2½ & 5 meters.
- \*8" Dynamic Speaker.
- \*Calibrated R.F. Gain Control.
- \*A.P. Gain Control.
- \*Size—17½" x 19½"—16 gauge metal.
- \*Tone control.
- \*R.F. Resonator control.
- \*Separate electrical bandspread.
- \*Vernier planetary drives on tuning Cond.
- \*Large 8" tuning dials.
- \*May be used for I.C.W. and phone transmission and as a code practice oscillator. Only a key required.
- \*Standby switch.
- \*Automatic Phone jack.
- \*Built-in A.C. & D.C. Power supply.

Complete kit of parts, including 8" Dynamic Speaker, unwired, less tubes and accessories **\$18.95**

1 Kit of 10 matched Sylvania tubes.....\$6.95  
 Set of 4 coils—2½ to 15 meters..... .30  
 Set of 8 coils—15 to 550 meters..... 2.20  
 Set of 4 coils—550 to 4000 meters..... 2.00  
 American S. B. Hand-mike..... 2.95  
 Wired and tested extra..... 4.50

### SENSATIONAL ULTRA A. C. + D. C. 2-TUBE TRANS-RECEIVERS 2½ to 4000 Meters

#### TRULY A SENSATION

Uses the new 6J5G super triode tube which is the equivalent of acorn types

Never before was a unit of this type available at any price. This compact and self-contained unit will receive from 2½ to 4000 meters with a high degree of excellence. Will receive foreign stations, amateurs, police calls, broadcast, press, airplane and weather reports, time signals, and all ultra high frequency stations. As a 2½ and 5 meter transmitter surprising results will be obtained when calling friends from afar.

- FEATURES**
- Transmits from 2½ to 5 meters
  - Receives from 2½ to 4000 meters (32 bands)
  - Separate electrical and mechanical bandspread
  - Loud speaker volume
  - Automatic super-regeneration, 2½ to 15 meters
  - House to house communication
  - Plate modulation
  - Built-in A.C. & D.C. power supply (any cycle)
- |   |               |
|---|---------------|
| Complete kit unwired less tubes, coil, cabinet, microphone..... | <b>\$7.15</b> |
| Cabinet.....  | .95           |
| Matched set of tubes (12A7-6J5G).....                           | 1.65          |
| Wired and tested.....   | 2.00          |
| Set of 4 coils (2½ to 15 meters).....                           | .30           |
| Set of 4 coils (15 to 200 meters).....                          | .95           |
| Set of 5 coils (200 to 4000 meters).....                        | 2.75          |
| American S.B. Hand-mike.....                                    | 2.95          |
| 5" Magnetic Speaker.....  | 1.25          |

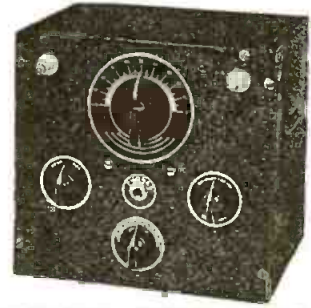

Complete, wired and tested with Sylvania 523 rectifier tube and cabinet **\$4.95**

### SPECIAL HEAVY DUTY POWER SUPPLY

#### OUTSTANDING FEATURES

- 6.3 volts at 6 amps.
- 400 volts D.C. at 250 mils.
- Encased in handsome black crackle metal finish cabinet 12¼"x7½"x3½" overall dimensions.
- Tapped extremely heavy duty power transformer allows operation on any line voltage from 95 to 250 volts, 25 or 60 cycles.
- Ideal for medium powered transmitter or P.P. 6L6 amplifier or modulator.

**ULTRA HIGH FREQUENCY PRODUCTS CO.,** 123 Liberty St. New York, N.Y.

Act now as quantity is limited

## Short Waves Guide Planes Between Europe and South America

(Continued from page 601)

This seems quite an effort considering the fact that the number of planes rarely exceeds one a day, but one must consider that of the two radio operators only one does regular service. The other takes care of the homing devices and direction finders, of which two complete outfits have been installed.

So much for the radio station. As the map indicates, the planes do not make the flight from Europe to South America all in one hop. The reason for this division into three stop-overs as shown in Fig. 1 is simple. The route extends over thousands of miles, and a reasonable formula had to be found between *pay-load* and *fuel weight* to make this service reasonably economical.

Besides, airplanes of the design required to make non-stop trips of this type are not available.

These restrictions led automatically to the stop at the Azores, and the two refueling stations in mid-ocean. Of course starting and landing at the *floating islands* is not as easy as at the Azores. Nevertheless, by means of an ingeniously designed crane, installed astern on the *Friesenland*, the plane is fastened to a line and hoisted aboard.

The lines are operated by a mechanism which causes them to rise and fall in the same tempo as the seas, giving the crew of the plane a chance to fasten the tackle without being jerked into the water, and without any risk to the plane.

After refueling the plane, and providing the crew with a good meal and sleep, it is set on a catapult device, which resembles an air-pressure gun in principle. The ship turns its stern into the wind. The pilot opens the throttle, the catapult engineer throws open the valves, and instantly the plane is off with an acceleration of approximately 70-80 miles an hour. The smell of burning oil and the sound of the escaping air is all that remains. All mechanical contact between steamer and plane has ended. But up to the minute the plane lands on either continent, radio waves keep up another type of contact by means of which accurate *direction* and *weather reports* are placed at the instant disposal of the pilot.

Please mention SHORT WAVE & TELEVISION when writing advertisers

# Short Wave

## The Forty-Seventh Trophy

Presented to SHORT WAVE SCOUT

JACK STALEY

3223 N. E. 69th Avenue

Portland, Oregon

For his contribution toward the advancement of the art of Radio

by

SHORT WAVE and TELEVISION

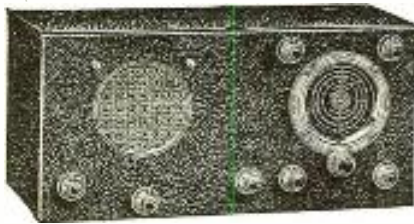

### DOERLE MODEL D-38

A. C. 17½ x 8½ x 8½

8 Tubes 4½ to 3000 Meters

The last word in short wave receivers. Before you buy send for circular D-38, an eight-page booklet containing schematic and picture diagrams, instructions, and sketches.

Read this booklet and compare with the other models you have in mind. Then send your order to the concern who in your opinion is giving you the best for your money.

Complete, with all coils, and tubes \$32.50  
no extras.....

Kit, factory assembled, but unwired, less tubes, with all coils.... \$22.50

### 7C 5-Tube

Short Wave Receiver 8¼ to 625 Meters



**Bigger and More Powerful Than Ever A Giant in Performance**

Uses a 6K7 radio-frequency stage, a 6F7, twin 2 in 1 tube, as regenerative detector and first audio, one 6C5, one 12A7, twin 2 in 1 tube, and one K92A. Earphone hook has been incorporated to permit the use of phone when loudspeaker operation is not desired. Operates from regular house current.

Size: 10x7½x7½.  
Complete with all coils, 9¼ to 600 meters, and all tubes, ready to use, nothing else to buy,....\$16.50  
In kit form, but factory assembled, including all coils and tubes, but unwired.....\$12.95

\*Available in battery model upon special order at same price.

\*\*Also available in ham model with special tuning circuit to provide additional bandspread at \$1.00 additional.

### 2-Tube Electric Set



Complete with 5 coils, 2 tubes, wired and tested, 12 to 800 meters, which includes the broadcast band,....\$4.00  
In kit form, factory assembled with coils, but less tubes and unwired.....\$2.50  
Available for battery operation at the same price, if specified.

## FLASH!

JUST OFF THE PRESS!

SEND FOR OUR NEW CATALOG containing CIRCUIT DIAGRAMS, and complete information on over 25 different types of short wave receivers and transmitters from \$2.50 and up.

This catalog is chock full of schematic and picture diagrams, hook ups and short wave information. A book in itself. Well worth the dime, which is refunded when you send your order.

**OSCAR B. USTERMAN**  
68 Barclay Street, New York City

### First World-Wide Contest Won With 6 Veris

● DESPITE the fact that the contest for this month was world-wide, we received only one entry. Mr. Staley's entry consisted of twelve cards. Six of these, however, did not fall within the rules of the contest and were disqualified so that the remaining six won the trophy for him. The listening period was from January 8th to February 2, 1937.

It was rather surprising that more entries were not received, particularly since the World-Wide type of contest allows more leeway for contestants in selection of cards.

We can only ascribe a lack of competition to the many distractions at holiday time. Our felicitations to the winner.

The receiver used was an 8-tube Brown-ing together with a 40 ft. inverted L antenna; no ground was used.

### List of Stations

3LR, 9.5 mc., Melbourne, Australia XEBT, 6. mc., Mexico City, Mexico RNE, 12. mc., Moscow, U.S.S.R. HC2RL, 6.67 mc., Guay-aquil, Ecuador FO8AA, 7.1 mc., Papeete, Tahiti W8XAL, 6.06 mc., Cincinnati, Ohio.



George D. Sallade, Sinking Spring, Pa., one of the previous trophy winners.

## Second World-Wide Contest Closes February 24th

The original type of contest is now being run. That is to say, there is no restriction on the geographical location of the stations to be entered in any one contest. Each contest is world-wide. Stations heard and verified during any thirty-day period, regardless of their

location, are acceptable provided that at least 50% of the stations submitted are from countries other than the one in which the contestant resides. The June contest will close on March 24.

## Contest Rules

The purpose of this contest is to advance the art of radio by "logging" as many short-wave phone stations as possible.

A notarized affidavit must be sent with the veri cards.

By midnight, Feb. 24th, all entries for the May contest must be in the hands of the Editors, together with the veris and the notarized oath that the contestant personally listened to all of the stations listed.

In the event of a tie between two or more contestants, each listing the same number of stations, the judges will award a similar trophy to each contestant so tying.

Bear in mind that the veri cards should be absolute verifications, and not simply an acknowleg-

ment that you notified a station that you heard them. Several stations do not verify, but simply send an acknowledgment card. Note that only experimental, phone, or broadcast stations should be entered in your list. No amateur transmitters or commercial code stations can be entered.

The judges in each contest will be the Editors of SHORT WAVE & TELEVISION and the opinion of the judges will be final.

Send veri cards with your letter and oath certificate all in one package. Use a single line for each station and list them in a regular order, such as: frequency, schedule (all time should be reduced to E.S.T., which is five hours behind G.M.T.), name of station, city, country; musical identification signal if any.

Please mention SHORT WAVE & TELEVISION when writing advertisers

# Scouts

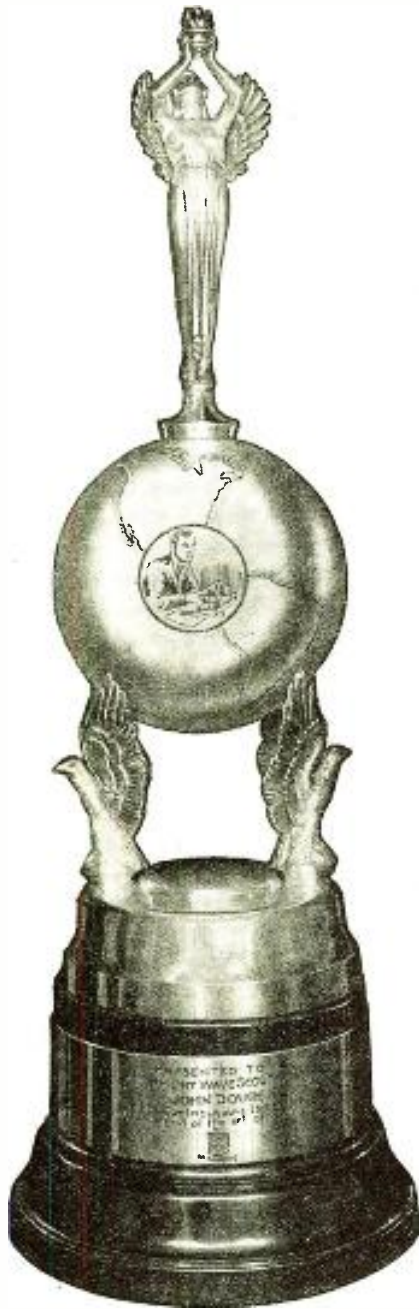

The handsome trophy which was designed by one of New York's leading silversmiths. It is made of metal throughout, except for the base, which is black Bakelite. The metal itself is quadruple silver-plated, in the usual manner of all trophies today.

It is a most imposing piece of work, and stands from tip to base 22 1/2". The diameter of the base is 7 3/4". The diameter of the globe is 5 1/4". The work throughout is first-class. It will enhance any home, and will be admired by everyone who sees it.

The trophy will be awarded every month to that SHORT WAVE SCOUT who has logged the greatest number of short-wave stations in each contest as explained in the rules. The winner will be announced in a subsequent issue of SHORT WAVE & TELEVISION. The winner's name will be hand engraved on the trophy.

## THE 1938 SUPER-CLIPPER!



**7 Tubes Bands!**  
THREE STAGES OF RADIO FREQUENCY AMPLIFICATION Including

*Built-In Signal Booster and Preselector!*

**THE SUPER-CLIPPER HAS BEEN DESIGNED FOR DX HUNTERS—IT HAS ALL THE FEATURES YOU HAVE EVER ASKED FOR BUILT INTO A SINGLE, BIG RECEIVER WITH EVERY USEFUL CONTROL AT YOUR FINGER-TIPS.**

### UNUSUAL DX RECEPTION

The SUPER-CLIPPER guarantees you consistent foreign reception, and goes further; you can expect the *unusual* in longdistance reception with this *big record-breaking receiver*. Big?—Yes, big in size and bigger in performance—19 inches wide, 10 inches high and 9 inches deep! No crowding of parts on its large, well-designed chassis. *Efficiency* dictated the mechanical and electrical layout of this *superb set*.

The SUPER-CLIPPER circuit utilizes both regeneration and super-regeneration combined with radio frequency amplification. The tube line-up is: 6K7 R.F. Booster; 6K7 R.F.; 6K7 Ultra-high R.F. (separate channel); 6J5G Detector; 6J5G 1st audio; 6L6G Power output; 80 Rectifier.

### A Few of Many Features

- Built-in Signal Booster and Preselector which permits foreign stations to be separated and weak ones built up to loudspeaker volume. Covers same range as main tuner, and is tuned automatically with it but may be switched out of circuit for stand-by tuning and local high fidelity reception.
- Calibrated reduction drive tuning dial covering from 22 to .54 megacycles (13 to 555 meters) in four overlapping bands controlled by bandswitch (NOT plug-in coils).
- Both electrical and mechanical bandspread entirely eliminating critical tuning on weakest foreign stations. A separate bandspread and ultra-high frequency condenser is used.
- Two stages of powerful audio amplification with 6L6 beam power output.
- Separate ultra-high Frequency R.F. channel (3 to 12 meters) using air-wound coils and 6K7 R.F. amplifier. (Separate antenna connection is provided for maximum efficiency.)
- Six one-half inch dynamic speaker; Noise and Tone Control; Earphone jack, etc.: The SUPER-CLIPPER has every worthwhile feature that you would like to have in your personal receiver.

*The New 1938 Super-Clipper* complete with 7 tubes, ready to plug in to A.C. 110 v. line and operate. Guaranteed for one year

Shipping weight 30 lbs. **\$29.75**  
NOT SOLD IN KIT FORM

## UNIVERSAL CLIPPER 5-TUBES

ONE OF THE FINEST LONG DISTANCE RECEIVERS WE HAVE EVER BUILT

Uses the same sensitive circuit as the SUPER-CLIPPER without the preselector. This allows a saving of two tubes, as the same RF amplifier can be used on all frequencies. Has the same tremendous tuning range of from 3 to 555 meters. Every short wave foreign broadcast and amateur band is covered, together with the new ultra-high frequency television and high fidelity stations between five and ten meters.

Both electrical and mechanical bandspread over the entire tuning range and a filter circuit which is really quiet allows the finest tuning of weak, long distance signals. (The filter circuit is also identical with the SUPER-CLIPPER, NOT the usual inadequate AC-DC affair).

ASK THE MAN WHO OWNS A CLIPPER—LOOK AT HIS LOG!  
COMPLETE KIT WITH ALL PARTS ASSEMBLED and wiring diagram; less only tubes and cabinet, unwired ..... **\$12.40**  
Black crackle finish cabinet ..... 1.80  
Matched set of five tubes ..... 3.20  
Wiring ..... 2.90  
UNIVERSAL CLIPPER—COMPLETE, with black crackle cabinet, (20" x 10" x 9"); five tubes; 6K7, 2-6J5G, 25L6, 25Z6G; ready to operate, and one-year guarantee ..... \$19.50  
Special Complete Price

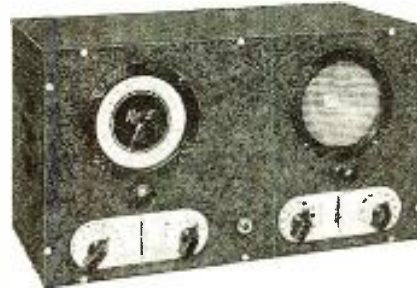

### FEATURES!

- Bandswitching (7 bands) with five tubes in use at all times.
- Bandspread over entire frequency range.
- RF amplifier operates on all bands (100 megacycles to 545 KC).
- Beam power output and dynamic speaker.
- Haynes electron coupled detector circuit giving either regeneration or super-regeneration from the same tube.
- Universal operation from any 110 volt line—either AC or DC.

**RACO** RADIO CONSTRUCTORS LABORATORIES  
136 LIBERTY ST. Dept. S-3 NEW YORK, N. Y.

Please mention SHORT WAVE & TELEVISION when writing advertisers

# A NEW INSTRUMENT by SUPERIOR

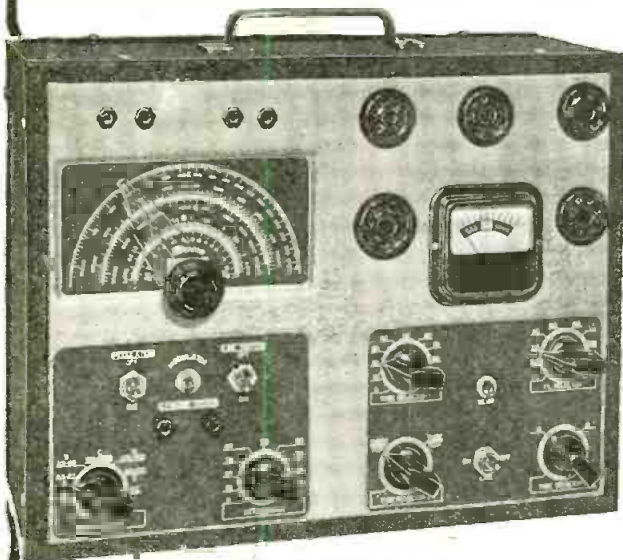

**Combination Instrument—**  
**ALL-WAVE SIGNAL GENERATOR PLUS A COMPLETE TUBE TESTER ONLY \$19.90**

● Truly the greatest value ever offered by any instrument manufacturer! There is no comparison to the COMBINATION INSTRUMENT, made by Superior, at the price of \$19.90. Consists of two fully complete units housed in a single metal cabinet of attractive design: (1) an ALL-WAVE SIGNAL GENERATOR and (2) COMPLETE TUBE TESTER. ● The Signal Generator has a range of from 110 kc to 22 mc, all fundamental frequencies, in five bands—with front panel band-switching control. ● All frequencies are directly calibrated on the dial, and a 4 to 3 planetary drive is incorporated to allow for slow precise tuning adjustment. ● R.F. signal with or without audio modulation, at the control of the operator. ● Separate RF and AF outputs, with two AF amplitude levels. ● Accuracy 1 percent on IF bands, 2 percent on short-waves. ● Separate Neon leakage test circuit, for testing condensers, etc. ● Employs three tubes; 2-6A7's and one special neon modulator tube. ● The TUBE TESTER tests all 4, 5, 6, 7 and octal base tubes, including diode tubes. ● Incorporates separate neon short or leakage test, to determine whether tubes are bad, noisy or leaky. ● English reading meter, with "BAD—GOOD" scale. ● Uses minimum number of operating controls, allowing tube tests to be made quickly and accurately. ● Sturdy, reliable and foolproof emission type circuit.

Shipping weight—19 lbs.

Write today for Superior's New Catalog—"At Your Service." It describes the complete line of Superior Test Equipment.



**FREE Catalog!**

**SUPERIOR INSTRUMENTS COMPANY 136 LIBERTY STREET Dept. SWT-3, New York, N. Y.**

New—  
 Different—  
 Inexpensive—  
 Highly Efficient!



**CONDENSERS perform better.**

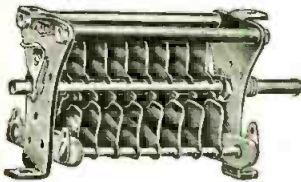

**NEW BUD JUNIOR TRANSMITTING CONDENSER**

Here's a new construction with efficiency greater than ever!

Lightweight, rigid, perfectly aligned, fully insulated, it is adaptable to several types of mounting: panel, chassis, or with rotor opening downward.

The new design gives a larger capacity ratio—most desirable in multi-band transmitters.

**BUD JUNIOR DUAL TRANSMITTING CONDENSERS**

With the same improved construction as the single units, this condenser gives the greatest maximum to minimum capacity per section.

These condensers are better because:

- Better circuit capacity balance to ground is obtained
- Parasitics are less apt to occur
- Neutralization is easier
- Hand capacity effects are reduced greatly

Once again BUD leads the field in offering "THE BEST FOR LESS"

**BUD RADIO, INC. CLEVELAND, OHIO., U. S. A.**

## The One Practical ELECTRIC WORLD TIME CLOCK

Brushed Brass Case

The Sky Pilot is Educational and Essential for Radio. Can be set for all world time zones. 3 clocks in 1. For 110-120 Volts, 60 Cycle, A.C. Only. Also in 12 inch model. **\$5.95** Literature on POSTPAID if Not at Request. Your Dealers. **The SKY PILOT ORGANIZATION Ossining, N. Y.**

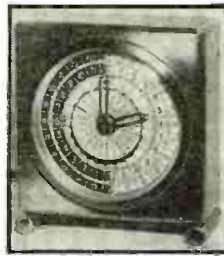

## CRYSTAL HEAD PHONES

## "TRANSFILTER"

Information on request

**THE BRUSH DEVELOPMENT CO. 3326 PERKINS AVE., CLEVELAND, OHIO.**

**You need our 1938 Catalog**

It illustrates and describes our complete line of

**RACKS • PANELS • CABINETS**

Write for your Free Copy Today!

**PAR-METAL PRODUCTS CORP. 3529 41st St., Long Island City, N. Y.**

## Television Terms Explained

—A—

**ANODE**—In any electronic tube this is a metallic collector to which electrons flow. This electrode is always made positive with respect to the cathode. Synonymous to the term "Plate."

**APERTURE DISTORTION**—A loss of image definition because of physical width of the scanning aperture, the height of the aperture being equivalent to the height of one scanning line.

**ASPECT RATIO**—The ratio of the picture width to picture height of the picture frame area.

**AUDIO FREQUENCY**—The range of frequencies to which the ear normally responds and produces the sensation of sound. This is generally said to include the range from 15 to 16,000 C.P.S.

**AUTOMATIC BACKGROUND CONTROL**—A term descriptive of a method of automatically controlling the background illumination of a cathode ray tube reproduced picture by modulating the cathode ray intensity with the DC component of the video signal.

—B—

**BLACK CONTROL**—A synonym for "Automatic Background Control."

—C—

**CATHODE**—The electrode from which the electrons are expelled. In most tubes all electrons start from the cathode, and most of them reach the anode.

**CATHODE RAY**—The cathode ray is an emission of electrons from a cathode that travel nearly parallel to each other for a distance that is many times their maximum separation from each other.

**COAXIAL CABLE**—A special type of transmission cable capable of passing a wide range of frequencies without the usual prohibitive losses and distortion. The cable consists of an inner conductor running concentric with, equally spaced and insulated from, the inside of the outer conductor. In this type of line, external radiation is almost entirely suppressed.

**CONCENTRATION COILS**—One or more solenoids of wire placed around the neck of a cathode ray tube to assist in focusing the cathode ray. The concentration coils are the magnetic version of the Electron Lens which depends upon electrostatic action.

**COMPOSITE TELEVISION SIGNAL**—(As defined by the Radio Manufacturers Association) By a composite television signal is meant a signal in which the combined video, blanking, and synchronizing signals are present.

**CONSECUTIVE SCANNING**—A method of scanning a television image where the field frequency and frame frequency are the same.

**CONTRAST**—Refers to the sharpness of the border lines that mark edges between the dark and light portions of the screen. The solution to this requirement is the most difficult problem in television.

—D—

**D-C VIDEO COMPONENT**—That part of the video signal due to the average steady background illumination of the scene being transmitted.

**DEFLECTION COILS**—A pair of magnetic coils placed alongside the neck of a cathode ray tube, with their axes perpendicular to the ray to deflect the path of the latter in a new direction. The amount of deflection is proportional to the current through the coils; the deflection is at right angles to the magnetic field.

**DEFLECTION PLATES**—Generally a pair of metallic plates placed in the neck of the cathode ray tube between anode and screen. Their purpose is to deflect the cathode beam through electro-static action by means of potentials placed on these plates.

**DELAY SCREEN**—A certain type of fluorescent screen used in cathode ray tubes which also possesses the property of phosphorescence. Thus, light will remain on a portion of the screen for some time even after the light spot has traveled on to another position.

**DETAIL**—Descriptive of the clarity and sharpness with which small objects in the image can be distinguished.

**DIODE**—In the elementary sense, an electron tube containing an electron-emitting cathode and an anode. The tube is essentially a half-wave rectifier.

**DIPOLE ANTENNA**—A Hertzian half-wave antenna ideally suited for ultrahigh frequencies.

**DIRECT PICK-UP**—The use of a "Television Camera" to televise a subject directly from life. A contrast to this is the televising of scenes from film. See "Telecine Transmission."

**DOUBLE SIDE-BAND TRANSMISSION**—The system of modulation used today to transmit intelligence, whereby both upper and lower sidebands are transmitted in addition to the carrier frequency.

**DISSECTOR TUBE**—Also called "Image Dissector Tube." This is a signal pick-up tube developed by Farnsworth for use in his television camera. It is the equivalent in video transmission to the microphone in audio transmission.

**DIVERGENCE**—The spreading out of a cathode ray beam in its travel away from the cathode due to the mutual repulsion existing between the individual electrons comprising the beam, since all electrons represent a negative charge. It is because of the tendency to diverge that it is necessary in some manner to focus the electron stream to a small spot.

#### —E—

**ELECTRON LENS**—A symmetrical arrangement of electro-magnetic or electro-static fields about the axis of the cathode ray, the prime purpose of which is to prevent divergence of the cathode ray in its travel away from the cathode, thereby controlling the focusing of the beam to any desired spot size on the cathode ray tube screen. See "Concentration Coils."

**ELECTRON MULTIPLIER**—A special tube (a by-product of television experimentation) which is capable of extremely high gain. It may employ either a photoelectric or thermionic cathode, and depends upon secondary emission for its action.

**ELECTRON RAY**—Same as a cathode ray.

**ELECTRODE**—One of the metal elements built into a vacuum tube which plays a part in the electronic action of the tube. It is connected to an external circuit. Examples of tube electrodes are: cathode, screen grid, plate, suppressor grid, grid, etc.

**EMISSION**—The continuous ejection of electrically charged particles, either ions or electrons (usually electrons), into surrounding space (evacuated space in the case of a vacuum tube) from an emitting surface. Three types of emission are important in radio and television applications: Thermionic, Photoelectric, and Secondary.

**EMISSION-PHOTOELECTRIC**—An emission of electrons from a specially prepared surface sensitive to light. There are about seven such elements which have sufficient photoelectric properties to be com-

mercially usable. These are: Lithium, Sodium, Potassium, Rubidium, Caesium, Strontium, and Barium.

**EMISSION-SECONDARY**—An emission of electrons from a material, caused by the bombardment of the surface of the material by high speed electrons which possess sufficient kinetic energy in themselves to dislodge electrons from the metal being bombarded.

**EMISSION-THERMIONIC**—The continuous liberation of electrons from a surface, usually a cathode, because of high temperature of the emitting element.

**EVEN LINE INTERLACE**—An interlaced scanning process in which the number of lines scanned during each frame is an even integer.

#### —F—

**FACSIMILE**—The transmission and reception of a picture, drawing print or photograph by breaking down the image to be transmitted into minute picture elements, transmitting each as a separate impulse. These elements, when assembled at the receiver, will form essentially a half-tone, permanent record of the image transmitted. Normal facsimile uses 120 lines per inch; therefore, definition can be increased by increasing the dimensions of the picture to be transmitted, in effect giving more lines per picture, while in television, increasing the picture area does not increase detail—the number of lines in the picture stays the same.

**FIELD FREQUENCY**—(As defined by the Radio Manufacturer's Association) The field frequency is the number of times per second the field area is fractionally scanned in a system using interlaced scanning.

**FIELD FREQUENCY BLANKING IMPULSE**—An electrical impulse of special wave shape transmitted at the end of each vertical "scan" of the picture field for the purpose of erasing the return path of the cathode ray spot on the screen of the television picture tube.

**FIELD FREQUENCY SYNCHRONIZING IMPULSE**—Also known as "Vertical Synchronizing Impulse." An electrical impulse of special wave shape transmitted at the end of each vertical "scan" of the picture field. The purpose of this electrical pulse is to keep the vertical "scan" of the television receiver tube in synchronization with that at the transmitter.

**FILAMENT**—The heating element by means of which the necessary high temperature of the cathode is maintained so that electrons can be emitted by the cathode. In cases where there are no indirectly heated cathodes, the filament itself is the electron emitter.

**FILTER, AMPLITUDE**—A filter circuit whereby certain pulses can be selected from other electrical pulses because of a difference of their amplitudes. Used for synchronizing circuits to select proper synchronizing pulses for line and field frequencies.

**FLUORESCENCE**—The ability of a substance to give off light of a characteristic color (wave length), dependent upon the material used when exposed to light or bombardment by X-rays, high speed cathode ray beams, etc. The latter is the cause of the creations of the light spot on the screen of the cathode ray tube.

**FLUX-LIGHT**—Referring to light rays.

**FORMAT**—This is a synonym for "Aspect Ratio."

**FRAME**—The completed scan of one complete picture.

**FRAME FREQUENCY**—The number of times per second that complete pictures are produced on the screen to provide the illusion of movement.

(Continued on page 652)

WHEREVER TUBES  
PLAY A VITAL PART

YOU'LL FIND  
**RAYTHEON**  
ON THE JOB!



It is just as important for you to use top quality tubes as it is for the United States Navy. They use Raytheon because it is the tube that can be depended upon to work smoothly in any circuit... and stand up under the roughest usage and thundering vibration of a battleship under fire. The Navy can't stop in the middle of a battle to find which tube has blown!

Leading licensed set manufacturers, too, prefer Raytheon because of their sturdiness and uniformity. And when you make a replacement in a receiver or need an Amateur Tube, you must be just as confident. That is why thousands of amateurs all over the world depend upon Raytheon.



"WORLD'S LARGEST  
EXCLUSIVE RADIO  
TUBE MANUFACTURERS"

**RAYTHEON**

CHICAGO • NEW YORK • SAN FRANCISCO  
ATLANTA • NEWTON, MASS.

Please mention SHORT WAVE & TELEVISION when writing advertisers

## ULTRA MODEL 1A1 Precision Signal Generator



- Wide range 100 K.C. to 66 M.C. (3000 to 4.5 meters).
- Direct reading dial accurately calibrated for entire range.
- Accuracy of calibration 1/2 of 1% on I.F. and broadcast bands, 1% on short wave bands.
- High ratio vernier dial drive with hair splitting pointer.
- Separate outputs for both R.F. and audio.
- Attenuator for both R.F. and audio channels.
- Modulated or unmodulated R.F.
- Pure sine wave audio output.
- Due to pure wave form of both R.F. and audio outputs the unit may be used in conjunction with an oscillograph.
- Tests condensers for opens and shorts by pitch method.
- Outstanding appearance. Unit has beautifully etched metal panel.
- A.C. and D.C. operation. Any cycle.
- Supplied for 110 volt A.C. and D.C. operation. May be supplied for any operating voltage from 110 volts up, on request at no extra charge.

Model 1A1 Precision signal generator supplied complete with tubes, cabinet, and operating instructions as illustrated and described.

**\$12<sup>50</sup>**

IF YOUR DEALER CANNOT SUPPLY YOU, ORDER DIRECT.

**ULTRA PRECISION INSTRUMENTS CO., Inc.**  
123 Liberty St., Dept. S-3 New York City



## TRANSOIL

for transmitting

**HIGHEST QUALITY  
OIL CAPACITORS**

Ask for new complete  
Transmitting Catalog  
describing

TRANSOIL SOLAR-TRAMSOIL

SOLAR  
MFG. CORP.

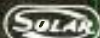

599 BROADWAY,  
NEW YORK CITY

## YOU CAN RECOMMEND CANNON-BALL PHONES



**Cannon-Ball Adapter**

permits using headsets on  
all radios. Get diagram  
and complete details.

**C. F. CANNON COMPANY**  
SPRINGWATER, N. Y.

### To Friends

who want the best  
in radio. Clear,  
private reception.  
Satisfying folks  
over 20 years.  
Write Headset  
Headquarters for  
folder S-2 illustrating  
complete  
line.

## BLILEY CRYSTALS

10-20-40-80-160 Meter Bands

Now \$3.35 up.

Bliley Electric Co., Erie, Pa.

## The Future of U.H.F. in Air Transport

H. M. HUCKE

(Continued from page 597)

lanes of planes taking off simultaneously. Instant short range voice communication from two ultra high frequency control tower transmitters will be required to safely handle 60 planes per hour on such an airport.

The list of ultra high frequency devices for aircraft is limited only by our engineers' imagination and time to perfect them. With domestic air transport companies employing a total of thirty-five engineers in their communications research departments there are few possibilities which have not been considered. Ultra high frequency direction finding, collision warning, radio altimeters, radio meteorographs and televising through fog—all have been discussed. Each has its series of obstacles which must be overcome before the requirements of commercial reliability can be attained. Several are conflicting and the successful development of one may nullify the value of another.

Much ground-work must be completed before some of these devices can come into daily service. Since the safety of human life must be considered, the popular *transceiver* type of radio equipment cannot be used in transport aircraft. Present aircraft-receiver reliabilities have been increased until, if installed as auto radios, they would operate throughout the useful life of six automobiles before a single failure occurred. To be doubly sure, a duplicate receiver with independent power supply is carried in case the single failure should occur during bad weather. All ultra high frequency equipment must give equivalent reliability and must be duplicated if its failure has any bearing on the safety of flight.

Electrical circuit reliability is equally as important as mechanical reliability. A receiver whose tuning has drifted at sub zero temperatures is just as unsafe as a receiver which has failed due to a short-circuited condenser. Tuning drift with temperature changes is considerably more severe in ultra high frequency equipment than in our

present low and medium wave equipment. Frequency stability in receivers and transmitters is one of the first great problems which must be overcome. The F.C.C. on October 13, 1937 allocated the 130 mc. airport control frequencies 500 kc. apart because the existing receiver selectivities and transmitter stabilities would not permit closer channel spacing. If our broadcast receivers and transmitters were this poor, we could only allow three stations in the entire broadcast band.

The transmitter stability problem is not as serious as the receiver problem. A satisfactory 400 watt transmitter having a stability of plus or minus 5 kc. at 91 mc. has been in experimental use for more than a year. Commercially available "A" cut quartz crystals are used in the controlling stage.

Receivers are not so well developed. Present plans call for superheterodyne receivers with "A" cut crystal controlled oscillators and intermediate frequencies of about 5 mc. These receivers are only useful for fixed frequency services. Receivers which will tune over the airport band of 129 to 132 mc. and retain their dial calibration while the plane rises from a ground temperature of 100° F. to an upper air temperature of—10° F. are non-existent. Temperature controlled oscillator and tuned radio frequency stages will probably be necessary to provide stability. Concentric transmission lines may be used instead of helical coils to provide selectivity. For amplification at 130 mc. we must look to the tube manufacturers. The present "Acorn" tubes, while satisfactory experimentally, fall considerably short of aircraft standards. The crying need of ultra high frequency receiver designers is a commercially reliable tube which will give good stage gain when used with transmission-line interstage coupling.

All these things will come within the next ten years. The recent opening of the 30 to 300 megacycle band by the F.C.C. will hasten a multitude of parallel developments which will improve the basic requirements of better stability, selectivity and stage gain. As these improvements are made, more and more ultra high frequency radio devices will be used on aircraft. Each additional unit will increase reliability until planes will easily leave Chicago in a blinding snow-storm, fly above the clouds in sunshine and comfort, and land at San Francisco in a dense fog without having seen the earth since departure.

## You Can "See" Over This Telephone Line Between German Cities

(Continued from page 599)

actual reproduction of the images of two persons carrying on a conversation over the system. The images shown are those observed on the monitor in the telephone exchange. In this way, the telephone operator has control over the service afforded the public, and if she sees that one of the faces, for example, is not very clear, she advises the person at that particular end of the line to move further away or closer to the apparatus, as the case may be. This instruction would invariably come at the start of the conversation and once the person had been told to move back or forward, so as to be in proper focus, he would subconsciously hold that position during the conversation period.

In the earlier models of the apparatus used to pick up the image from the television-phone booths, invisible infra-red light was used to illuminate the person's face.

Please mention SHORT WAVE & TELEVISION when writing advertisers

# Alignment Procedure for the All-Wave Superhet

(Continued from page 615)

used. It is usually a separate tube also when a triode, tetrode or pentode is used as a first detector. If the oscillator is included in the triode, tetrode or pentode first detector circuit, it may be stopped by *shorting* the grid or feedback coil. This is the only practical way to avoid oscillation as it does not disturb the operating voltage regulation of the set.

When this is done properly, the bias on the first detector signal input grid will not be disturbed. Of course, in cases where a cathode resistor is used, there will be no alteration of the bias, but if none is used it will be necessary to connect the signal-generator ground-lead to the A. V. C. line to which the -3 volt terminal has been connected. When the control grid cap is removed the grid circuit is opened. It is therefore essential that a resistor be placed from this grid to ground, or to the -3 volt terminal, depending on the circuit.

The entire problem is to replace the regular signal with one from a signal generator, without changing the input electrical characteristics of the first detector. To avoid troublesome connections it is sometimes possible to get good results by coupling the HIGH lead from the signal generator to the second detector plate through a very small capacity (.0001 mf. or smaller).

For a small set, there may not be enough gain to do this and in any event the coupled circuit often changes the electrical characteristics of the first I.F. transformer.

Another connection may be used where the I.F. amplifier is a high-gain multi-stage high frequency one. This is simply to wind several turns of wire with insulation over the control grid lead *without removing it from the tube*. This wire is connected to the HIGH post of the signal generator and usually will drive a signal through to the output. With this connection, the antenna should be disconnected or shorted to ground, or the R.F. tube, if one is used, must be removed. The tuning condensers should be turned for the *least* possibility of receiving a station.

## The Alignment

The set and signal-generator must be allowed to operate for 8 or 10 minutes, so that they may reach normal operating temperature.

Once the connections are made the actual alignment procedure is quite simple. Select

an *insulated* screw-driver or socket wrench which will turn the I.F. trimmers and starting with the second detector input tuned circuit, progress backward toward the first detector plate circuit, adjusting each trimmer for the indication specified in the table.

Where separate amplified A.V.C. is employed, after the signal circuit is adjusted, the A.V.C. should again be brought into action and adjustment should be made for the *opposite* indication to that just described.

We begin at the second detector because the circuits are most critical at this point. Thus by progressing from the most critical stages to the least critical ones, we make the most exact alignment without readjustment.

## The A.F.C.

An individual adjustment is required for A.F.C. (Automatic Frequency Control). The same output connections will not indicate the adjustment of the A.F.C. Therefore, connect a high resistance type of voltage indicator (not a neon type) between the ungrounded cathode of the discriminator tube and ground, adjusting for minimum response. Switch the A.F.C. switch on and off and continue to readjust the discriminator trimmer until the reading remains zero for either position of the switch.

## The R.F. Alignment

The output indicator is applied the same as for I.F. testing according to the table. The signal generator is attached at the antenna and is operated at the lowest signal consistent with a detectable output.

There is no specified order of adjustment of wave bands, so we will use the usual procedure of starting with the broadcast band or lowest frequency band and proceed to the highest.

Turn the wave-band switch to the broadcast position, and tune both the receiver and signal generator to 1400 kc. or to a point near this value where there is no appreciable field intensity from any broadcast station.

Start with the oscillator trimmer in shunt with the oscillator main tuning condenser, adjusting for the indication to be expected as of the table. Next adjust the R.F. trimmers in shunt with the other main tuning condensers for similar indications. In accordance with the table, a modulated or unmodulated signal may be used. While at this frequency, the trimmers are across

A.C. Voltmeter, Neon Indicator, or Oscilloscope

Connection	Range Approximately	Signal	Indication for Best Adjust.
1. Across voice coil.	0-10-25 volts	Modulated	Maximum
2. Plate to plate (output tube)	0-150-500 v.	Modulated	Maximum
3. Plate to ground through .1 mf. condenser	0-150-500 v.	Modulated	Maximum
4. Driver plate through .1 mf. to ground	0-50-150 v.	Modulated	Maximum
5. Output tube (grid to grid)	0-150 v.	Modulated	Maximum
1. Series with voice coil	A.C. Ammeter 0-1/2-1 a.	Modulated	Maximum
D.C. Voltmeter and Neon Indicator			
1. Across plate detector cathode resistor	0-50 v.	Mod. or Unmod.	Minimum
2. Across A.V.C. controlled tube cathode resistor	0-5-10 v.	Either	Minimum
D.C. Milliammeter, Shadowgraph or Reactance Dimmer			
1. Series with second detector plate circuit for grid leak det.	0-10 ma.	Either	Minimum
2. Series with diode plate 2nd det. return or cathode	0-1 ma.	Either	Minimum
3. Second det. (plate type) series with plate circuit	0-1 ma.	Either	Maximum Minimum
4. Series with I.F. amplifier plate circuit (A.V.C. controlled)	0-10-25 ma.	Either	Maximum Minimum
5. Series with common B+ lead to A.V.C. controlled tubes	0-25-50 ma.	Either	Minimum
6. Common plate supply (series) class B output stage	0-150-300 ma.	Modulated	Maximum
The Electric Eye			
1. A.V.C. supply lead at grid return	G type	Either	Min. Shadow
2. Across diode load. vol. control using A.V.C.	G type	Either	Min. Shadow

# ALLIED offers RADIO'S GREATEST VALUES

**NEWEST SETS**

**OVER 12,000 PARTS**

**DOZENS OF KITS!**

**SOUND EQUIPMENT!**

**TEST EQUIPMENT!**

FOR DEALERS • SERVICEMEN  
SOUND MEN AMATEURS SET BUILDERS

## Everything in Radio AT LOWEST PRICES!

What's your interest in Radio? Do you sell sets? Build? Service? Whatever you need, ALLIED has it and can save you money. Our big 164-page book shows over 12,000 radio parts; Sound Systems for every need, 8-60 watts, portable, mobile, permanent; Intercom Systems; all types of testers, analyzers, tube-checkers, set-testers, meters, signal generators; Amateur receivers, transmitters, transceivers; Build-Your-Own Kits; books, tools, etc.—and 61 great "Knight" Radios offering newest features, Push-Button Tuning, etc., at amazingly low prices. Radio men everywhere say, "ALLIED'S catalog's the place to shop; it saves you time and money!" Get this big Book of Values now—it's Free—just send coupon.

### FREE! BUILDER'S PART LISTS

We supply Free Parts Lists of matched kits for building any circuit described in this or in any other magazine. Just specify where seen.



## Free CATALOG

ALLIED RADIO CORP.,  
833 Jackson Blvd.,  
Chicago, Ill. Dept. 3-C-3.

Send your 1938 Catalog Free.

Name .....

Address .....

City ..... State .....

Please mention SHORT WAVE & TELEVISION when writing advertisers

**BRUNSWICK 6 TUBE**  
 2-6 Volt Battery Console Receiver  
 Uses—5-30 and 1-31 tube or 4-201-A and 1-71-A tubes, 4 gang, 4 tuned currents, single control.  
 Brand new. Factory sealed cases. size of console, 40x21x14 1/2"—shipping weight, 70—no C.O.D.—Express or Freight only. **\$3.95**  
 AD-6668

**KOLSTER 7 1/2 WATT**  
**PUBLIC ADDRESS AMPLIFIER**  
**TRANSMITTER POWER SUPPLY**

This 210 or 250 tube amplifier unit with 12 1/2" 25 Watt speaker, brand new in factory sealed cases, costing over \$100.00, ready to use as amplifier and tapped power supply. Conversion diagram for making 15 Watt High Gain amplifier furnished free. Shipping weight 80 lbs. Makes a fine P. A. system. **\$4.95**



**ZENITH 2-6 VOLTS**

"A-B" SUPPLY FOR:  
 AUTO—HOME and FARM—Air Cell—2-6 volt Battery Sets.  
 MADE TO SELL, FOR \$15.00—the finest power supply made will operate from a 6-volt battery, delivery 250 volts—100 mls.  
 Ideal for portable car—X meters will also operate on 4 volts with an output of 175 volts—50 mls. Pack is housed in copper-plated case—3"x4 1/2"x6 3/4"—comes packed complete with battery clips, plugs, cables—and full operating instructions.  
 Limited Quantities—Shipping weight, 6 pounds—AD-17421 **\$3.95**

**5 BAND ALL WAVE TUNING UNIT**

42,000 K.C. to 550 K.C.  
 (7 to 600 meters.) Completely assembled and wired. Complete switch, an all wave Super-Het. YALEX single knob band switches. Genuine MEISSNER coils. Unit completely wired with all connections soldered; CD mica condensers, etc. Can be installed in your present receiver by connecting grid and plates of 3 tubes. Size of unit 8"x8"x2 1/2". AD 6666—tuning unit assembled and wired reg. price \$12.95..... our Price \$4.95  
 Complete instructions and diagrams.....25c  
 This unit can be made into an 8 or 10 tube set. Kit of all essential parts for 8 tube set—\$9.95.  
 Kit of tubes \$6.25. Kit of parts—10 tube set \$11.96.  
 Kit of tubes \$6.35. Less speaker, chassis and dial.  
 Magic eye tuning unit \$1.00 extra. Magic Eye tube, 90c extra.

Send Stamps for our Money Savings Catalogue—check full of over 1,000 Red Hot items at Lowest Prices in the U. S.

**UNITED RADIO COMPANY**  
**58-B Market Street**  
**Newark, New Jersey**

Ask your **JOBBER**  
 for the NEW  
**STANCOR**  
**"HAMANUAL"**  
 New Tubes... New Circuits  
**16 NEW TRANSMITTERS**  
 5 WATTS TO 1000 WATTS  
**STANDARD TRANSFORMER CORPORATION**  
 850 BLACKHAWK STREET, CHICAGO

**RADIO IN ITS ENTIRETY!**  
 "B.A." serves the trade with every need in radio—complete 160-page catalog of nationally known radio receivers, public address, parts, supplies and equipment. Orders shipped same day received.  
**COMPLETE CATALOG AVAILABLE**  
**BURSTEIN-APPLEBEE CO.** 1017-14 McGEE ST. HANSAAS CITY, MO.

the coils in such a way that when the wave-band is changed, they remain across the coils. Care must be taken to be sure that the right trimmers are adjusted. This may be determined from a layout drawing of the set or by tracing connections. Next tune the signal generator and set to 600 kc and adjust the oscillator padding condenser for proper indication as shown on the chart. This is the one in series with the oscillator coil.

For the balance of the bands the exact frequencies for alignment cannot be specified and are not important. Simply shift the wave-band switch to the next band, tune the receiver near to, but *not* at the highest frequency covered by this band and adjust the oscillator and other trimmers, progressing from the oscillator toward the antenna. To avoid false adjustments due to distributed "end-capacity" effects, the frequency chosen should be at least 10% lower than the maximum one to which the stages will tune on that band. Adjust the signal-generator for resonance with the receiver before making the adjustments, of course.

In some cases it may be possible and desirable to make the adjustment so that the frequency received will correspond exactly to that indicated on the dial (if it is calibrated). Remember that this is not always possible at every point on the dial. If all the readings are low or high the dial scale may usually be shifted or rotated to the proper place.

Adjust the shunt trimmers at the highest frequency for that band and the series pad-ders at the lowest frequency in the band. The lowest frequency may be the maximum setting of the tuning condenser, although 10% above this value will be suitable and in some rare cases, advisable. Here again we avoid any possibility of "end-capacity" effect by this procedure.

Repeat the above steps for each band. The trimmer may not be across the entire coil in which case its adjustment will be less critical than usual. You will have no trouble distinguishing adjustable condensers from coupling, by-passing, etc., as the formers' construction allows for adjustment while the latter have no provision for adjustment.

**The Antenna Trap**

A good many receivers are provided with antenna wave-traps to minimize or eliminate image reception, due to beats with the desired signal formed by interfering signals in the first stage. Many of these traps are adjusted to 450 kc, which covers the 400 to 500 kc. region fairly well when only one circuit is used.

A 450 kc. signal could combine with a 625 kc. signal for example, forming a beat of 175 kc., which would cause interference in the I.F. amp. If the I.F. of the set is fairly high, above 350 kc., for example, the input circuit would normally take care of this type of interference.

If a wave-trap is used in this case, it is to prevent entrance of interfering signals having fundamental or harmonic frequencies equal to the I.F. This serves to minimize image interference at any setting of the receiver tuner. The signal generator (high connection) is then connected to the antenna and ground and adjusted to the frequency to which it is desired to tune the trap. This may be determined only from the set manufacturers' specifications.

The trap circuit is then adjusted for minimum response where a maximum response is called for in the table, and a maximum response where a minimum one is called for in the table. This is done because the trap is a signal "rejection" circuit. At resonance a minimum signal should be indicated.

**PYRO PANTAGRAPH**



Size of Box: 12 1/2 x 8 1/2 inches **\$2.75**  
 Shipping weight, 3 lbs.

THIS electrical outfit is especially designed for burning designs permanently on materials such as Leather, Wood, Cork, Bakelite, etc. Plug the Pyro-electric pencil in any 110 volt AC or DC outlet and it is ready to be used. Plug and cord furnished.

By the use of the Pantagraph included in the outfit, any design may be reproduced either in original, reduced or enlarged form. Outfit consists of: one Pyro-electric Pencil; one Pantagraph; three hardwood plaques; one bottle of Varnish; one Brush; one tracing tip and four-page instruction sheet. Size of box: 12 1/2 x 8 1/2 inches.

Outfit will be forwarded by Express Collect if not sufficient postage included with your order.

**WELLWORTH TRADING CO.**

558 W. Washington Blvd. Dept. SWT-338 Chicago, Ill.

**STOPPANI COMPASS**



A Precision Instrument made in Belgium. Purchased by the U. S. Government at more than \$50.00 each. Ideal for Radio Experimenters Laboratory, also may be used as a Galvanometer for detecting electric currents in Radio circuits. Ruby jeweled, solid bronze, 4 inches square, fitted in a hardwood case. Also used by hunters and surveyors. Our price prepaid \$4.50 each  
**GOLD SHIELD PRODUCTS**  
 Dept. S-3, 98 Morningside Av. New York City

**FREE Books with your subscription to Short Wave and Television.**  
 See page 652

**METAL SLIDE RULES!**



4 inch diameter metal slide rule (with case). Price, prepaid, \$2.00. Equivalent scale length is about 12 inches. Performs all the regular slide rule computations. Roots, logs, sines, etc. Endorsed by colleges. Accurate, handy.  
 8-inch diameter metal. Special—large scale divisions, easy reading, equivalent scale length about 20 inches. Price, with case, \$5.00.  
**DATAPRINT CO., Lock Box 322a, Ramsey, N.J.**

**CHASSIS — CABINETS**  
**PANELS & CANS**  
**STANDARD SIZES ON HAND**  
**SPECIAL SIZES MADE TO ORDER**  
**KORROL RADIO PRODUCTS CO.**  
 Dept. S-3  
 232 Greenwich St., New York City



# Simple Laboratory Practices for Beginners

(Continued from page 629)

of showing a ground wire connecting all grounds together, *even though good practice in actual wiring calls for copper wire connections on all grounds.* Use of the ground symbol simplifies the diagram.

Draw diagrams in convenient and accepted sequence, and do not locate the parts where they physically appear. For instance, Fig. 1 and Fig. 2 are the same diagram but Fig. 1 is easy to understand and Fig. 2 is almost impossible to follow and looks like a different diagram entirely. Incidentally, Fig. 1 shows a desirable standard method of labelling all your diagrams.

**Standardization:** Your diagrams should all be the same standard size, or not more than two standard sizes so that they may be filed away. Using a large loose-leaf notebook for diagrams is a good idea. Be sure to make a new diagram or else mark changes whenever a change is made in a circuit. This will facilitate trouble-shooting. A good plan is to put a date on each diagram and keep the old diagrams as well as the new one for it is often advantageous to know how the instrument was formerly connected.

**Diagram Each Instrument:** Have a diagram for every instrument you possess. If the manufactured instruments are not supplied with diagrams—draw them yourself. Such diagrams are invaluable when something goes wrong, or you decide to make changes.

**Preparing Panel and Chassis:** When you come to the work of laying out and drilling panel and chassis, drill all holes and do all cutting first, *before* assembling and wiring. It is not only easier this way, but you avoid scratching panels or damaging delicate parts.

**Cables:** Commercial instruments are wired in the following manner. A plan, drawn to exact size, is laid out on a board with nails marking the location of various instruments. Lines of nails are driven in to guide the cables. Wires are then run to approximate terminal locations. See Fig. 3. Commercial practice for relay boards, for instance, where the wiring is apt to be complicated, is to adopt a color code. This is unnecessary for radio work which is not so complicated and does *not* run all wires in cable. However, you might adopt a simple color code for your own use. Get colored pencils for drawing the diagrams and use the same color wire—say green for grid, red for B plus, black for ground, blue for aerial, etc.

**What to Run in Cables:** Do not run R.F. wires in cable. Plate or grid wires, for instance, should be run point to point. Cable the supply wires and the A.F. wires. Cabling them will save space and add to neatness. Neatness not only pays in the satisfaction of good workmanship but its order simplifies understanding of circuits and renders changes and servicing easier. In wiring instruments such as meters, analyzers, power supplies and the like where R.F. does not enter into the consideration, use cables entirely.

**Lock Stitch:** There are two methods of lacing cables (called lock-stitching). Fig. 4 shows the single cord method. It depends upon waxed cord to keep the end

from unraveling. Fig. 5 using double cord, uses more twine but may be used with any kind of string available and is stronger. Keep the ties an even distance apart except when rounding corners, when the ties should be placed close together to hold the shape of the cable. Afterward the cable is shelled.

**Test Equipment Desirable:** It is not essential to own elaborate testing equipment in order to find trouble in radio receivers, although money spent for such equipment is not wasted because it enables you to do faster work. Such precision work as alignment should not be attempted without instruments. I know it is possible to align roughly, using a radio signal and your ears, but the reasons why you cannot rely upon this method is that the strength of received broadcast signals is always varying and our ears are not accurate scientific instruments. Take "tone controls" for example. Those simply shunting condensers across the output can be shown by the oscilloscope to simply distort the wave shape, but many radio set owners believe it "brings out the low notes." Remember the owner of a 1925 receiver who says, "The new radios don't sound half as good as my old one." I have heard that said when, to me, the sounds emitted from the set were atrocious.

## Simple Tests Without Equipment

Several simple tests can be made without instruments. Tubes can be tested by substitution—in fact, I contend there is no better test for tubes than substitution *when you use it with an output meter and signal generator.* Even without instruments, substitution tests are still good enough to find big differences in tubes.

**Testing a Dead Set Without Equipment:** In a dead set, you first place your finger on the detector control grid to test the audio amplifier and speaker. If you get a loud hum or rattle, the set is Okay from the detector back. The IF up to the control grid of the first detector in a superheterodyne may also be tested by placing your finger on the control grids.

**Testing Superheterodyne Oscillator:** The superheterodyne oscillator may be tested by listening in on another receiver (preferably a T.R.F.). To assist pickup, place the aerial wire from the T.R.F. receiver near the oscillator under test.

**Shorted Filter Condensers:** Shorted filter condensers can be found without instruments although this is a crude method. Unsolder the condensers, one by one, and turn on the set for an instant until the rectifier tube ceases to exhibit red plates.

**Testing for Voltage:** Shorting a wire from plus B to ground will tell you by presence of sparks whether any B power gets to that point. In order not to strain the apparatus too much—it is best to include a resistor in series with the shorting wire.

**Resistor and Condenser Tests:** Resistors and condensers can be tested by substitution. A decade condenser and a resistor bank greatly facilitates this work, but even this is not absolutely essential.

Please mention SHORT WAVE & TELEVISION when writing advertisers



## BY MY AMAZINGLY QUICK, EASY WAY

PREPARE Today for a Real future

Whether you are 16 or 40 years old Electricity offers you many opportunities for a well paying job or a business of your own. Here in the Coyne Shops you can get a training in 12 weeks that will qualify you for your start in this fascinating opportunity field. Coyne training is practical "Learn by doing" shop training. You don't need advanced education or previous electrical experience.



Students at COYNE operating a switchboard that controls power and light enough for a small town



No Correspondence Students testing actual converters

## Work on Actual Dynamos, Motors, etc.—Only 12 Weeks—in the Great COYNE Shops

Coyne training is not given by home study. You must come to the Coyne shops to get this training, on real actual electrical machinery and apparatus. You are trained on real Dynamos, Motors, Generators, etc., all in full operation.

## I'll Finance Your Training



Get your training first. Then take 18 months to pay for it in easy monthly payments starting 5 months after you start school. Send coupon today for all details of this plan. *H. C. Lewis*

## Earn While Learning EMPLOYMENT HELP AFTER GRADUATION

If you are short of money and need part-time work to help pay living expenses while training, my Employment Department will help you get a part-time job. After graduation they will give you Free Lifetime Employment Service.

## Here is Proof of COYNE Training

"Two weeks after leaving school I took wiring job," says E. D. Berndt, "profits paid for entire course"! You would be amazed at the number of such enthusiastic letters we receive from graduates praising COYNE results.

## Included NOW — Diesel Engines Refrigeration, Air Conditioning

This extra Training without extra cost is included with your regular training if you enroll now.

**FREE!** Send today for the Big Free Coyne book. With it I'll send you all the facts of Coyne training and special features.



FILL OUT THE COUPON and SEND it before another day of your life slips away from you!

**RUSH COUPON FOR FULL FACTS**

H. C. LEWIS, President  
COYNE ELECTRICAL SCHOOL, Chicago, Ill.  
Dept. 38-87, 500 S. Paulina St.

Dear Mr. Lewis: Send me your Big Illustrated Catalog and details of your "Pay-After-Graduation" Offer.

Name..... Street..... City..... State.....  
Age.....

20 SECONDS THAT MAY BE THE UPTURNING POINT IN YOUR LIFE!

**H. G. GISHIN'S AIR WAVE Air Scout Jr. Radios**  
**THREE-TUBE \$3.20**  
 ALL ELECTRIC  
 AIR WAVE SET  
 MODEL 3A-E

A well-designed sensitive set. Holds wonderful records for distance reception. Owners with practice able to bring in police calls, amateur, code, Transatlantic phone and broadcast transmissions.

Model 3A-E  
 Pat. No. 2,086,256

mer. Dial. Sockets, Knobs, Wire, Resistors, Condensers, and all other required parts including instructions and diagram.

**FOUR-TUBE ALL-ELECTRIC \$4.20**

MODEL 4A-E. Similar to 3A-E but with powerful additional audio stage. Four tubes, one a ballast. Speaker \$1 extra. Phones extra (see auxiliaries)

ONE-TUBE BATTERY SET—Model 1B. Satisfied owners report MARVELOUS FOREIGN RECEPTION. Also other S.W. and broadcast reception same as model 3A-E. Earphone reception. Complete kit includes parts listed above plus tube and filament rheostat. \$2.45 With Tube and Uses inexpensive batteries. . . . \$2.45 Phone (unwired)

TWO-TUBE BATTERY SET—Model 2B. Complete kit including all parts in the 1-tube model plus parts for extra audio stage including . . . \$2.95 & Phone (unwired)

THREE-TUBE DE LUXE BATTERY SET—Model 3B. Complete kit including all parts in the 1-tube model plus parts for two extra audio stages in . . . \$3.45 With Three Tubes including all three tubes. . . . \$3.45 & Phone (unwired) Following Auxiliary Parts are available: 9" x 10" meter coil (foreign) 25c; 15 to 45 meter coil (foreign) 25c; 40 to 80 meter coil (foreign) 25c; 22.5 volt "B" battery, 75c; Two flashlight "AA" batteries, 10c each; 5" Find-All Loud Speaker, \$1; Complete Antenna Kit, 50c; Wood Screw Kit, 10c. Tubes for Model 3A-E, \$1.35. Tubes for Model 4A-E, \$2.10. Long Wave Unit and Model for \$2. Double Earphones, \$1.30. Bandspread Attachment, 75c. Any model wired extra, \$1.  
 NOTE: If you already have earphones, two extra foreign coils may be substituted in any model except 4A-E.

**WORLD FAMOUS AIR WAVE 1-TUBE AIR SCOUT**

Thrilling Short Waves, Police Calls, Broadcast Programs, Amazing Results. Kit is complete except phones and battery. Uses single dry cell tube (50c) or storage bat. tube (25c). Three foreign coils 25c ea. Single Phone 25c.  
 H. G. GISHIN, CHIEF ENGINEER  
 Allied Engineering Institute, Dept. S-45  
 98 Park Place, New York, N. Y.

**U.S.W. Police Phone**

(Continued from page 613)

centage of modulation, this device insures a maximum of efficiency and provides consistent communication with the cars cruising at a distance where only momentary peaks emitted by the ordinary transmitter of this same power rating could be heard.

Sufficient audio amplification is provided in this transmitter to permit the use of a high fidelity dynamic microphone, with the result that the voice of a police radio dispatcher reaches the patrol cars with broadcast station clarity. The high-quality voice transmission thus accomplished is valuable, not merely for its pleasing effect, but for its intelligibility.

This transmitter is arranged for simplex operation on a single carrier frequency, in common with the transmitters used in the police cars, or for duplex operation involving one frequency for the headquarters transmitter and another frequency for the radio car transmitters. The voice frequency range of the new unit is 100 to 10,000 cycles within plus or minus 2db, and the harmonic distortion is confined to less than 8% rms audio harmonics.

A quartz plate is used for control, having a frequency stability of better than .025% of assigned frequency throughout a temperature range from minus 20° to plus 60° Centigrade.

The design is such that all control and audio circuits may be extended a reasonable distance for remote control. The special input circuits of this transmitter will accommodate a variety of types of microphones, such as the popular salt-shaker dynamic, the double-button carbon and the single-button handset. D.C. power-supply for carbon microphones is an incorporated feature of the transmitter and provision is also made for connection to a remote speech input telephone line. The radio frequency output circuit may be connected directly to a 70 ohm 7/8" diameter concentric transmission line for efficient feed to the antenna.

The operator in charge of this equipment knows whenever the power is on, for a red pilot-light on the face of the unit indicates that it is ready for operation. By means of a conveniently located key, he may transmit a warning tone to attract attention at the receivers and indicate that a message is about to follow. The set employs the latest type of audio frequency and radio frequency beam power tubes, and the carrier noise is 50db. down. The high ratio of output power to input power achieved through improved design accomplishes new operating economies and the safety of operating personnel is insured by an electrically dead exterior and an interior that automatically becomes dead upon removal of the cover.

Our information bureau will gladly supply manufacturers names and addresses of any items mentioned in Short Wave & Television.

**New 833 Tube**

(Continued from page 613)

outputs two of these tubes may be used in push-pull or parallel connection.

This new tube has low internal lead inductances and a terminal construction which makes bases unnecessary. The filament voltage, A.C. or D.C., is 10 volts, fil. current 10 amps.; amp. factor 35. The tube measures 8 3/4" overall. For class C telegraphy, using the tube as an R.F. amplifier and oscillator, the D.C. plate voltage is 3,000 max.; D.C. plate current 415 ma.; D.C. grid voltage -500; D.C. grid current 55 ma.; approx. driving power 20 watts; approx. power output 1000 watts.

This article has been prepared from data supplied by courtesy of the RCA Mfg. Co.

**WESTINGHOUSE UNIVERSAL MOTOR**

**\$2.55** 110 Volts AC and DC  
 Shipping Weight 3 lbs.



Specifications: 1/30 H.P. operates on either A.C. or D.C., 110 volts, 5000 R.P.M. Rheostat can be used to vary speed. Height 3 1/4", Length 3 3/4", Width 1 1/4". Shaft 1/4" one inch long. Can be used to drive Sewing Machines, Models, Buffing Laths, Polishing Head, Drills, Grindstones, etc., etc.

MOTOR only . . . . . \$2.55  
 MOTOR with Arbor and 1/4" Chuck . . . . . \$3.55  
 Add 25c for special packing and mailing anywhere in U. S. A.

**MICROPHONE and RECEIVER**

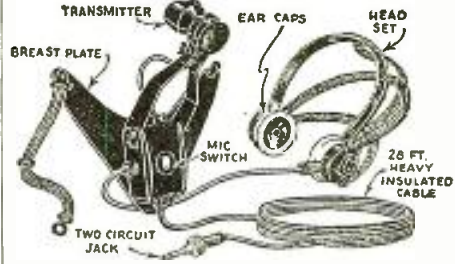

THIS Microphone and telephone headset outfit was built especially for the U. S. Navy Aviation Corps. The Holtzer-Cabot Electric Company constructed the outfit to Government specifications. The outfit consists of a low-impedance carbon microphone (transmitter), securely fastened to a metal breast-plate, and a set of heavy-duty, low-impedance earphones. A specially constructed switch on the back of the breast-plate controls the microphone circuit. The earphones are U.S.N. Utah type, attached to adjustable headband. Twenty-eight feet of very heavy weather and waterproof conductor cable is furnished. Current of not more than 10 volts should be used. A storage battery is the most satisfactory current supply. U. S. Navy Airplane-type Microphone and Receiver as described . . . . . \$4.96  
 The shipping weight is 9 lbs.  
 We will forward Shipments by Express Collect if sufficient postage is not included.

**WELLWORTH TRADING CO.**  
 560 W. Washington Blvd., Dept. SWT-338, Chicago, Ill.

**Formulas and Recipes FOR THE PRACTICAL MAN**

CONTENTS OF BOOK  
 1. Adhesives: Glues, Cements, Gums, Mucilages, Lubricants. 2. Cleansing: Stain Removers, Paint Removers, Bleaches, Cleaning Fluids. 3. Metal Craft: Coloring, Oxidizing, Plating, Repairing, Welding, Polishes, Alloys, Solders, Amalgams. 4. Paints: Colors, Stains, Varnishes, Enamels, Luminous Paint, Washable Paint; Paint-Removing, Waterproofing, Fireproofing. 5. Glass-Working: Cutting, Drilling, Boring, Bending, Blowing, Etching, Engraving, Frosting, Silvering, etc. 6. Wood-craft: Fillers, Fireproofing, Acid-proofing, Waterproofing; Furniture Polishes, Finishes, etc. 7. Inks: Recipes, Eradicators, Ink Stain Removers; Special Inks: Colored, Indelible Sympathetic, Invisible, Hectograph. 8. Photography: Developers, Emulsions, Fixers, Sensitizing, Toning, Printing, Photographic Paper, Blueprint Paper. 9. Antidotes for Poisons, Remedies for Burns and Scalds, Disinfectants, First-Aid in Accidents, Emergency Remedies, Home Remedies. 10. Preparation, Manipulation, Handling, Mixing, Measuring, Weighing, Filtering, Straining Solutions; List of Technical Substances; Emulsifying; Use of Hydrometer. Use of Thermometer; Tables of Weights and Measures, Decimal System, Useful Tables.

Price 50c Postpaid  
**TECHNIFAX**  
 Division SWT-338  
 558 W. WASHINGTON BLVD. CHICAGO, ILL.

See FREE BARTER & EXCHANGE ADVERTISEMENTS on PAGE 654

**BRILLIANT REPLACEMENT**  
 made  
**AMAZINGLY SIMPLE!**  
 Only 4 standard types of Amperite AC-DC Regulators will replace 90% (over 100 types) of AC-DC Ballast Tubes now in use!  
 WRITE FOR CHART AR.  
 New Low Price \$1.00 List  
**AMPERITE CO.** 361 BROADWAY, N. Y.  
**AMPERITE** AUTOMATIC REGULATORS

Your Guide  
**CATERPILLAR**  
 OUR 1938 RADIO PARTS CATALOG  
 CONTAINS ITEMS OF INTEREST TO RADIO AMATEURS BEGINNERS AND SERVICEMEN  
 Write for your free copy now

**CAMERADIO**  
 963 LIBERTY AVE. PITTSBURGH, PA.  
 30 TWELFTH ST. WHEELING, W. VA.  
 Established 1919

**EXPERT RADIO SERVICE COURSE**  
 Speed tough service jobs. Make more profit. The C-B Visual Service Course gives you "know how." Designed for service men by famous Midland Television School and C-B engineers. For details see C-B jobber or write us. Make your time pay more. Don't delay. Write TODAY.  
**The CLOUGH-BRENGLE CO.**  
 2813-E W. 19th St. Chicago, Ill.

## New Television Tubes

(Continued from page 613)

practical than electromagnetic, since the latter requires an extremely constant current supply, so that even the slightest line-voltage fluctuations can spoil the focus of the television picture. Also, in their opinion, electrostatic deflection is considered superior to electromagnetic, because it is necessary to introduce distortion into an electromagnetic deflection circuit to compensate for the inductance of the magnetic deflecting coils.

### TENTATIVE CHARACTERISTICS—TELEVISION C-R TUBES

TYPE	5 Inch	12 Inch
Heater Voltage	2.1	2.5
Heater Current	2.1	2.1
3d anode voltage $V_3$ max.	3000	6000
2d anode voltage $V_2$ max.	1000	2000
1st anode voltage $V_1$ max.	375	750
Grid Bias (never positive) adjusted to give suitable luminous spot.		
Standard Screen	Green*	Green*
Screen Diameter	5"	12"
Type of Deflection	Electrostatic	Electrostatic
	425	850
	$V_3$	$V_3$

Sensitivity mm/volt

### DIMENSIONS

Bulb diameter max.	5 1/16"	14"
Tube length	20"	26"

### CAPACITY

Grid to all other electrodes	10 mmf.	10 mmf.
Deflection plate to all other electrodes	11 mmf.	11 mmf.
Deflection plate and opposite plate	1 mmf.	1 mmf.

### TYPICAL OPERATING CONDITIONS

	5 Inch & 12 Inch	12 Inch Tube
3d anode voltage	3000	4500 6000
2d anode voltage	750	1125 1500
1st anode voltage	0 to 375	0 to 560 0 to 750
Grid bias	100	150 200
Grid signal, peak to peak	6	10 14

\*White Screen (at slight additional cost).

Our information bureau will gladly supply manufacturers' names and addresses of any items mentioned in SHORT WAVE AND TELEVISION.

## Automatic Radio Key

(Continued from page 613)

practically noiseless in its operation. Blank tape is automatically fed through the punching die and by the operation of the space and punch keys the call or message is punched out. Upon completion of the punching process, the tape is clipped off and ends fastened together with an adhesive, forming an endless belt, which is then transferred to the motor-driven sending mechanism on the front of the unit, where it passes through positive roller contacts, heavily silvered, which are connected to the binding posts through the key circuit switch. Operation of the driving mechanism is controlled by a motor switch and speed control.

Speed control in sending is accomplished by means of a cone with adjustable friction drive. The mechanical adjustment of sending speed has a range from ten to seventy words per minute. A further reduction, to as low as one word per minute, can be made by increasing the spacing of perforations in the sending tape.

The case is of cast aluminum, approximately five inches square by three inches in height, finished in black crackle enamel, base fitted with rubber stools. Exposed metal parts are cadmium plated.

Our information bureau will gladly supply manufacturers' names and addresses of any items mentioned in Short Wave & Television.



SOUND SYSTEMS AND EQUIPMENT
INTER-COMMUNICATION SYSTEMS
"HAM" TRANSMITTERS AND PARTS
"HAM" RECEIVERS AND SUPPLIES
TESTING INSTRUMENTS AND BOOKS
REPLACEMENT SUPPLIES AND PARTS

# Everything SOLD ON TIME PAYMENTS

Have the latest and finest radio equipment NOW and pay for it on convenient monthly terms! Send for your copy of Wards 1938 Radio Catalog—the finest ever printed. Lists everything for the Service Man, Amateur and Experimenter at rock-bottom prices. See how much you can save and how easily you can buy the radio equipment you need. Mail the coupon NOW for your FREE copy.

## MONTGOMERY WARD

MONTGOMERY WARD, DEPT. SW-4, CHICAGO, ILL.  
Please send me my FREE copy of Wards 1938 Radio Catalog. I am particularly interested in the equipment I have checked at left.

NAME .....

ADDRESS .....

CITY ..... STATE .....

## ELECTRO BROILER—Every Home Needs It!

• LATEST COOKING INNOVATION MAKES TASTIER MEALS •



A REAL cooking necessity—ELECTRO BROILER broils meat, fowl or fish—quickly and conveniently—without cooking odors. Makes food tastier by retaining all the juices and flavor—cooks by radiant heat. Simple and inexpensive to operate—use standard A.C. or D.C. current. (Convertible for toasting or broiling—can be used as electric stove.

Constructed of steel with attractive bakelite fittings—wood enameled handle permits easy handling. Complete unit—serving tray, cover with heating unit and electric cord . . . postpaid anywhere in U.S.A. **\$6.95**

Send check or money order (register letter if you send cash or stamps) to

HUDSON SPECIALTY COMPANY, 40-T West Broadway, New York, N. Y.

The Only COMPLETE Radio Library Published Today—

## RADIO-CRAFT 50c LIBRARY SERIES



THE RADIO-CRAFT LIBRARY SERIES—a most complete and authentic set of Volumes—treats individually, important divisions of radio. Each book has been designed to give you the opportunity to learn one or more branches of radio. The authors of the books are well-known to everyone. Each is an expert radio man; an authority on the subject—each is thoroughly familiar with the field which he represents.

### Here are the Titles:

- |                                    |   |                                      |
|------------------------------------|---|--------------------------------------|
| No. 2. MODERN VACUUM TUBES         | No. 8. RADIO QUESTIONS AND ANSWERS      | TION AND SERVICE                     |
| No. 3. THE SUPERHETERODYNE BOOK    | No. 9. AUTOMOBILE RADIO AND SERVICING   | No. 13. ABC OF AIR CONDITIONING      |
| No. 5. HOW TO BECOME A SERVICE MAN | No. 10. HOME RECORDING AND ALL ABOUT IT | No. 14. POCKET RADIO GUIDE           |
| No. 6. BRINGING UP TO DATE         | No. 12. PUBLIC ADDRESS INSTALLATION     | No. 15. ABC OF REFRIGERATION         |
|                                    |   | No. 17. SERVICING WITH SET ANALYZERS |

RADIO PUBLICATIONS, 99T Hudson Street, New York, N. Y. **SWT 3-38**

I have circled below the numbers of books in the RADIO-CRAFT LIBRARY SERIES which you are to send me. I have included my remittance in full, at the price of 50c each. (Stamps, checks or money orders accepted).

2 3 5 6 8 9 10 12 13 14 15 17

Name ..... Address .....

City ..... State .....

All books are sent postage prepaid

Please mention SHORT WAVE & TELEVISION when writing advertisers

## RADIO INSTRUCTION

### ALL OUT OF BOOK!

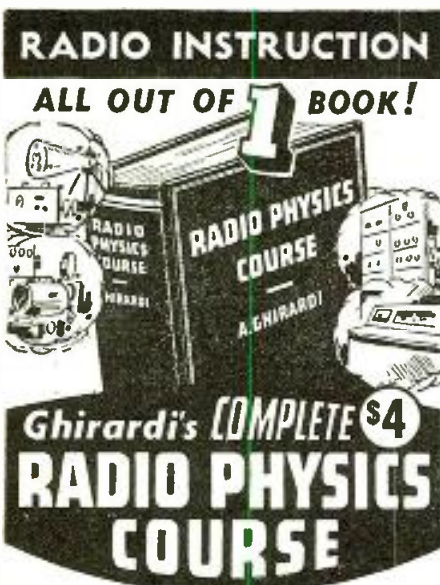

**Ghirardi's COMPLETE \$4**  
**RADIO PHYSICS COURSE**

Here's a whole radio education—ready and waiting for you between the covers of this one huge 972-page book. There's so much information in it that every single one of its 26 chapters is equivalent to a whole book of ordinary size. Comprehensive?—say, fellows, this one book will teach you everything—ELECTRICITY, RADIO, SOUND—even TELEVISION! Once you see it you'll agree that Ghirardi is a genius for getting all there is to know into such an easy-to-use volume. Written so simply that any layman can easily understand it. Freedom from unnecessary mathematics, and more than 500 clear illustrations make this the world's best, easiest and most interesting book to learn radio from.

#### WHAT YOU WILL LEARN FROM THIS BOOK!

Sound, Speech and Music . . . Electrons . . . Electric Current . . . Electric Units and Circuits . . . Resistance . . . Ohm's Law . . . Batteries . . . Magnetism . . . Electromagnetism . . . Transformers . . . Inductance . . . Condensers . . . Alternating Current Circuits . . . Filters . . . Electrical Measuring Instruments . . . Radio Waves and Radiations . . . Broadcast Stations . . . Receiving Equipment . . . Vacuum Tubes . . . Radio and Audio Frequency Amplification . . . Superheterodynes . . . Loud Speakers . . . Battery Operated Receivers . . . Power Supply Units . . . Electric Receivers . . . Automobile and Aircraft Receivers . . . Phonograph Pickups . . . P.A. Systems . . . Short-Wave Receivers . . . Photoelectric Cells . . . Television . . . Antennas and Grounds . . . Testing and Servicing Receivers . . . Sound Motion Pictures . . . Appendices . . . 656 Review Questions for Self-Study . . . AND LOTS MORE!

RADIO PHYSICS COURSE is used in the courses of more radio schools than any other radio text in the world! Both instructors and students say it's the best there is at any price! You need it too. And you get it at the amazingly low price of only \$4—with a guarantee of every penny of your money back if not fully satisfied! Don't delay—start your radio training NOW! Paste the Coupon below—**AT ONCE!** Books sent **POSTPAID** anywhere!

**LEARN RADIO IN YOUR EASY CHAIR!**  
Paste this Coupon on a Postcard—MAIL TODAY!

**RADIO & TECHNICAL PUBLISHING CO.**  
45 ASTOR PLACE • NEW YORK

- Encl. find \$4. Send my RADIO PHYSICS COURSE at once, postpaid. (Foreign \$4.50)  
 Send me a free circular describing this book.

Name \_\_\_\_\_  
St. & City \_\_\_\_\_ State \_\_\_\_\_ SW-38

**MONEY-BACK GUARANTEE!**

## LEARN CODE

*the way you'll be using it by SOUND*



There is only one way to learn to read code and that is by listening to code. There is only one way to learn to send code and that is by hearing your own sending repeated back to you. With the new all Electric Master Telex Code Teaching Machine you learn code the natural, easy, fascinating way. Only instrument ever produced which records your sending in visible dots and dashes—then SENDS BACK your own key work at any speed you desire. We furnish complete course, lend you the All Electric Master Telex, give you personal instruction with a **MONEY BACK GUARANTEE**—all at a surprisingly low cost per month. Write today for **FREE** catalog S-3. No obligation.

**TELEPLEX CO.**  
72-76 Cortlandt St.,  
New York City

## New System of Inductive Tuning and How It Works

(Continued from page 614)

be the case if end-coil (Le) were not used, and contact CT tapped a turn which represented the exact electrical center of the variable coil (LV).

We do not need to mention that it is very simple to tune this new device. All that is required is to move the contact CT, which will short-circuit more or less of the main coil and thus effect tuning of the circuit.

The most interesting detail about the new inductive tuning device is the method applied to secure *perfect contact*. The contact slider formerly used was of course out of the question for modern circuits. The problem involved has been solved by application of a little "trolley car" as shown in Fig. 2. This little car or carriage slides on a guide-rod fastened along side the coil. The distance between guide-rod and coil is relatively small and produces a firm pressure of the little rollers against the turns of the coil (see Fig. 2A). These rollers are made of an insulating material, and have no part in effecting the contact desired. Their job is to guide and move the "trolley car" precisely over the single turns of the coil.

The *actual contact* is effected by a short spring (made of an especially sturdy bronze) which is guided over the turns of the coil in a manner which is shown in Fig. 2C. Especially great care has been given to the selection of the wire used for the turns of the coil. A heavily silver plated copper wire of low resistance was chosen.

Everything else is simple. We see in Fig. 3A the customary tuning circuit with fixed inductivity—but variable capacity, and as comparison, an *inductance-tuned* circuit. The padding condenser (Pd) has been omitted in order to simplify the diagram. Fig. 3B shows methods of coupling an inductance-tuned circuit with the antenna. The use of such a circuit for interstage coupling is presented in Fig. 3C. And two circuits to be used in the oscillator stage of a superhet,

plus the circuit of a customary oscillator stage, are demonstrated in Fig. 3D.

So far we have only discussed the design and application of the new *inductively tuned* circuit, but have not mentioned the wave-range covered. As Mr. Ware explained, one coil of the design described is sufficient to cover the entire broadcast band, including the police band, without any need of switching. By application of two coils, one of normal design, and one of smaller size, the extensive wave-range from 540 kc. (555 meters) to 65 mc. (4 meters) can be covered. Both coils are rotated as shown in Fig. 2 and 4 by the same tuning knob or handle.

Of special appeal to *short-wave* fans as well as to designers of so-called "electrically tuned" receivers, is the *tuning dial*. Because of the rotating motion required to tune from one end of the tuning range to the other, a tuning dial in the form of a spiral (see Fig. 5) has been chosen as standard equipment. The length of the spiral is equal to the length of the wire used for the turns of the coil. (20-30 ft.).

In other words, this tuning dial provides—because of its enormous length, excellent possibilities for split-second tuning, without the use of complicated band-spread gadgets.

But that is not all. This faculty means super-sharp tuning without the application of AFC circuits for designers of "motor tuned" receivers. It is customary that a motor will stop within plus or minus 1/16 inch. Although 1/16 inch does not seem much to talk about, it means nevertheless 3 to 5° on the usual tuning dial, or when expressed in terms of frequencies, a tuning deviation of 2000-5000 cycles at broadcast band frequencies. Now, let us compare 1/16 inch in relation to a tuning dial with the length of 20 feet! Expressed in terms of frequency, this 1/16 inch means hardly more than 300-500 cycles, and a better adjustment than this cannot be obtained with the best of the present AFC circuits.

## A Good 5-Meter T.R.F. Receiver

(Continued from page 607)

In actual tests this receiver did very well. It received signals from all over Southern California at the listening post at Altadena, California. The only antenna was a five meter antenna 20 feet high. In addition to bringing in a large number of amateur communications, it received the voice section of W6XAO, the Los Angeles television station; very fine business!

#### Part Lists for 5-Meter Receiver

##### BUD

- 2—15 mmf. variable condensers
- 1—7x7x2 inch chassis
- 1—7x5½ inter-stage shield
- 1—7x8 crackle-finish panel
- 2—5 meter r.f. chokes

##### INSULATORS\*

- 8—5/8 inch stand-off insulators
- 1—feed-through stand-off insulator

##### SOCKETS\*

- 1—5 prong steatite socket
- 1—6 prong steatite socket
- 1—6 prong bakelite socket (audio)

##### SOLAR

- 3—.006 mf. condensers
- 2—.001 mf. condensers
- 1—.004 mf. condenser
- 2—.01 mf. tubular condensers

- 2—1 mf. tubular condensers
- 1—10 mf. 25 volts tubular condenser

##### I.R.C. (RESISTORS)

- 1—10,000 ohm resistor 5 watt
- 1—500 ohm resistor ½ watt
- 1—600 ohm resistor 5 watt
- 1—100,000 ohm resistor ½ watt
- 2—200,000 ohm resistors ½ watt
- 1—1 megohm resistor ½ watt
- 2—250,000 ohm potentiometers

##### MISCELLANEOUS\*

- 2—tip-jacks
- 1—power-supply plug
- 2—¼ inch inside diameter panel bushings
- 2—shaft extensions and shaft extension couplers
- 4—spacers, wire and screws, etc.
- 2—1¼ inch bar knobs
- 2—2¼ inch bar knobs
- 2—2 inch bakelite dial plates
- 2—3 inch bakelite dial plates

##### Coil Data

- 2 coils, 6 turns each, of No. 14 or No. 16 wire wound on a form ¾ inch inside diameter.

\*Most radio mail order houses can supply this item, if properly identified as to title of article, issue (month) of **SHORT WAVE & TELEVISION** and year.

Please mention **SHORT WAVE & TELEVISION** when writing advertisers

# RADIO INSTRUCTION

## WINS A. R. R. L. CONTEST!

**CANDLER TRAINED L. R. McDONALD**  
COPIES 60 W P M

Another contest winner proves **CANDLER** principles are essential to the handling of code at high speeds. Although McDonald had not been actively engaged in code work for ten years, he made perfect copy at 60 wpm. The Automatic Sound Consciousness Candler taught him years ago, stayed with him—proof that Candler principles are correct. Candler will do more for you in a few short weeks than months—even years—of unguided practice will do. You'll be amazed and delighted at your speed and skill when Candler helps you. Why put it off? Write today.



**FREE** 1938 BOOK OF FACTS VALUABLE CODE BOOK FOR RADIO OPERATORS

**WRITE TODAY!**

**CANDLER SYSTEM CO.**

Dept. SW-3, Asheville, N. C., U. S. A.

## LEARN CODE RIGHT

It's easy and practical to learn or improve your radio or Morse Code, any speed. Senior model with 10 tapes and Book of Instructions—\$20.25. (Rented at low cost.) Junior model with 5



tapes and Book of Instructions—\$12.00 (Not rented). Complete oscillator equipment, less battery, \$6.50. Send for details today to—  
**INSTRUCTOGRAPH CO.**  
Dept. SW-3  
912 Lakeside Place  
Chicago.  
Canadian Represent-  
ative: Radio College  
of Canada, 863 Bay  
St., Toronto

BUY ON CASH OR TERMS: HALLICRAFTER and R. M. E. SHORT-WAVE RECEIVERS, SPEED-X and VISORPLEXES

## RADIO ENGINEERING

RCA Institutes offer an intensive course of high standard engineering all phases of Radio and Television. Practical training with modern equipment at New York and Chicago schools. Also specialized courses and Home Study Courses under "No obligation" plan. Catalog Dept. SW-38.

**RCA INSTITUTES, Inc.**

A Radio Corporation of America Service

75 Varick St., New York. 1154 Merchandise Mart, Chicago

## JOBS in RADIO-TELEVISION

If you are seriously ambitious to make this fascinating, well-paying field your life work—if you have fair ability and are willing to train for success—write us. We'll tell you how we train men—how we fit them for good jobs, and help them get the jobs—how we qualify them to take exams for two Gov't. Licenses—how we prepare them for the glamorous future of television. A home-experiment course—with equipment furnished by us—followed by experience-training in our modern laboratories. The only independent school with 41-line electronic television equipment. Affiliated with Columbia basic network station KMH. Address: MIDLAND TELEVISION, INC., 112-C Power & Light Bldg., Kansas City, Mo.

## RADIO COURSES

RADIO OPERATING: Prepare for Gov't License Exam. ● RADIO SERVICING: Including Short Wave ● AMATEUR CODE ● ELECTRONICS ● TELEVISION: Day and Evening Classes. Booklet Upon Request.

**New York YMCA Schools**  
6 W. 64th Street, New York City

## A Better Code-Practice Oscillator

(Continued from page 610)

stage, but the same general circuit is used with any type of tube, by simply using the cathode circuit for keying, the grid and plate circuits for connecting in the audio transformer, and keeping the circuits of the other elements intact, just as the heater circuit is in this diagram.

You should first determine the number of prongs on the first audio tube in your radio receiver, then use a socket to fit this tube for S in figure one, and the base from a similar tube for the adapter plug D. After assembling the apparatus, you may find that it is necessary to reverse the connections on either the grid or plate winding of the transformer, in order to get the proper phase relation between these windings for oscillation.

Figure two is a drawing of one form suggested for the construction of the oscillator, with the binding posts A and B for connecting a key in series with the cathode circuit.

Figure three shows an arrangement of the oscillator for those who want the key on the same panel as the other parts for compactness.

This device may be used with excellent results in connection with a mechanical code teacher, and an added refinement may be had by using a variable resistor for R, permitting the variation of the tone of the oscillator.—J. Stewart Turner.

## Relay Made From Ford Coil

(Continued from page 610)

brass for supports, insulating fiber or heavy cardboard  $\frac{1}{2}$ " x  $\frac{1}{4}$ ", time valve spring, 1 No. 4 screw  $\frac{1}{2}$ " long.

**TOOLS.** Pliers, screw-driver, soldering iron, tap 6/32 (dime store variety) file, hack-saw, drill No. 35.

## MAKE MORE MONEY in RADIO

**CASH IN ON MY SENSATIONAL HOME TRAINING PLAN**

Actually Sets You Up For a

**PROFITABLE BUSINESS**

Be your own Boss! Get into the fast moving Radio industry. If you are an ambitious fellow, I can train you for a good paying full time or part time job . . . with a big future ahead. My training is distinctly new and different.



**No Experience Needed . . . Earn While You Learn** Sprayberry Training not only covers thoroughly all phases and branches of Radio . . . it equips you for an actual start in business. I show you how to get profitable spare time Radio service work. Moreover, I show you how to do these jobs. You gain practical experience . . . add easy cash to your bank account while learning.

### BIG PROFESSIONAL OUTFIT GIVEN!

Consists of All-Wave, All-Purpose Analyzer, Rider Manuals (7,076 pages), Tool Kit, Electric Eye Outfit, Experimental Apparatus, THE SPRAYBERRY COURSE IS SOLD UNDER AN HONORABLE MONEY-BACK AGREEMENT.

A. H. Lanoie, Northbridge, Mass., writes: "Since enrolling I have cleared a net profit of more than \$150. In spare time alone . . . and I am not half through the Course yet. Honestly, I cannot understand how you give so much dope for so little money."

### SPECIAL SERVICEMAN'S COURSE

Advanced Training for those already in Radio—teaches the easiest way to do the hardest jobs. Complete details of this advanced course and fundamental course, features, etc., fully described in my 48 page FREE book. Send for your copy today.



Mail Coupon Now

**SPRAYBERRY ACADEMY OF RADIO**  
F. L. Sprayberry, Pres.  
145-E University Place, N.W.,  
Washington, D. C.

Please send me FREE copy of "More Money in Radio."

Name  Age   
Address   
City  State   
Mail in envelope or paste coupon on Postcard.

Send for your copy TODAY

## Do You Like RADIO

TELEVISION, SOUND & ELECTRICITY

You men who want to know the true facts about employment opportunities and requirements in radio and related industries should have National's new book—40 pages of information and illustrations.

## NATIONAL SCHOOLS

### NATIONAL SCHOOLS

Dept. SWC-3, 4000 So. Figueroa St., Los Angeles, Calif.  
Please Send Free Book

NAME  AGE   
ADDRESS   
CITY  STATE

## BE A RADIO SERVICE EXPERT



Modern receivers require men with modern training for service work

### LEARN AT HOME

Our home instruction method and service equipment offer starts you earning money almost at once. Up to \$3 an hour easy in a short time. Write for free book.

**Radio Training Ass'n of America**  
Dept. SW-83  
4525 Ravenswood Ave., Chicago

## RADIO ENGINEERING

broadcasting, aviation and police radio, servicing, marine radio telephony and telephony, Morse telegraphy and railway accounting taught thoroughly. Engineering course of nine months' duration equivalent to three years of college radio work. All expenses low. Catalog free. School established 1874.

Dodge's Institute, Turner St., Valparaiso, Ind.



## Short Wave League

At a Directors Meeting held in New York City, New York, in the United States of America, the Short Wave League has elected

**John F. Müller**

a member of this League.

In Witness whereof, this certificate has been officially signed and presented to the above.

*H. W. Infield Sec'y*  
Chas. S. Conroy

This is the handsome certificate that is presented FREE to all members of the SHORT WAVE LEAGUE. The full size is 7 1/4" x 9 1/2". (See page 648.)

**Print Your Own**  
Credits, Stationery, Circuits, Advertising, etc. Save money. PRINT for OTHERS. Big profit. Junior outfit \$9; Senior Outfits \$17 and up. Easy rates sent. Write for free catalog with all details. The KELSEY Co., D-28, Meriden, Conn.

Please mention SHORT WAVE & TELEVISION when writing advertisers

# AMERICA'S MOST POPULAR RADIO BOOKS

We herewith present a selected collection of recent important radio books. We have selected these volumes because they represent the foremost radio books of their kind in print today. We publish no catalog. Order direct from this page. Prompt shipments will be made to you. Remit by money order or certified check. Register all letters containing cash.

- RADIO ENGINEERING HAND BOOK** 850 pages, latest..... **\$4.90**
- PRACTICAL TELEVISION**, 223 pages, 127 illus..... **\$3.69**
- ELEMENTS OF RADIO COMMUNICATION**, 286 pages, 241 illus..... **\$2.98**
- RADIO PHYSICS COURSE**, 992 pages, 510 illus..... **\$4.00**
- THE RADIO AMATEUR'S HANDBOOK**, 448 pages, 126 illus..... **\$1.97**
- MODERN RADIO ESSENTIALS**, over 200 pages, and over 100 illus..... **\$1.95**
- FOUNDATIONS OF RADIO**, 246 pages, 145 illus..... **\$2.47**
- PHOTOCELLS AND THEIR APPLICATION**, 332 pages, 180 illus..... **\$2.88**
- ELECTRONICS**, 134 pages, 45 illus..... **\$1.95**
- SHORT WAVE RADIO HAND BOOK**, 128 pages, 150 illus..... **\$1.00**
- PRINCIPLES OF RADIO**, 478 pages, 306 illus..... **\$3.46**
- EXPERIMENTAL RADIO**, 256 pages, 168 illus. Prepaid..... **\$2.69**
- MODERN RADIO SERVICING**, 1300 pages, over 700 illus..... **\$4.00**
- FIELD SERVICE DATA AND ANSWER BOOK**, 436 pages..... **\$2.50**
- Both Books..... **\$6.00**
- DRAKE'S CYCLOPEDIA OF RADIO AND ELECTRONICS**, 1050 pages, 1178 illus..... **\$4.88**

- FUNDAMENTALS OF RADIO**, 426 pages, Illustrated. Prepaid..... **\$3.46**
- ELECTRICITY AT HIGH PRESSURES AND FREQUENCIES**, 248 pages, 141 illus. Prepaid..... **\$1.89**
- RADIO CONSTRUCTION AND REPAIRING**, 444 pages, Illustrated..... **\$2.50**
- THEORY OF VACUUM TUBE CIRCUITS**, 226 pages, 226 illus..... **\$3.00**
- PRINCIPLES OF RADIO COMMUNICATION**, 988 pages, profusely illus..... **\$7.35**
- RADIO ENGINEERING**, 813 pages, 475 illus..... **\$5.50**
- EXPERIMENTAL RADIO ENGINEERING**, 346 pages, 250 illus..... **\$3.46**
- RADIO OPERATING QUESTIONS AND ANSWERS**, 427 pages, 106 illus..... **\$2.50**
- OFFICIAL RADIO SERVICE HANDBOOK**, over 1,000 pages, over 400 illus. Prepaid..... **\$3.92**
- OFFICIAL SHORT-WAVE RADIO MANUAL**, 240 pages, many illustrations, Vol. 1 (1934) Prepaid..... **\$2.00**
- Vol. 2 (1935) Prepaid..... **\$2.50**
- OFFICIAL RADIO SERVICE MANUAL**, Volume 4, 2,000 pages, over 400 pages Prepaid..... **\$3.43**
- OFFICIAL RADIO SERVICE MANUAL**, Volume 5, over 3,000 illus., over 1,000 pages, Prepaid..... **\$6.86**
- OFFICIAL RADIO SERVICE MANUAL**, Volume 6, over 1,200 pages, over 2,500 illus. Prepaid..... **\$6.86**

## 15 HANDY—POCKET-SIZE RADIO BOOKS

Here are 15 up-to-date books on radio and air conditioning. Modern in every sense. ALL BOOKS UNIFORM—they contain 64 pages; 50 to 120 illustrations. All books written by well-known authors. Order by Number.

2. MODERN VACUUM TUBES
3. THE SUPERHETERODYNE BOOK
5. HOW TO BECOME A SERVICE MAN
6. BRINGING ELECTRIC SETS UP TO DATE
8. RADIO QUESTIONS AND ANSWERS
9. AUTOMOBILE RADIO AND SERVICING
10. HOME RECORDING AND ALL ABOUT IT
12. PUBLIC ADDRESS INSTALLATION AND SERVICE
13. ABC OF AIR CONDITIONING
14. POCKET RADIO GUIDE
15. ABC OF REFRIGERATION
16. PRACTICAL RADIO CIRCUITS
17. SERVICING WITH SET ANALYZERS
18. POINT-TO-POINT RESISTANCE ANALYSIS
19. PRACTICAL RADIO KINKS AND SHORT CUTS

PRICE PREPAID EACH BOOK..... **50c**

### HOW TO ORDER

No C.O.D. orders. Our prices are net, as shown. Some of the books sent prepaid (in U.S. only). Those that are not thus listed are shipped collect if sufficient postage is not sent. Add 7% of price for postage.

## RADIO PUBLICATIONS, 97 HUDSON ST., NEW YORK, N. Y.



# HEY FELLOWS! 6 BACK NUMBERS OF SHORT WAVE AND TELEVISION SENT ANYWHERE IN U.S. FOR 70¢

For a limited time only, and as long as they last, we will send you six back numbers of **SHORT WAVE & TELEVISION** assorted, your choice, for 70 cents.

The usual price for six copies would be \$1.50, and most publishers charge a higher price for back numbers over one year old.

We can supply only the following back numbers: Dec. 1930; Feb., April, June, Oct., 1931; Oct., Dec., 1933; Jan., Feb., Mar., April, May, June, Aug., Sept., 1934; 1935—All issues except January and February; 1936—All issues; 1937—All issues; 1938—All issues to date.

If you do not specify copies, we will send assorted numbers to fill your order. Note, we cannot exchange the copies for ones that have been sent to you.

Every copy of **SHORT WAVE & TELEVISION** contains information which you should have. Here is a chance to get those copies.

As only a small supply of back numbers on hand, this offer will be withdrawn as soon as they have been sold.

We accept U. S. stamps, U. S. coin, or money order. Rush your order today.

**SHORT WAVE & TELEVISION**, 3-38 99-101 Hudson Street, New York, N. Y.

Gentlemen: I enclose herewith 70c. for which you are to send me six back number copies of **SHORT WAVE & TELEVISION** as follows:.....

Name.....

Address.....

City.....State.....



## FREE!! New 1938 Radio Catalog

**SERVICEMEN**—Radio Salesmen and Agents—become a **MODELL** representative in your community without any investment. Earn up to \$100 a week in commissions selling Nationally Known Radios. Take orders from the largest and most complete catalog ever published, describing and illustrating the following 1938 makes: **RCA—Philco—General Electric—Zenith—Motorola—Delco—Grunow—Crosley—Stromberg—Carlson—Kadette—Emerson**. Join our nation wide organization. Territory is now being allotted to live wire men who are anxious to earn extra money in their spare time. Write for this big catalog and selling proposition today. No experience necessary.

**Modell's** Since 1889

AGENCY DIVISION—DEPT. L-5  
CHICAGO, ILL. 56 W. Washington St. ATLANTA, GA. NEW YORK, N.Y. 57 Forsyth St. 58 Cortlandt St.

Please mention **SHORT WAVE & TELEVISION** when writing advertisers

## CBS Station W2XE In Action!

(Continued from page 630)

system operates at a pressure of 50 to 55 pounds. All apparatus composing the cooling system is located in the basement, under the new transmitter. When the filaments of the water-cooled tubes are disconnected from the source of power, the water pump is also stopped. The water in the entire cooling system then returns to the copper storage tank. The water cooler consists of a large blower or fan and radiator. The water is forced through the cells forming the radiator. The large fan drives cool air, brought in from the outside, through these water-filled cells, and in this way the temperature of the circulating water is reduced. The warm air leaving the blower is discharged outside the building by means of ducts.

The power of the W2XE transmitter is 10 kw., and two sets of directional antennas are employed, one for European listeners during the day, and the other for Central and South American audiences after 5:30 p.m., E.S.T. Besides the transmitting frequencies mentioned in one of the captions, W2XE is also licensed for additional frequencies of 6120 and 17760 kc.

## BOOK REVIEW

**TELEVISION CYCLOPEDIA** by Alfred T. Witts. Cloth covers, size 5 1/2"x8 1/2", 152 pages, illustrated. Published by D. Van Nostrand Co., N. Y.

A very handy manual for the television student, in which all the modern terms used in connection with television transmitters and receivers are listed alphabetically. Wherever necessary a diagram or sketch is given with a clearly written text description of the part or function.

Among the interesting and important topics we find alphabetically catalogued and described are:—Accelerating Lenses, Aperture Distortion, Cathode Ray Tube, Dark Current, Deflector Plate Impedance, Electro-Magnetic Focusing, Electron Multiplier, Electro-Static Focusing, Farnsworth Camera, Iconoscope, Image Dissector, Intermediate Record System, Kerr Cell, Mirror Screw, etc.

**TELEVISION—The Future of the New Art and Its Recent Technical Developments. Vol. 2.** Stiff paper covers; size 6"x9"; 436 pages; illustrated with line drawings and half-tones. Published by RCA Institute Technical Press, New York.

Every real student of television should have a copy of this valuable treatise, which contains papers by many of the leading television engineers, including such names as Goldsmith, Beal, Engstrom, Zworykin. Some of the important chapters show with photos and diagrams the experiments carried on by RCA; the famous Empire State Building transmitter in New York City is illustrated and described.

One chapter covers long-distance television signal field-strength measurements. Studio facilities for television and studio design are discussed and illustrated, and then we come to such important subjects as television and the electron oscillograph for television developments, with circuits, a chapter on the kinescope and how it works, the analysis and design of video amplifiers, etc. A mathematical analysis of cathode ray tube action, including its limitations, is given, also a discussion of outdoor television pick-ups, the iconoscope and how it works, etc. Several closing chapters of the utmost importance to every student of television cover the projection kinescope, high current electron gun for projection, kinescopes, television pick-up tubes, cathode ray tube screens (mathematically and chemically considered), and a very good chapter covering the electron optics of an image tube.

## 300 Watts Out of a T-125

(Continued from page 625)

tion. Make sure that the condenser you use is large enough to permit complete neutralization with sufficient spacing between the plates to withstand the high R.F. voltage appearing across it during modulation peaks. This particular unit has 2 13/16 inch diameter plates and is just right for the job.

### Two Meters Used

There are two meters for checking the grid and plate current. These meters are mounted on the panel, one above the other. The grid meter has a 0-100 ma. scale while the plate meter has a scale of 0-250 ma. Nearly all of the other equipment is located above the chassis. Although the photos do not show it, the only parts below the chassis are the two filament by-pass condensers, the grid by-pass condenser and the grid-leak resistor.

We have used *parallel-feed* in the grid circuit in order to simplify matters and permit the grid condenser frame to be grounded to the chassis. The use of parallel feed does not affect operation in the least, and does away with insulating bushings or stand-offs which would otherwise be necessary. If they are used in mounting the grid condenser, they would also have to be used with the plate condenser in order to make both units the same height for neat panel appearance. Since the stator or frame of the plate condenser is normally at zero potential it can be connected directly to the chassis. If a condenser with less spacing between plates is used, it is advisable to insulate it from the chassis because if there should be an R.F. arc-over, this arc would form a ready path for the high voltage D.C. and cause no end of damage. But, where the condenser spacing is great enough to eliminate all danger of a flash-over it is perfectly safe to ground the rotor.

### Grid Bias

The recommended grip bias for class "C" operation is approximately 200 volts. This bias may be obtained from batteries or a grid resistor or a combination of both. In our case we used the resistor method, but it is advised that the combination be used for safety. Ninety volts of battery bias with a 2000 ohm resistor would provide the best arrangement. This would permit the plate current to fall to fairly low value in

case of excitation failure and thus prevent damage to the tube. During operation a grid current of 60 milliamperes provides good linearity when the amplifier is modulated. This means that the excitation amounts to approximately 20 watts. For CW operation less excitation power is required, of course; 10 to 15 watts should be sufficient.

The fairly modest driving power requirements of the T-125 makes it an exceptionally desirable tube. A single 807 of the newer type will provide ample driving power. In fact this amplifier will work very efficiently with the "Band Switching Exciter" described in the February issue.

### Parts List

#### BUD

- 1—100 mmf. split stator cond. .200" spacing (No. 98)
- 1—100 mmf. variable cond. .100" spacing, (No. 63)
- 1—No. 893 neutralizing con. (see text)
- 1—No. 226 tube socket
- 2—No. 568 RF choke 2.8 mh.
- 4—No. 811 jack type stand-off insul.
- 15—No. 812 plugs for coils
- 2—No. 715 4 in. dials

#### AEROVOX

- 4—.001 mf. 1000 V. mica conds.
- 2—.001 mf. 5000 V. mica conds.
- 1—4000 ohm 50 watt resistor

#### TRIPLETT

- 1—0-250 ma. meter
- 1—0-100 ma. meter

#### TUBES

- 1—T-125 tube\*

#### PAR-METAL

- 1—17x13x2 in. chassis

### Coil Data (Plate)

- 80 M. 32 turns
- 40 M. 20 turns
- 20 M. 10 turns

The above are wound with No. 12 enam. wire. Diameter, 2 1/2 in. Length of winding, 5 1/4 in.

### Coil Data (Grid)

- 80 M. 30 turns No. 12, Dia. 2 1/2 in. Length winding 3 3/4 in.
- 40 M. 20 turns No. 12, Dia. 2 1/4 in. Length winding 3 in.
- 20 M. 10 turns No. 12, Dia. 2 1/4 in. Length winding 3 1/4 in.

All link coils for the grid are two turns. The links for the plate are of the number of turns to provide proper load, if a low impedance antenna feeder-system is used.

\*Most radio mail order houses can supply this item if properly identified as to title of article, issue (month) of SHORT WAVE & TELEVISION and year.

## A 441-Line Cathode-Ray Television Receiver

(Continued from page 606)

parts of the receiver usually necessitates two or more distinct power-supply units.

The synchronizing system which permits stable images to be seen requires some consideration, as this—above all other defects in a system—is most annoying to a "viewer."

### Cathode-Ray Section

And last but not least, the cathode-ray tube section of the receiver requires careful selection of parts to supply the voltages to the several anodes of the C.-R. tube, and the sweep circuits, either electrostatic or electromagnet, which ever the tube manufacturer decides is best for his tube, must be very carefully designed and constructed to give the straight unwavering motion of the ray beam back and forth and up and down thus forming the background oblong of subdued light upon which the dancing figures, singers, bands, speakers and isometric patterns which constitute television programs today, are built.

With these points in mind—and many more which have not been mentioned, the reader will be better able to understand the unusual design of the set which we will describe in the next few issues of *Short Wave and Television*. The set, its power-supply and the C.-R. circuits will be quite different from conventional circuits in many ways.

For the interest of those who may be curious as to the appearance of the set, an artist's sketch is shown, with the three chassis, the lowest being the power-supply, the second the receiver and the top the cathode-ray tube and sweep circuits.

The general layout of the parts in the set is shown in the block diagram which places the main functions of the set where they are located in the operation of the set.

In part II of this constructional series, the actual construction of the receiver chassis will be given, with a list of the parts used, the circuit and photos of the model.

**FOR TOUGH JOBS!**

"The 'Super-Pro' has certainly proved itself a gem on my toughest expedition assignments. It is a grand set and I wouldn't be without it at any time," says Len Hammond, Fox Movietone News. Mail coupon below for "38" catalog with complete "Super-Pro" details.

Hammarlund Mfg. Co., Inc. SWT 3-38  
424-438 W. 33rd St., N. Y. C.

Please send me "38" catalog.  
 Please send me "Super-Pro" Bulletin.

Name .....

Address .....

City ..... State .....

**HAMMARLUND**

Canadian Address: 41 West Ave., No., Hamilton, Ontario

For HUM-PROOF-TROUBLE-PROOF Operation

**TYPE TL**

**DYKANOL Filter CAPACITORS**

SINCE Type TL filter capacitors were introduced three years ago, they have become extremely popular with "hams" and S-W fans throughout the country. These DYKANOL capacitors, in common with all Cornell-Dubilier condensers, are noted for their rugged dependability.

They are DYKANOL impregnated and filled in hermetically sealed round aluminum containers with standard stud and bolt mounting. Designed to produce neat symmetrical jobs, dependable in operation and simple to hook up. Available in a complete capacity range at voltages from 600 to 1500 volts. For real filtering the year round specify Cornell-Dubilier Type TL capacitors. Described in complete detail in Catalog 151A free on request. Write to:

1027 Hamilton Blvd. So. Plainfield, N. J.

**CORNELL - DUBILIER**

ELECTRIC CORPORATION

South Plainfield, New Jersey

Please mention SHORT WAVE & TELEVISION when writing advertisers

# Once in a Lifetime WE CELEBRATE RADIO'S GOLDEN JUBILEE

## 50 Years of Radio Progress

Will Be Depicted in  
**MARCH '38 RADIO-CRAFT—**

# JUBILEE SOUVENIR NUMBER

**Here are the highlights:**

- Story of Amateur Radio • Progress of Radio Receivers • Grand Old Men of Radio
- Radio Parts of Yesteryear • Early Forecasts and Their Fulfillment • Car-Radio Sets—From 1901!
- Chronological History of Radio • Reminiscences of Old-Timers • From Fleming Valves and Up
- Good Old Set-Building Days • Famous Circuits in Radio History • Famous Radio Stations • Special Old Timers' Page • Feature Radio Articles • and many more sensational articles to bring fond memories—

**And here are more features:**

- MORE THAN DOUBLE THE USUAL NUMBER OF PAGES • COVER ATTRACTIVELY PRINTED IN FOUR COLORS AND GOLD • SPECIAL, NEW COVER AND BODY PAPER • HUNDREDS OF OLD TIME DIAGRAMMS, CIRCUITS, PHOTOS—EQUIPMENT YOU'VE NEVER SEEN BEFORE
- EVERY NEW ADVERTISEMENT WILL BE ACCOMPANIED BY THE REPRODUCTION OF AN OLD ONE—GREATEST THING YOU EVER SAW! • DIFFERENT FROM ANYTHING EVER PUBLISHED IN A RADIO MAGAZINE • NEWSSTAND PRICE—50c A COPY

*No Additional Cost to Regular Mail Subscribers*

## Look for the GOLD COVER on the JUBILEE SOUVENIR NUMBER

**MARCH 1938 RADIO-CRAFT - - - - NOW ON ALL NEWSSTANDS**

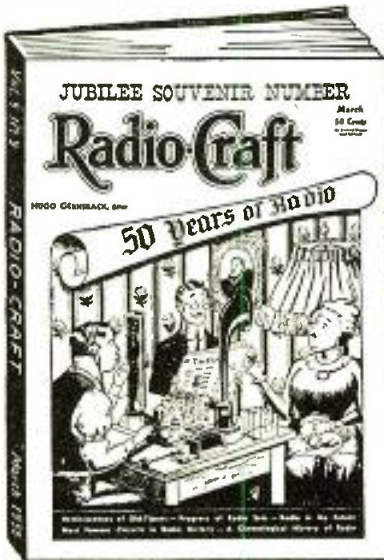

144 PAGES

## Power-Supply and Modulator for H-G-M Xmitter

(Continued from page 627)

### List of Parts

#### UNITED TRANSFORMER COMPANY (Transformers)

- 1—PA 116 high voltage transformer
- 1—PA111 low voltage transformer
- 1—PA33X filament transformer
- 1—PA29 filament transformer
- 1—PA34 filament transformer
- 1—PA102 high voltage choke
- 1—PA103 low voltage input choke
- 1—PA41 low voltage filter choke
- 1—PA28 modulator power transformer
- 1—PA105 modulator input choke
- 1—PA44 modulator filter choke
- 1—VM2 modulation transformer
- 1—PA52X modulation input transformer

#### CORNELL-DUBILIER (Fixed Condensers)

- 3—20 mf. 35 V. electrolytics
- 3—0.5 mf. paper condensers
- 2—0.1 mf. paper condensers
- 1—0.05 mf. mica condenser
- 2—double 8 mf. 525 V. electrolytics
- 2—1000 V. oil filled condensers; 2 mf.
- 2—1500 V. oil filled condensers; 2 mf.

#### I. R. C. (Resistors)

- 2—100 ohm. 1 W. resistors
- 1—800 ohm. 1 W. resistor
- 2—5 meg. 1/2 W. resistors
- 1—1500 ohm 1/2 W. resistor
- 1—2000 ohm 1/2 W. resistor
- 1—25 meg. 1/2 W. resistor
- 1—50,000 ohm 1/2 W. resistor
- 1—1 meg. 1/2 W. resistor
- 1—125 ohm wire wound 20 W.
- 1—15,000 ohm wire-wound 10 W.
- 1—4,000 ohm wire-wound 10 W.
- 1—50,000 ohm wire-wound 25 W.
- 1—2,000 ohm wire-wound 20 W.
- 1—20,000 ohm wire-wound 100 W.
- 1—50,000 ohm wire-wound 100 W.
- 1—20,000 ohm wire-wound 200 W.
- 1—60,000 ohm wire-wound 200 W.

#### RAYTHEON (Tubes)

- 2—866 A rectifiers; 1—5Z8; 1—8S.
- 4—6L6; 1—6N7; 1—6J7; 1—6C5.

#### BUD

(Rack and panel sections, sockets, plugs, etc.)

- 1—No. 1256A panel with rack sections to fit (12 1/4" high)
- 1—No. 1254A panel with rack section to fit (8 3/4" high)
- 1—No. 1253A panel with rack section to fit (7" high)
- 2—No. 659 chassis
- 1—692 bottom plate
- 2—pairs No. 459 side brackets
- 1—No. 282 phone plug
- 7—octal wafer sockets
- 6—4 prong No. 264 sockets
- 4—7 prong No. 267 sockets

- 2—5 prong No. 265 sockets
- 4—plugs No. 314; 2—plugs No. 291
- 6—lug strips
- 5—No. 1007 toggle switches

#### METERS\*

- 1—15 V. A.C. voltmeter
- 1—2000 V. D.C. voltmeter
- 1—300 ma. milliammeter

#### MISCELLANEOUS\*

- 1—45 volt battery (C Bias)
- \*Most radio mail order houses can supply this item if properly identified as to title of article, issue (month) of SHORT WAVE & TELEVISION and year.

## All-Wave Super-Six

(Continued from page 609)

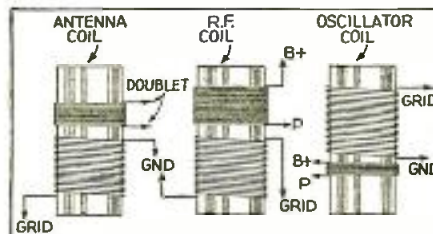

		COIL DATA			
RANGE		ANT. COIL	R.F. COIL	OSC. COIL	TYPE OF WIRE & SPACING.
16-55 METERS	PRIMARY	32 TURNS	62 TURNS	7 TURNS	No. 20 SPACED 3/16" 7/8" FORM.
	SECONDARY	10 TURNS	10 1/2 TURNS	10 3/8 TURNS	
8-25 METERS	PRIMARY	6 TURNS		4.3 TURNS	No. 30 INTER-WOUND.
	SECONDARY	2.7 TURNS		2.7 TURNS	

Coil Data for Super-Six

#### LOUD-SPEAKER

6" P.M. Electro-Dynamic speaker (7000 ohms for 33 and 14,000 ohms for 1F4)—mount on large flat baffle.

#### ALADDIN OR MEISSNER

2—triple tuned I.F. transformers (see text)

#### MISCELLANEOUS

- 0.3 volt voltmeter and 3 ohm rheostat with switch
- An audio transformer or 800 henry choke
- 3—B batteries and a C battery (or power-pack)
- 1—A battery (4 dry cells, air-cell battery, or storage cell)
- 5—pen flashlight cells
- Padding condenser (see text)

The data on the 16-55 meter coil is included for those who may wish to construct them in preference to purchasing them. All windings are in the same direction. On the broadcast coil, ground the end of the primary that does not have the capacity winding on it. The primary to the high frequency Ant. coil should be connected to the Ant. directly from the coil. In the original it was just a loose coil that was slipped in the form when needed.

Please mention SHORT WAVE & TELEVISION when writing advertisers



# Television Sweep Coil Data

(Concluded from last issue)

● CONTROLS are provided so that the circuit can be adjusted for optimum operation. The speed controls,  $R_1$  and  $R_2$ , form a variable grid-leak resistance for the left-hand triode unit, the blocking-oscillator triode. The setting of these controls determines how fast the blocking charge can leak off from the grid condenser  $C_1$ . The setting should be made so that the synchronizing signal has control of the frequency with which the left-hand triode unit alternately blocks and oscillates. Incorrect adjustment of  $R_1$  and  $R_2$  is indicated by vertical drifting of the picture.

The picture-size control  $R_3$  is a variable plate resistor for the right-hand triode unit of the 6N7. The setting of this control determines how much decrease in plate voltage occurs on the positive pulses of grid voltage. The setting of the control, therefore, determines the amplitude of the sawtooth variations in plate voltage, and thus determines the height of the picture.

The peaking control  $R_4$  is used to control the waveform of the current in the deflecting coils. The resistance of  $R_4$ , in conjunction with the condenser  $C_3$ , has a distorting effect on waveform which is opposite to the distorting effect produced by the resistance and inductance of the deflecting coils.

By adjustment of  $R_6$  it is possible to compensate, to a large degree, for the waveform distortion produced by the deflecting coils.

The distribution control  $R_5$  is a potentiometer for adjusting the grid bias on the 6C5 to a value such that the increases in deflecting current are made approximately linear with respect to time. These increases should be linear, of course, because the spot should move down the screen with uniform speed. The necessity for the control  $R_5$  arises because the increases in plate voltage of the right-hand triode unit are not linear with time. Instead, these increases follow an exponential condenser-charging curve. The curvature of this charging curve is opposite to the curvature of the dynamic characteristic of the 6C5. The curvature of the 6C5 characteristic can, therefore, be made to compensate for the curvature of the charging curve. By means of this compensation, the increases in deflecting current can be made substantially linear with time.

The centering control  $R_{10}$  provides a steady d-c current, of controllable polarity and magnitude, in the deflecting coils. By adjustment of this control, the picture can be shifted up and down on the viewing screen.

The feedback transformer T should have a primary and secondary of low inductance and low distributed capacitance. With low inductance and low capacitance in this transformer, the left-hand triode unit, when it starts to oscillate, oscillates at a high frequency. It is desirable that this frequency should be high because it is desirable to have a short period of oscillation in order to make the return portion of the deflecting cycle short.

The synchronizing signal should be strong enough so that it has positive control of the blocking-oscillator triode. This requirement is met by a synchronizing signal having a peak amplitude of about 20 volts.

A typical horizontal-deflecting circuit is shown in Fig. 3. In this circuit, a 6N7 and an output stage generate a synchronized, sawtooth current in a manner similar to that described for the vertical-deflecting circuit. However, the horizontal-deflecting circuit must, of course, operate at a much higher frequency than the vertical-deflecting circuit. Because the horizontal-deflecting frequency is high, the deflecting current decreases very rapidly on the return portion of the deflecting cycle. This rapid decrease in current causes shock-excited oscillations in the plate circuit of the output stage. To damp out these oscillations, a type 1-v tube is connected across the primary of the output transformer  $T_2$ . When oscillation starts, the primary first swings the cathode of the 1-v to a high positive voltage, and then swings it negative. As soon as the primary swings the cathode negative with respect to the plate of the 1-v, the 1-v conducts current. Thus, the 1-v quickly damps out the oscillation.

At the start of the oscillation, the upper end of the primary may rise to a very large positive voltage. This voltage is impressed on the plate of the 42 as well as on the cathode of the 1-v. Because this voltage is much higher than the maximum value for which the 42 and 1-v are rated, some tubes may have a short life in this circuit. It is suggested that the heater of the 1-v be operated at 4 volts instead of at the rated value of 6.3 volts in order to reduce the temperature of the insulation in the tube and thus enable the tube to withstand better the high inverse voltage.

FIG-1 VOLTAGE-SUPPLY CIRCUIT FOR RCA-1800-9 TUBE.

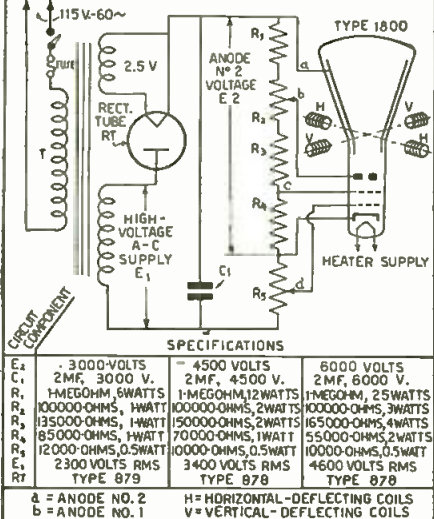
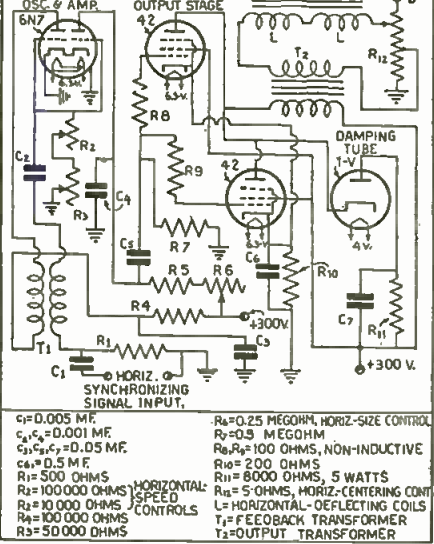

FIG.3 HORIZONTAL-DEFLECTING CIRCUIT - 9 TUBE.



# FOR THOSE WHO WANT The Best



## THE WORLD'S FINEST RADIO

Only a custom, laboratory built radio can give the sensational performance of a SCOTT! Features currently new in many factory, mass-produced receivers were offered in a SCOTT years ago! So far advanced in design, and so perfect are the materials and hand craftsmanship in a SCOTT that it is guaranteed for 5 years! Distance?—The SCOTT holds 6 official world's records. Tone?—Finer than the costliest motion picture sound system. Power?—World's most powerful radio. You will be amazed at the spectacular ability and moderate cost of this hand-made, precision instrument.

### MAIL COUPON FOR SPECIAL OFFER!

Own the guaranteed finest in Radio... a SCOTT! 30-day free trial in your own home, and Budget Plan, anywhere in U.S.A. Laboratory built on order only. NOT SOLD THRU STORES. Send the coupon for all the facts.



E. H. Scott Radio Labs., Inc.  
 4470 Ravenswood Ave.,  
 Dept. 28C8 Chicago, Ill.

Name .....

Address .....

STUDIOS: CHICAGO, NEW YORK, LOS ANGELES, LONDON

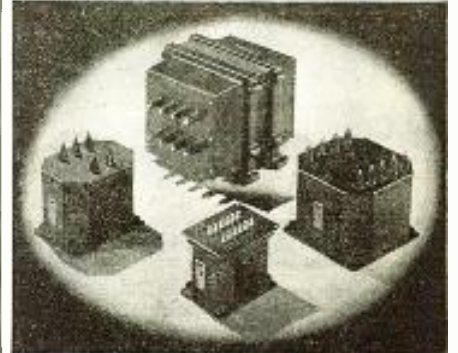

# UTC VARIMATCH Modulation Transformers will match ANY Modulator Tubes to ANY RF Load . . .

VM-0	Maximum audio output 20 watts. Net	\$ 3.00
VM-1	Maximum audio output 30 watts. Net	4.80
VM-2	Maximum audio output 60 watts. Net	7.50
VM-3	Maximum audio output 125 watts. Net	12.00
VM-4	Maximum audio output 300 watts. Net	19.50
VM-5	Maximum audio output 600 watts. Net	42.00

### Varimatch Never Becomes Obsolete

See your local jobber for the new UTC Varimatch Bulletin and the new PS-402 catalog listing the most complete line of radio transformers in the world.

# UNITED TRANSFORMER CORPORATION

72 SPRING STREET NEW YORK, N. Y.

# All about the SHORT WAVE LEAGUE

## A FEW WORDS AS TO THE PURPOSE OF THE LEAGUE

The **SHORT WAVE LEAGUE** was founded in 1930. Honorary Directors are as follows:

Dr. Lee de Forest, John L. Reinartz, D. E. Replogle, Hollis Baird, E. T. Somerset, Baron Manfred von Ardenne, Hugo Gernsback, Executive Secretary.

The **SHORT WAVE LEAGUE** is a scientific membership organization for the promotion of the short wave art. There are no dues, no fees, no initiations, in connection with the **LEAGUE**. No one makes any money from it; no one derives any salary. The only income which the **LEAGUE** has is from its short wave essentials. A pamphlet setting forth the **LEAGUE'S** numerous aspirations and purposes will be sent to anyone on receipt of a 3c stamp to cover postage.

## FREE MEMBERSHIP CERTIFICATE

As soon as you are enrolled as a member, a beautiful certificate with the **LEAGUE'S** seal will be sent to you, providing 10c in stamps or coin is sent for mailing charges.

Members are entitled to preferential discounts when buying radio merchandise from numerous firms who have agreed to allow lower prices to all **SHORT WAVE LEAGUE** members.

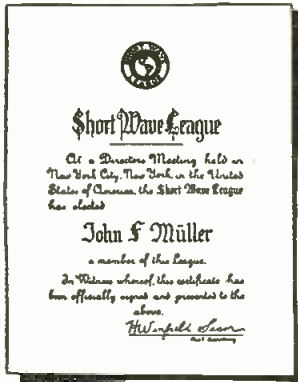

If you wish your name engraved on the Free membership certificate, as illustrated above, please send 25c to cover cost.

### SHORT WAVE ESSENTIALS LISTED IN OPPOSITE COLUMN SOLD ONLY TO SHORT WAVE LEAGUE MEMBERS

They cannot be bought by anyone unless he has already enrolled as one of the members of the **SHORT WAVE LEAGUE** or signs the blank below (which automatically enrolls him as a member, always provided that he is a short wave experimenter, a short wave fan, radio engineer, radio student, etc.).

Inasmuch as the **LEAGUE** is international, it makes no difference whether you are a citizen of the United States or any other country. The **LEAGUE** is open to all.

## Application for Membership SHORT WAVE LEAGUE

**SHORT WAVE LEAGUE.** 3-38  
99-101 Hudson Street, New York, N. Y.

I, the undersigned, herewith desire to apply for membership in the **SHORT WAVE LEAGUE**. In joining the **LEAGUE** I understand that I am not assessed for membership and that there are no dues and no fees of any kind. I pledge myself to abide by all the rules and regulations of the **SHORT WAVE LEAGUE**, which rules you are to send to me on receipt of this application.

I consider myself belonging to the following class (put an X in correct space): Short Wave Experimenter  Short Wave Fan  Radio Engineer  Student

I own the following radio equipment:

Transmitting .....

Call Letters .....

Receiving .....

Name .....

Address .....

City and State .....

Country .....

I enclose 10c for postage and handling for my Membership Certificate.

The speed control, size control, and centering control in this circuit are similar to the controls in the vertical-deflecting circuit. The horizontal-centering control requires a current in the order of 300 milliamperes. The reason this control requires much more current than the vertical-centering control is that the horizontal-deflecting coils have fewer turns than the vertical-deflecting coils and, therefore, require more current for full deflection of the beam. A simple way to obtain the large current required for the horizontal-centering control is to use a control of small resistance connected, as shown in the diagram, in series with the B— return to the power pack. With the control connected in this way, the entire d-c output current of the power pack can be made to flow through the control. The B— connection of the control resistance should be made, of course, to a point in the power-supply filter that will give sufficient filtering of the current in the control.

The feedback transformer  $T_1$ , as in the case of the vertical-deflecting circuit, should have a primary and secondary of low inductance and low distributed capacitance. A peak amplitude of about 20 volts or more.

The output transformer  $T_2$  should be designed for frequency range between the fundamental frequency of the deflecting current, about 13,000 cycles, and the highest harmonic important in the sawtooth waveform of deflecting current, about 100,000 cycles. The turns ratio can be 1 to 1 if the yoke shown in Fig. 4 is used; if the yoke of Fig. 5 is used,  $T_2$  should have a 5 to 1 stepdown turns ratio.

The values of  $C_0$  and  $R_0$  are somewhat critical and depend on the design of the transformer  $T_2$ . For some transformer designs, the optimum values may be different from those shown in the diagram.

This data refers to Fig. 1, diagram of voltage supply circuit for the 5" dia. No. 1801, Cathode tube.

- a—Anode No. 2
- b—Anode No. 1
- c—Grid
- h—Horizontal-deflecting coils
- v—Vertical-deflecting coils
- t—Power Transformer
- C1—2 mf. 2,000 V.
- R1—1.0 megohm, 3 watts
- R2—100,000 ohms, 1.0 watt
- R3—150,000 ohms, 0.5 watt
- R4—15,000 ohms, 0.5 watt

This data refers to Fig. 2, vertical-deflecting circuit.

- C1, C3—0.1 mf.
- C2, C4—0.25 mf.
- C5, C6—10 mf.
- R1—200,000 ohms
- R2—10,000 ohms
- R3—100,000 ohms
- R4—2 megohms
- R5—2 megohms—Vertical size control
- R6—100,000 ohms, vertical peaking control
- R7—1 megohm
- R8—100,000 ohms, vertical-distribution control
- R9—10,000 ohms
- R10—50,000 ohms, vertical-centering control
- R11—50,000 ohms
- L1—Coupling choke, 100 henries
- L2—Vertical-deflecting coils
- T—Feedback transformer

Fig. 3, diagram has the following constants:

- C1—0.005 mf.
- C2, C4—0.001 mf.
- C3, C5, C7—0.05 mf.
- C6—0.5 mf.
- R1—500 ohms

# Accessories for Members of the SHORT WAVE LEAGUE

Every member of the **SHORT WAVE LEAGUE** wants to identify himself in some way. For your convenience the League directors have prepared suitable letterheads, label buttons, stickers, etc. In addition there are many short-wave accessories, such as maps, globes, etc., which the League offers only to members at special prices. Take your choice from this advertisement. **THESE ESSENTIALS ARE SOLD ONLY TO LEAGUE MEMBERS.**



### LEAGUE LETTERHEADS

A beautiful, official letterhead has been designed for members' correspondence. The letterhead is invaluable when it becomes necessary to deal with the radio industry, mail order houses and radio manufacturers, as many houses offer members of the **LEAGUE** preferential discount. The letterhead is also absolutely essential when writing for verification to radio stations either here or abroad, as it automatically gives you a professional standing.

A—SHORT WAVE LEAGUE letterheads, 50c per 100

A—50c per 100

### WORLD GLOBE

This important essential is an ornament for every desk or study. It is a globe, 6 in. in diameter, printed in fifteen colors, glazed in such a way that it can be washed. This globe helps you to intelligently log foreign stations. The base is of solid wood, which has an attractive appearance to every station, emphasizing the long-distance work of the operator.



D—Globe of the World 89c

D—89c each

### SHORT WAVE MAP OF THE WORLD

This beautiful map, measuring 18x26 in. and printed in 18 colors is indispensable when hung in sight or placed under the glass on the table or wall of the short wave enthusiast. It contains a wealth of information such as distances to all parts of the world, political nature of the country in which a broadcast station is located, etc., and from the manner in which the map is blocked off gives the time in different parts of the world at a glance.



F—SHORT WAVE Map of the World, 25c

### WORLD RADIO MAP AND STATION FINDER

The finest device of its kind published. The world's map on heavy board is divided into 23 sections, while the rotary disc shows you immediately the broadcast time in any foreign country. Invaluable in logging foreign stations. Also gives call letters assigned to all nations. Size 11"x22".



C—Radio Map of the World and Station Finder, 25c

C—25c each

### LEAGUE LABEL BUTTON



E—35c each

This beautiful button is made in hard enamel in four colors, red, white, blue and gold. It measures three quarters of an inch in diameter. By wearing this button, other members will recognize you and it will give you a professional air. Made in bronze, gold filled, not plated. Must be seen to be appreciated.

G—SHORT WAVE LEAGUE label button, 35c

EE—SHORT WAVE LEAGUE label button, like the one described above but in solid gold, 2.00

### SHORT WAVE LEAGUE

99-101 Hudson St., New York, N. Y.

**SHORT WAVE LEAGUE.** 3-38  
99-101 Hudson Street, New York, N. Y. Gentlemen.

I am a member of the **SHORT WAVE LEAGUE**

Please send me application for membership in the **SHORT WAVE LEAGUE**

Please send me the following short wave essentials as listed in this advertisement:

.....

.....

.....

.....

.....

.....

.....

.....

.....

.....

.....

.....

.....

Please mention **SHORT WAVE & TELEVISION** when writing advertisers

- R<sub>1</sub>—100000 ohms
- R<sub>2</sub>—10000 ohms
- R<sub>3</sub>—100000 ohms
- R<sub>4</sub>—50000 ohms
- R<sub>5</sub>—0.25 megohm, horizontal-size control
- R<sub>6</sub>—0.5 megohm
- R<sub>7</sub>—400 ohms
- R<sub>8</sub>—8000 ohms, 5 watts
- R<sub>9</sub>—5 ohms, horizontal-centering control
- L—Horizontal-deflecting coils
- T<sub>1</sub>—Feedback transformer
- T<sub>2</sub>—Output transformer

The coils are wound flat (See Figs. 6A and 6B), are impregnated, and are removed from the winding form. They are then heated, are bent to fit in the cylindrical form of the yoke, and are allowed to cool in this form. The two horizontal-deflecting coils are each made up of 6 rectangular sections. The three smallest sections are of 10 turns each; the other three sections are of 20 turns each. All six sections are random-wound of No. 26 enameled copper wire. The two vertical-deflecting coils are each made up of 8 rectangular sections. The four smallest sections are of 700 turns each; the other four sections are of 750 turns each. All eight sections are random-wound of No. 38 enameled copper wire.

### Additional Data on 9" Cathode-Ray Tube

● THE brightness of the spot on the screen of the 9" tube can be controlled by a modulating voltage applied to grid No. 1. The overall length of the 9" tube is 21" and its base is of medium 6-pin type.

With regard to the frequency range of the sweep circuits, for the vertical sweep the range is approximately up to the 20th harmonic of 60 cycles or 1200 cycles. For the horizontal sweep circuit, the upper limit is the 10th harmonic of the fundamental of 13,000 cycles, or about 100,000 to 130,000 cycles.

One of the accompanying diagrams shows the voltage supply circuit for the type 1800-9-inch tube.

At the start of the oscillation, the upper end of the primary may rise to a very large positive voltage, as high as 3000 volts. This voltage is impressed on the plates of the 42's as well as on the cathode of the 1-v. Because this voltage is much higher than the maximum value for which the 42 and

1-v are rated, some tubes may have a short life in this circuit. It is suggested that the heater of the 1-v be operated at 4 volts, instead of at the rated value of 6.3 volts, in order to reduce the temperature of the insulation in the tube and thus enable the tube to withstand better the high inverse voltage.

It can be seen that the 100-ohm non-inductive resistors are connected in series with the grids of the 42's; the purpose of these resistors is to suppress parasitic oscillations. The leads from the resistors to the grids should be short.

For the 9" tube the horizontal-centering control requires a current in the order of 400 milliamperes.

The values of C<sub>6</sub> and R<sub>11</sub> are somewhat critical and depend on the design of the transformer T<sub>2</sub>. For some transformer designs, the optimum values may be different from those shown in the diagram.

The circuit as drawn in Fig. 3 is designed for operation of the RCA-1800 at an anode No. 2 voltage of 6000 or 4500 volts. For an anode No. 2, potential of 3000 volts, two 42's are not necessary in the output stage; a single 42 can supply sufficient deflecting current.

#### Maximum Ratings and Typical Operating Conditions 9" Tube

High-Voltage Electrode (Anode No. 2) Voltage	7000 max.	Volts
Focusing Electrode (Anode No. 1) Voltage	2000 max.	Volts
Accelerating Electrode (Grid No. 2) Voltage	250 max.	Volts
Control Electrode (Grid No. 1) Voltage	Never positive	
Grid No. 1 Voltage for Current Cut-Off*	—75 approx.	Volts
Fluorescent-Screen Input Power Per Sq. Cm.	10 max.	Milliwatts
Typical Operation:		
Heater Voltage	2.5 2.5	2.5 Volts
Anode No. 2 Voltage	3000 4500 6000	Volts
Anode No. 1 Voltage (approx.)	625 925 1250	Volts
Grid No. 2 Voltage	200 250 250	Volts
Grid No. 1 Voltage	Adjusted to give suitable luminous spot	
Grid No. 1 Signal-Swing Voltage (Approx.)**	20 25 25	Volts
*With approximately 250 volts on grid No. 2.		
**Peak-to-peak value for optimum contrast.		

(This article has been prepared from data supplied by courtesy of RCA Manufacturing Co.)



**HAM SPECIAL!**  
Western Electric  
211E TUBE

High Power Amp. or Osc. (on 40 to 160 meter bands). 65 watt continuous plate dissipation; 100 watts intermittent. Four pin 50 watt base. Replaces 211A and 211D. Limited quantity. All brand new in factory sealed cartons.

ONLY \$4.50

**SEND YOUR ORDER IN TODAY**  
Complete Sections on 'ham' equipment, parts, tools, etc. Lists 70 brilliant 1938 Lafayette Receivers. Don't delay! Clip Coupon for FREE catalog.

**WHOLESALE RADIO SERVICE CO. INC.**  
NEW YORK, N.Y. • CHICAGO, ILL. • ATLANTA, GA.  
BOSTON, MASS. • BIRMINGHAM, ALA. • DENVER, CO. • HOUSTON, TEX.  
LOS ANGELES, CALIF. • PHOENIX, ARIZ. • PORTLAND, ORE.  
SAN FRANCISCO, CALIF. • ST. LOUIS, MO. • WASHINGTON, D.C.

**WHOLESALE RADIO SERVICE CO., Inc.**  
901 W. JACKSON BLVD., CHICAGO, ILL.  
Rush FREE 1938 Catalog No. 69-4C8.

Name \_\_\_\_\_  
Street \_\_\_\_\_  
City \_\_\_\_\_ State \_\_\_\_\_

FAST DELIVERY ON PENNY POST CARD

## ● DON'T BUY A RECEIVER

Until you see our New Catalog!

We sell all makes—all models—from the smallest Beginner's set to the largest communication and home receiver—at Substantial Savings!

Write today! Tell us the receiver you want to buy and we will save you money! Delivery anywhere in the World.

**ACE RADIO**  
227 GREENWICH STREET  
NEW YORK CITY



**ASTATIC**

Licensed Under Brush Development Co. Patents

### PALM CONTROL

Astatic Grip-to-Talk Model CD-104 features palm-control switch, cutting microphone in or out, at will. A desk or hand instrument for many types of communicating systems. Chrome and telephone black finish. Complete with cable. Full year guarantee. LIST PRICE \$27.50.

**ASTATIC MICROPHONE LABORATORY, INC.**

Dept. J-5, Youngstown, O.

## The Listener Asks

(Continued from page 612)

considerable difficulty in holding the short-wave stations. It seems that there is a rapid fading on nearly all of the stations I have heard. I would like to know if there is any method of overcoming this condition.

A. This is one of the many obstacles which make short waves interesting. The fading condition you speak of is undoubtedly not due to the receiver which you are using, as most of the short-wave stations picked up in this country fade at some time or other. This can be overcome somewhat by the use of a receiver having automatic volume control. However, in most cases when a station fades, serious distortion takes place, and even though a signal is brought back to normal volume, due to the action of the receiver, it is so distorted that it may just as well have faded out. We know of no method by which this fading condition can be absolutely overcome, and it will probably be quite a time before engineers have worked out a successful method for the home receiver.

## C Q.

A week after a Scotchman bought a midget set he was asked by the salesman how it was working. The Scotchman answered:

"She's all right to listen to, but the bulbs in the back are nie good to read by at night!"—Maurice Wynne

XE4BV, at his office one afternoon, probably wouldn't have been in such a peaceful frame of mind, had he known that his two children back home had found the switch to his 75-meter phone and thrown the rig on the air. For the next hour or so, the all-suffering ether was bombarded with a succession of long and sundry CQ's shouted in lusty juvenile voices "just like Daddy." What "Daddy" said and did when he got back home, however, makes another, much sadder story.—W. K. Angus, VE4VJ

The real inventor of radio was Noah. He built an arc long before Hertz, Marconi, and the others were even thought about. But he wasn't the first "Ham" because of his arc. He decided to let his son have the honor, and named him Ham!—Charles Kohler

Please mention SHORT WAVE & TELEVISION when writing advertisers



# BRINGS YOU ANY ONE OF THESE 4 FAMOUS RADIO BOOKS

**RADIO FANS!** Help yourselves to a radio education for the price of 10c per book. These books give you a good foundation towards the study of radio. You'll be amazed at the wealth of information contained in them. They are especially written for beginners but are useful review and reference books for all.

Each book contains 32 pages, profusely illustrated with clear, self-explanatory diagrams. They contain over 15,000 words of clear legible type. They are an education in themselves and lay the groundwork for a complete study of radio and electricity.

## HOW TO BUILD FOUR DOERLE SHORT WAVE SETS

Due to a special arrangement with the publishers of **SHORT WAVE CRAFT**, we present in this book complete details for building the Doerle sets, also an excellent power pack if you plan to electrify any of the sets. Contains **EVERYTHING** that has ever been printed on these famous receivers. These are the famous sets that appeared in **SHORT WAVE CRAFT**: "A 2-Tube Receiver that Reaches the 12,500 Mile Mark," by Walter C. Doerle, "A 3-Tube Signal Gripper," by Walter C. Doerle, "The Doerle

## HOW TO MAKE THE MOST POPULAR ALL-WAVE 1 AND 2-TUBE RECEIVERS

This book contains a number of excellent 1 and 2-tube sets, some of which have appeared in past issues of **RADIO-CRAFT**. These sets are not toys, but have been carefully engineered. They are not experiments. To mention only a few of the sets the following will give you an idea. The **Megadyne**—1-Tube Pentode Loudspeaker Set, by Hugo Gernsback—Electrifying The Megadyne—How to Make a 1-Tube Loudspeaker set, by W. P. Chesney—How to Make a Simple 1-Tube All-Wave Electric Set, by F. W. Harris—How To Build A Four-in-Two All-Wave Electric Set, by J. A. Bernsley, and others. Each set is fully described in simple language so that anyone can build with limited means and with practically no experience a worth-while all-wave radio set. Has 30 illustrations. **10c postpaid**

## ALTERNATING CURRENT FOR BEGINNERS

This book gives the beginner a foothold in electricity and radio. Electric circuits are explained. This includes Ohm's Law, alternating current, sine waves, volts, amperes, watts, condensers, transformers, motors and generators. A.C. instruments, house-wiring systems, electrical appliances and electric lamps. Here are some of the practical experiments which you can perform. Simple tests for differentiating between A.C. and D.C.; how to light a lamp by induction; making a simple electric motor; demagnetizing a watch; testing motor armatures; charging storage batteries from A.C. outlet; testing condensers with A.C.; making A.C. electromagnets; frying eggs on a cake of ice; making simple A.C. motors and many others. Has 42 illustrations. **10c postpaid**

## ALL ABOUT AERIALS

In simple, understandable language this book explains the theory underlying the various types of aerials; the inverted "L," the Doublet, etc. It explains how noise-free reception can be obtained, how low-impedance transmission lines work; why transposed lead-ins are used. It gives in detail the construction of aerials suitable for long-wave broadcast receivers, for

J. DAUGHARTY,  
3038 W. VanBuren St.,  
Chicago, Illinois.

## He Likes Our New Type

*Editor,*  
*Uncontrolled Oscillations* in the January issue inspired this missive. I want to compliment you on the January issue. It has the most distinctive cover I've ever seen. One correction though, why not show a set in the insert, not a fever machine. I like the informality of the magazine gained through the new arrangement and the style of printing.

Now for the other half of this letter: The three bad points are; (1) the absence of simple sets—not everybody wants to or can afford to build a five tube set every month just for experimental purposes, so why not give three or four one- or two-tube sets every month using about the same parts. (2) Ads through the whole magazine. If anybody wants to read the ads (and who doesn't) they would look at them wherever they are, but nobody likes to thumb through half a dozen pages of ads to find an article on something that should be with its brothers up front. (3) Why put the word *Television* on the cover when all you have is some pictures on it. I don't think there's anyone who isn't interested in the subject or who knows so much about it that they want you to discontinue printing it. Give us a few articles on the principles of it, so we can understand what it's all about. Let's have some interesting justification of the word.

Here's my opinion on SWL cards. I should think (I'm not an Amateur) that anybody would be interested in how his signal is getting out under various conditions. What's the difference who hears your "sig," if he's willing to report it to you? To settle the question, why not have the *Short Wave League* print some QSL cards that have blanks for a comprehensive report by the SWL. Then when one of these cards is received, the Ham will have some information that's worth while. A chart on the R scale wouldn't be amiss either. For example R1 is when the signal can just barely be heard over the phones or speaker, whichever the set drives,—R5 would be the average sig while R9 would necessitate turning down the volume. This wasn't written on asbestos paper as N2DDV suggests, although I'll admit the typewriter was a little worn.

I'm going to sign off out of consideration to the editor and readers to leave some room for those articles on *television* and *simple sets*. I'll be glad to hear from anybody on anything.

WARREN PREESHL,  
Box 113,  
New Richmond, Wisconsin.

(Okay, Warren, we'll try to follow through and we're starting the "television" articles right now.—Editor.)

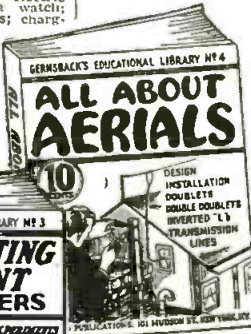
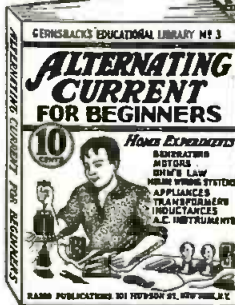
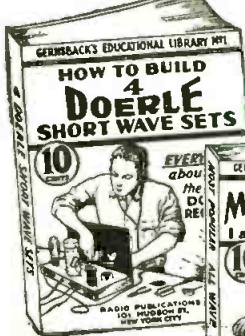

"2-Tuber" Adapted to A.C. Operation," "The Doerle 3-Tube Signal Gripper" Electrified," and "The Doerle Goes Band Spread." Has 30 illustrations. **10c postpaid**

A.C. and Battery Loudspeaker Sets. Has 30 illustrations. **10c postpaid**

How to Build 4 Doerle Short Wave Sets. Has 30 illustrations. **10c postpaid**

How to Make the Most Popular All-Wave 1 and 2 Tube Receivers. Has 30 illustrations. **10c postpaid**

**RADIO PUBLICATIONS** SWT-3-38  
101 Hudson Street, New York, N. Y.

Please send immediately **POSTPAID** the books checked:

No. 1—How to Build 4 Doerle Short Wave Sets...10c

No. 2—How to Make the Most Popular All-Wave 1 and 2-Tube Receivers...10c

No. 3—Alternating Current for Beginners...10c

No. 4—All About Aerials...10c

I am enclosing..... the price of each book is 10c

Send me **FREE** circular listing 48 new 10c publications

Name .....

Address .....

City.....State.....

(U. S. Coin or U. S. Stamps acceptable.) Books are sent postpaid.

Remember that each book has 32 pages and contains over 15,000 words. Each book has from 30 to 66 fine illustrations. **POSITIVELY THE GREATEST 10c VALUE IN RADIO BOOKS EVER OFFERED TO THE PUBLIC.**

If you do not think that these books are worth the money asked for them, return them within 24 hours and your money will be instantly refunded.

Send for our **FREE** circular listing 48 new 10c Publications

**RADIO PUBLICATIONS**  
101 Hudson St., New York, N. Y.

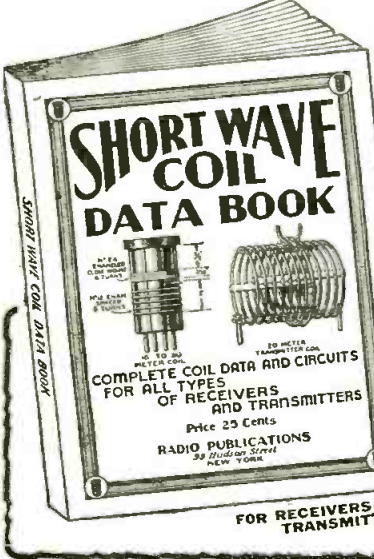

# The 1 and ONLY

## SHORT WAVE COIL DATA BOOK

Every experimenter knows that the difference between a good and a poor radio set is usually found in the construction of short-wave coils. Coil winding information is vitally important, and in the new coil book all "dope" appears. There's illustrations which give instructions on how to wind coils, dimensions, sizes of wire, curves and how to plot them. Every experimenter needs this book—it also contains complete data on all types of receiving coils, together with many suitable circuits using these coils. Also complete data on various types of transmitting coils with many transmitting circuits such as exciters and amplifiers using the various coils described.

### Contents Briefly Outlined

- S-W Tuning Inductance Charts • Coil Data for T. R. F. Receivers • One Tube Oscillators • Two Tube Bandspreeder
- The Mono-Coil • 2-Tube Old Reliable • 2-Tube Globe Trotter • 2 Winding Coils—10-500 Meters • Doerle 3-Tube "Signal Gripper," Electrified • 3-Tube Bandspreeder for the Ham • General Coverage Coils on Ribbed Forms • Coil Data for Superhet or S-W Converter • Ultra S-W Coils • Switch Coils for S-W Superhets • Experimental Coils • S-W Antenna Tuner • Most Popular S-W Tuning Circuits • Self-Supporting Transmitting Circuits Employing Coils Described • All Band Antenna Tuner for Transmitters • Plug-In Coils for Exciters • Frequency-Wavelength Conversion Chart.

**PRICE 25c PREPAID**

For a copy of this handy book, send 25c in U.S. Coin or stamps to

**RADIO PUBLICATIONS**  
97 HUDSON STREET NEW YORK, N. Y.

### His Blood Boiled!

Editor,

I have been reading your magazine for some two years and this is the first time it made my blood boil. I am, of course referring to the nice bit of slander one honorable radio amateur, Charles Fiege, Jr., dished out in your January issue, and I am now taking the stand to defend my fraternity brothers.

In the first place if we want to spend the money and take the time to solicit QSL's from all over the world, that's our business, and I think the best thing for you to do is just don't bother yourself with answering the SWL's, and leave it to the more *unselfish amateurs* who appreciate the sincerity of the whole thing.

As for the R9 reports, that gives me a laugh! You probably have the SWL pictured as a young kid with a two or three-tube receiver, and sweating the stations out of a pair of earphones. Well let me tell you there are many SWL's who have just as good receivers as the hams. In fact, I have a new 1938 Hallicrafter Super-Sky-rider myself, and when I tune over the American phone band the S-meter very seldom drops below 9, only on the most adverse weather conditions, no matter if the stations are W7's or W2's. So don't think we are trying to flatter you when we give an R8 report.

Furthermore we are not interested in what becomes of our SWL cards, whether they are tacked on the wall, put in the far corner of some drawer, or thrown in the waste-paper basket. It is immaterial to us, because we know the amateur's pride is in the station cards he "works," and not so much in the cards stating that he was "heard."

And last but not least, the call formation W2SWL etc., is *not* a violation of the Radio Act of 1934, because there are no amateurs assigned to these calls, due to the fact that the SWL's use them; therefore, if there are no such calls, which every amateur knows, one would be rather foolish to try and bootleg these calls. Hoping that I have pleaded my case to an acquittal, I remain

NORMAN W. HASTINGS,  
P. O. Box 325,  
Middletown, N.Y.

### What Does a Martian Look Like?

Editor,

In your article by Professor Menzel on signalling Mars and its possibilities, you've given some guys a raw deal. I mean in that graph business concerning the message overheard on 5 meters by the professor. It's a good thing he said, "if it came from Mars" instead of something more definite. When I had the graph finished, what did I have? Of all things, *Mickey Mouse!* Pants, big ears and all! I suppose that came from Mars!

Enclosed is the drawing taken from the graph I drew up. It's a good job. I've got a sense of humor as it were. Some fellows aren't going to like that, after a feverish half hour or so of desperate calculations. So that's a Martian is it? Well, well! It might be possible you know, but it bears too much resemblance to our beloved Mickey to stand the gaff. If it had been any other kind of a mouse, maybe it could be a Martian. For all we know, the "high intelli-

gence" on Mars may be beetles or ants or worms.

So far the only definition of a creature from outer space seems to be some form of human being with a bulging forehead (no offense to Mr. Gernsback) or other forms of seeming intelligence. Why so, I ask?

Just because we need air, water and other necessities to live on earth does not mean that a Martian has to have the same things in order to live. Nor does it mean that he has to be composed of flesh and blood like us *Earthians*.

A Martian could be anything, because we have never seen one (consciously) and he, she or it could be of crystalline or even organismic composition.

Suppose a Martian was in some form well-known to us, what then? When you swat a fly or step on a spider or see some native from a far-off land, how do you know that he isn't a Martian? These meteors we hear about crashing into the earth in some obscure part of the world—how do we know they aren't "space-ships" from other space worlds? No, we have no definite proof that they are, but on the other hand, we have no definite proof that they are not!

However, enough of this rambling, but I couldn't help having a say in "Martian affairs."

All the above may seem a little incoherent, but I am writing this at 3 a.m. and listening to some guy gargling his throat on a little home-built "3-lunger" using a 27, 26 and 71A, transformer audio'd. I can't use earphones on her, she's too loud!

Again, more power to S.W. & T.!

JOHN R. KINCH,  
Copper Cliff,  
Ontario, Canada.

(Swell, John, and we hope many more readers will get the "old bean" working and let us have their slant on what they think of communicating with Mars, if inhabited. We trust that our readers will write us on other subjects—discuss good or bad features in articles published in this magazine. Perhaps you have a different theory, a new way of connecting a detector, etc. Tell us about your ideas in your own way. Keep your letters as brief as possible.—Editor.)

### We Beat the Dutch!

Editor,

I am a regular reader of "S.W.&T." One issue brings me more news than four or five Dutch ones.

I have built a receiver which was described in "S.W.&T." and I must say it is marvelous; it didn't cost half the price of one built with Dutch components and tubes.

The conditions for S-W fans and amateurs in the States are much better than here, because the components (especially the tubes) are cheaper; a whole American receiver does not cost the price of the tubes here in Holland. Another important thing is that in the States the fan or amateur can choose between various makes and here we can only choose between three or four.

My first issue of "S.W.&T." established for me the beginning of a new period in DXing, and from every succeeding issue I learn something new.

When one or another S-W fan or amateur wants to know something about radio or television here in Holland, let him write me a letter and I promise that I shall answer the letter to the best of my ability. Wishing *Short Wave & Television* every success, I close this letter and greet you all.

HARRY PISART,  
11 Noorderstraat,  
Amsterdam, Holland.

## RCA OSCILLOGRAPH PRICES REDUCED!

Overwhelming sales of these instruments greatly increase production—bring prices down! Buy now—and save!

WAS \$84.50  
NOW \$63<sup>95</sup>

Stock No. 9545 RCA 3-inch Cathode Ray Oscillograph

Thousands have been sold during the three short years since this splendid instrument was introduced. Its sensitivity is 0.7 volts (R.M.S.) per inch... linear saw-tooth sweep oscillator, 10 to 18,000 cycles... 2 wide range amplifiers, 10 cycles to 90 kilocycles. Gain 40... Complete with Tubes.



WAS \$47.50  
NOW \$39<sup>95</sup>

Stock No. 151 RCA 1-inch Cathode Ray Oscillograph



This Oscillograph will give you "big time" performance. Its sensitivity is 1.75 volts (R. M. S.) per inch... amplifier range—30-10,000 cycles. Gain 50... Linear timing axis (horizontal sweep)—30-10,000 cycles... All controls on front panel... Gray wrinkle lacquer finish with nickel trimming. Complete with Tubes.

Over 300 million RCA Tubes have been bought by radio users... In tubes, as in test equipment, it pays to go RCA ALL THE WAY!

Listen to the Magic Key of RCA every Sunday 2 to 3 P. M., E. S. T. on NBC Blue Network.

### Parts FOR PROFIT

RCA Manufacturing Co., Inc., Camden, N. J.  
A Service of Radio Corporation of America

## AT LAST!

Our New catalog is completed.

If you are looking for VALUES, this is the book in which to find them.

Don't fail to send for  
**YOUR COPY**

**TRY-MO RADIO CO., INC.**

85 Cortlandt St., Dept. 3-8, New York City

### KEEP your home ORDERLY

Don't leave magazines scattered all over the house. Gold Shield Holder will keep them CLEAN.

12 3/4" x 9 1/2"

3/4" x 9 1/8"

Made of heavy cardboard, covered with Genuine DuPont fabricoid—holds 24 magazines.

Holder, 50c each, 10 for \$2.50 prepaid. Nickel silver Autogram initial, illustrated above, 10c each. Two or three initials look swell on the bottom right hand corner of the holder.

### GOLD SHIELD PRODUCTS

Dept. S-3 98 Morningside Ave., New York City

### 110 VOLTS A. C.

Fan belt generator for sound trucks. Produces constant voltage at various engine speeds. Cannot be burned out. Also good for operating flood lights, car heating, electric drills, neon signs. Sizes: 250 to 1000 watts. Prices from \$25.00 net.

**LEJAY MFG. COMPANY**  
117 LeJay Bldg., Minn., Minn.

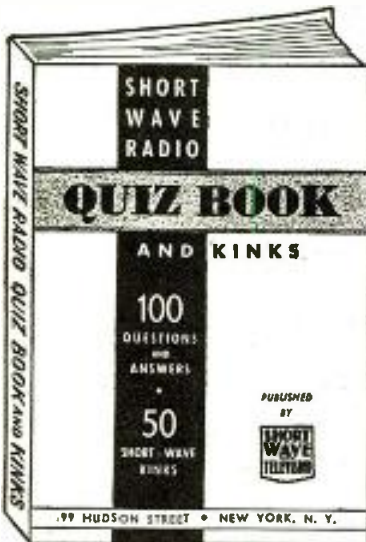

**WE HAVE NEVER MADE SUCH AN OUTSTANDING OFFER TO OUR READERS!**

HERE is a brand new book—with an unusually interesting content. The text—prepared by the Editorial Staff of SHORT WAVE AND TELEVISION, contains a variety of material which only experts could select and incorporate in such an excellent volume. "SHORT WAVE RADIO QUIZ BOOK AND KINKS" cannot be bought—it is sent to you absolutely FREE with your subscription to SHORT WAVE AND TELEVISION at the Special Rate of Seven Months for One Dollar. (Old subscribers may get this book by extending their subscription.) The book contains 64 pages with a heavy flexible colored cover. It measures 5½x8½ inches, and includes hundreds of photographs and diagrams. The contents are outlined below.

Questions and Answers Covering S-W Transmitters.  
 Questions and Answers Covering S-W Receivers.  
 Ultra-Short-Wave Transmitters and Receivers.  
 S-W "Kinks"—Short-cuts and Practical Wrinkles, Coil Winding Data.  
 How to Add an Audio Amplifier to a Small

S-W Receiver.  
 How to Connect an R.F. Stage Ahead of Your Present Receiver.  
 Dozens of Novel New Hook-Ups for the S-W Experimenter.  
 Clear diagrams showing how to connect the latest type tubes in place of your old tubes, so as to obtain greater DX.

**HOW TO "HOOK UP"—**

S-W Converters      Power supplies      Beat Oscillators      Pre-selectors  
 Noise Silencers      Modulators      Antennas      5-meter receivers

**SHORT WAVE AND TELEVISION • 99 Hudson Street • NEW YORK, N. Y.**

SHORT WAVE AND TELEVISION, 99 Hudson Street, New York, N. Y.

Gentlemen: Enclosed you will find my remittance of \$..... for which enter my subscription to SHORT WAVE AND TELEVISION for

- 7 months—\$1.00—choice of any one of three (3) books. (Canadian and foreign—\$1.30)
- 14 months—\$2.00—choice of any two (2) of the three (3) books. (Canadian and foreign—\$2.60)
- 21 months—\$3.00—all three books (Canadian and foreign—\$3.90)

If you are a subscriber now, we will extend your present subscription.

- Books are to be mailed POSTPAID.
- New subscriber
  - Old subscriber

Name ..... Address .....

City ..... State .....

Send your remittance by check or money order. If you send cash or unused U.S. postage stamps, please be sure to register your letter for your own protection.

Dept. SWT-333

**2 Other FREE Books ABC OF TELEVISION**



Contains latest material on Television developments. It covers theory of scanning; simple television receiver; how the eye sees; the photo-electric cell; neon lamps; need for broad channel width in transmission of high-fidelity television signals; cathode ray tube and television receivers; Farnsworth system of television transmission, and other important features.

**SHORT WAVE GUIDE**

Covers hundreds of Short-Wave questions and answers; illustrates popular Short-Wave kinks; gives instructions for building a simple Short-Wave receiver; instruction on the best type of antenna to use; diagram and construction details for building a simple "ham" transmitter; practical hints on Short-Wave tuning.



**Television Terms Explained**

(Continued from page 635)

**FUNDAMENTAL FREQUENCY** — The lowest component frequency of a periodic wave.

**G**

**GAS-FILLED TRIODE**—A triode tube having a filament, grid and anode; but instead of the glass bulb enclosing these electrodes being exhausted to as near a perfect vacuum as possible, a small amount of an inert gas (neon, argon, etc.) is purposely inserted. Various trade names are used, such as, "Thyatron, Grid-glow Tube," etc.

**H**

**HEAVISIDE LAYER**—An ionic layer which shifts in height above the earth over different periods of the day and night, as well as with the seasons. Also called the "Ionosphere."

**HORIZONTAL DEFLECTION PLATES**—That pair of electro-static deflection plates in a cathode ray tube which produce the horizontal deflection of the cathode ray beam.

**HORIZONTAL BLANKING IMPULSE**—An electrical impulse transmitted at the end of each scanning line to erase the luminous spot from the cathode ray receiver tube screen during the retrace period of the spot to the start of the next line. Also called "Line Frequency Blanking Impulse."

**HORIZONTAL SCANNING FRE-**

**QUENCY**—This is the frequency of the linear sawtooth wave used for scanning in the horizontal direction. It is equal to the number of lines scanned per second. This is also called, and is defined by the RMA, "Line Frequency."

**HORIZONTAL SYNCHRONIZING IMPULSE** — A special electrical pulse transmitted at the end of each line to keep the horizontal scan of the television receiver in step with that of the television transmitter. Also called "Line Frequency Synchronizing Impulse."

**I**

**ICONOSCOPE** — A trade-name used by RCA for a particular type of cathode ray tube developed for the purpose of picking up scenes to be televised.

**INTERLACED SCANNING**—A process of scanning whereby a complete picture is created by projecting two or more sets of lines; each set, commonly called "field," containing a fraction of the total number of lines, and spread uniformly over the picture area.

**ION**—In the usual radio application it is an atom which is minus one or more electrons, thus creating a positively charged atom.

**IONIZATION**—The process of creating an Ion.

**K**

**KEYSTONE EFFECT** — A distorted field or background noticed in a reproduced television image wherein opposite edges of an object having parallel sides are not parallel.

**KINESCOPE**—A patented name of the RCA Company covering their cathode ray picture reproduction tubes.

**L**

**LINEARITY**—In a graphical representation of the relationship between two factors plotted one against the other where the resultant "curve" is a straight line, this is a linear function or relationship. The more nearly this relationship does approach a straight line the more nearly linear it is said to be.

**LINE FREQUENCY**—(As defined by the Radio Manufacturer's Association) The line frequency is the frequency of the sawtooth wave used for scanning in the horizontal direction, and is numerically equal to the number of lines scanned per second.

Copyrighted by First National Television, Inc.—1937. Prepared by Everett L. Dillard, Tech. Supervisor Resident Training, First National Television, Inc., Kansas City, Missouri.

(To be continued)

Please mention SHORT WAVE & TELEVISION when writing advertisers

# DATA PRINT SERVICE

New low price—  
Any 3 Prints.....\$1.00

## TESLA COIL DATA:

Data print—drawings and data for building 36-inch spark Tesla, 50c  
Exciter—1 K.W. 20,000 Vt. Transf. 50c  
3" Spk. Tesla Coil. Works on Ford Coil 50c  
3" Spk. Oudin Coil. Works on 110 A.C. 50c  
20 "Tricks" with Testas & Oudins 50c  
8" Spk. Tesla Coil. 50c  
Exciter—1/4 K.W. 15,000 Volt Transf. 50c  
Violetta—1" Spk. Oudin, Vibrator type 50c  
How to Operate Oudins from V. T. Osc. 50c



## S-W DIATHERMY (Artificial Fever)

Data print giving Constructional data for Small, Medium and Large size API. (All 3)...50c



## RECORD PROGRAMS on Steel Wire!

Telegraphone Data, for Voice or Code.....50c

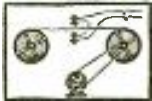

## Induction PIPE & ORE LOCATOR

Construction Data.....50c



## 20 ELECTRIC LODGE & PARTY TRICKS. Fun Galore!

"How to Do 'Em" Data 50c



## RADIO CONTROL for MODEL BOATS, etc.

Circuit data .....50c

More **DATA PRINTS** You Need!



50c each.....3 for \$1.00

Electric Pipe Thawer any clock  
100 Mechanical Movements "Retwinding" Armatures  
Water Turbines Induction Balance  
Water Wheels Telautograph  
Motor Circuit (20) Elmhoven String Galva-  
Telephone Hook-ups (20) noter  
Polarized Relay, Ultra- Magnets and Solenoids—  
sensitive Get our list  
Ring 4 bells on 2 wires Wheatstone Bridge  
20 Simple Bell Hook-ups Induction Coils—1 to 12  
Electric Chime Ringer fits inch Spk data  
Welding Trf. 2 K.W. 110 V. Prim. 18 V. Sec.....50c  
4" metal SLIDE RULE \$2.00; 8" (20" Scale) \$5.00

## The DATA PRINT Co.

Lock Box 322 RAMSEY, N. J.



## Universal Mounting Condensers

● MECHANICAL difficulties in mounting high voltage filter capacitors are entirely eliminated with the universal mounting brackets introduced by Cornell-Dubilier. As the illustration shows, mounting in all positions is easily accomplished. Impregnated and filled with dykanol in hermetically sealed containers, the condensers can be mounted in any position without altering or affecting the electrical characteristics.

(No. 692)

This article has been prepared from data supplied by courtesy of Cornell-Dubilier Electric Corp.

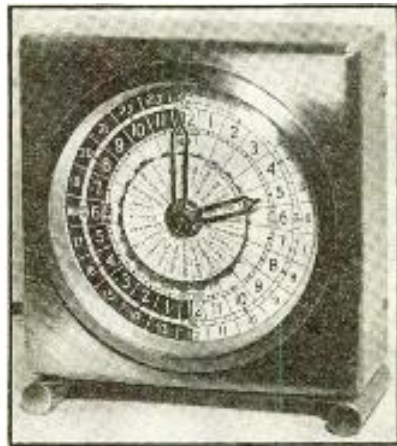

## New World-Time Clock

● BY an ingenious dial construction the Sky-Pilot world-time clock enables the user to determine the time in any part of the world without calculations. As shown in the photograph the dial has a double row of figures arranged in circular form.

In addition, there is a smaller central dial which rotates with the hour hand of the clock. This rotating dial has the names of the principal countries and cities in the various time-zones of the world printed on its face. This movable dial is set at the time of installation for the time-zone in which the clock is to be used. (No. 691)

This article has been prepared from data supplied by courtesy of the Sky-Pilot Organization.

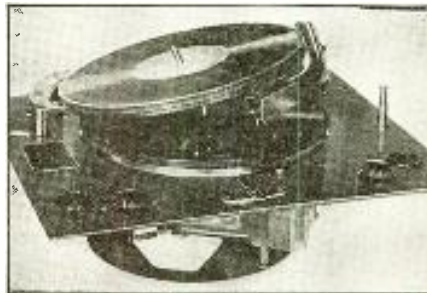

## New Record Changer

● A NEW Record Changer introduced. This Record Changer will play either eight 10" or eight 12" records. There are many unusual features incorporated in this record changer. It is available in any current, and also with crystal pick-up.

(No. 690)

This article has been prepared from data supplied by courtesy of the Garrard Sales Corp.

# NEW TRIPLET ILLUMINATED THERMO-AMMETERS

Model 446 with Front Illumination. New four-inch square modernistic instrument featuring extra long scale. Available also in ammeters, milliammeters, microammeters, voltmeters, millivoltmeters, etc., A.C. and D.C.

To ANTENNA

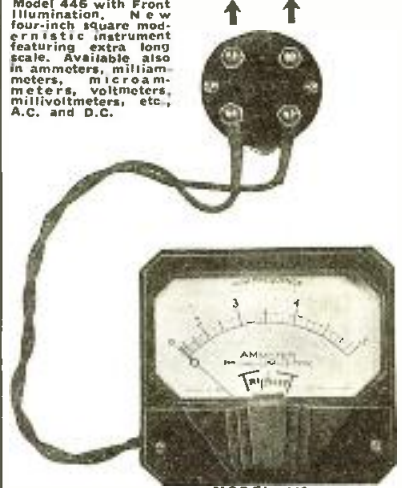

MODEL 446

## PRICES GREATLY REDUCED

Write for Catalog.

The Triplett Electrical Instrument Co.  
283 Harmon Dr., Bluffton, Ohio

Please send me more information on Model 446; I am also interested in.....

Name .....

Address .....

City ..... State .....

# SAVE MONEY!

Buy now at lower prices!

Big Clearance Sale of Surplus Radio Parts and Tubes. All parts and tubes brand new. Send for FREE BARGAIN BULLETIN

SUPREME RADIO SUPPLY CO.  
710-712 Broadway Schenectady, N. Y.

## EXPERT RADIO SERVICE COURSE

Speed tough service jobs. Make more profit. The O-B Visual Service Course gives you "know how." Designed for service men by famous Midland Television School and C-B engineers. For details, see your O-B jobber or write us. Make your time pay more. Don't delay. Write TODAY.

The CLOUGH-BREngle CO.  
2813-E W. 19th St. Chicago, Ill.

SHIPPING Size 2 1/2 x 4

# LABELS \$1.50 per 1000

Printed in RED & BLUE with your name & address. Regular \$3.50 value. SAMPLES.

SAMNICK 305 E. 45th St., New York City  
MURRAY HILL 4-0995

# RADIOS.. SAVE UP TO 50%

DEAL DIRECT...FACTORY PRICES! Many models to select from: A.C./D.C./All-Wave; armchair models; automatic tuning; car radios; Farmets that operate like city radios! Send postcard for NEW Bargain Catalog FREE. 30-DAY TRIAL plan and agent-user proposition! GOLDENTONE RADIO CO. DEPT. C3, DEARBORN, MICHIGAN

"Have you bought your copy of the RADIO AMATEUR COURSE yet? See the inside front cover for details."

# NEVER BEFORE

300 TESTED MONEY MAKERS

MAIL ORDER PLANS

BUSINESS SECRETS

SUCCESS SCHEMES

10¢

Do not fail to send for this important book—the New 1938 Edition has just been published. It's sent post-paid. Remember, all of these plans are genuine, NOT JUST IDEAS, but every plan has been tried out successfully. You can send either coin or U. S. postage stamps.

NATIONAL PLANS INSTITUTE  
246 Fifth Avenue New York City

has the small sum of 10c brought you so much as we offer in our 1938 edition of pure book, 300 TESTED MONEY MAKERS.

In this book you will find all the real money makers which have and still are making money for others.—men who have started on the proverbial shoe-string and often with less than \$10 capital. In this book you will find dozens of successful mail-order plans, many confidential business secrets, successful formulas and many profitable schemes that are being used by small business traders who are making a good but honest living either in their full time or spare time.

WE ONLY ASK YOU TO DEPOSIT THE SMALL SUM OF TEN CENTS WITH US. IF THREE DAYS AFTER RECEIPT OF THE BOOK YOU DO NOT THINK IT WORTH TEN TIMES THE AMOUNT, WE WILL CHEERFULLY REFUND YOUR MONEY.

# CLASSIFIED 15¢ A WORD

Under this heading only advertisements of a commercial nature are accepted. Remittance of 15¢ per word should accompany all orders. Copy should reach us not later than the 5th of the month for the second following month's issue.

### AGENTS WANTED

500% PROFIT SELLING GOLD Leaf Letters for Store Windows. Free Samples. Metallic Co., 446 North Clark, Chicago.

### CORRESPONDENCE COURSES

500,000 USED CORRESPONDENCE Courses and Educational Books. Sold, Rented, Exchanged. All subjects. Satisfaction guaranteed. Cash paid for used courses. Complete details and bargain catalog free. Send name, Nelson Company, 3276 Manhattan Building, Chicago.

### INSTRUCTION

RADIO ENGINEERING. BROADCASTING, aviation and police radio, servicing, marine and Morse telegraphy taught thoroughly. All expenses low. Catalog free. Dodge's Institute, Coit St., Valparaiso, Ind.

### MISCELLANEOUS

WE ORIGINALLY HAD FIVE thousand Stoddart Compasses for which the U.S. Government paid over \$30.00 each. We sold all but a very few. We cannot obtain more to sell at three times our present price. Send in your order before they are all sold at \$4.50 each, postage paid. Gold Shield Products, 88 Morningside Avenue, New York City.

COIL INDUCTANCE CHARTS—complete set for any size coil; accurate; \$2.15 prepaid. Slide Rules—4 inch circular metal type \$2.00; 8" dia., 20" scale, \$5.00 prepaid. DataPrint Co., Box 322, Ramsey, N. J.

### PATENT ATTORNEYS

INVENTORS, ALL PATENT AND trademark cases submitted given personal attention by members of the firm. Form "Evidence of Conception and Instructions" free. Lancaster, Allwine & Hornel, 426 Bowen Building, Washington, D. C.

### QSL-CARDS-SWL

SPECIAL OFFER: 150 NEAT, attractive, 2 color SWL Amateur QSLs, \$1.00, 300—\$1.75. Samples (Stamps). W-8-E-S-N. 1827 Cone, Toledo, Ohio.

SHORT WAVE LISTENER'S Directory. Large Special Winter Issue. 15c. Coins, Stamps. SWL-Directory, Station-B, Box-116, Toledo, Ohio.

QSL, SWL CARDS, NEAT, attractive, reasonably priced, samples free. Miller, Printer, Ambler, Pa.

### SONG POEMS WANTED

WANTED ORIGINAL POEMS, songs for immediate consideration. Send poems to Columbian Music Publishers, Ltd., Dept. K49, Toronto, Can.

# BARTER AND EXCHANGE FREE ADS

### NO ADVERTISEMENT TO EXCEED 35 WORDS, INCLUDING NAME AND ADDRESS

Space in this department is not sold. It is intended solely for the benefit of our readers, who wish to buy, sell or exchange radios, parts, phonographs, cameras, bicycles, sporting goods, books, magazines, etc., without profit. As we receive no money for these announcements, we cannot accept responsibility for any statements made by the readers.

Use these columns freely. Only one advertisement can be accepted from any reader in any issue. All transactions MUST be above board. Remember you are using the U. S. mail in all these transactions and therefore you are bound by the U. S. Postal Laws. Describe anything you offer accurately and without exaggeration. Treat your fellow men the way you wish to be treated. We welcome suggestions that will help to make this department interesting and profitable to both buyer and seller.

Copy should reach us not later than the 5th of the month for the second following month's issue.

COMPLETE BARR TRANSCEIVER, Etc., Excellent W. E. 211-D with socket, 10 volt filament transformer, 0-15 voltmeter; 40 meter Merrill kw. Low "C" coils with capacitor. Sell, trade entire lot or individual items. W5FGU, 318 Boys Dormitory, Weatherford, Oklahoma.

I WILL PAY \$1. per dozen for old license plates. What years have you got? Anthony Shupienus, Newport, N. J.

HAVE COMPLETE 60 WATT Xmitter. Sell for \$40 or best offer. Power supply, RF section antenna matching network, 2 meters, Xtal, plug-in coils, in neat 3 deck cabinet. Write WIKDO, 112 Burr Street, New Haven, Conn.

I HAVE A 2 1/2 H.P. OUTBOARD motor in good condition. Will sell or trade for what have you. Ned Levy, 5310 Pimlico Road, Baltimore, Md.

WILL SWAP AN ANSCO-MEMO Camera and Carrying Case. In condition 6.3 lens for Junior style Instructionograph with tapes or similar code instructor. G. Jacobson, 6706-21 Ave., Brooklyn, N. Y.

WILL TRADE REMINGTON Speedmaster 22 (long rifle) for Phone Xmitter with Modulator and Mike, or late model Super-Skyrider receiver. Rifle used 3 mo. L. V. Lewis, Box 176, Jol, New Mexico.

HAVE COMPLETE ALL-STAR 40 watt C.W. Out. Would prefer cash offer. Will consider trade on good TRF short wave receiver. Kenneth Ryser, 1719 Major St., Salt Lake City, Utah.

WILL SWAP OR EXCHANGE 600 foreign, U.S. all different stamps in brand new album for set of good working earphones. Will answer immediately to any swapper. John W. Plantani, 502 Beech St., North Braddock, Pa.

RIDER MANUALS WANTED. First six volumes. In reply state cash price and condition. Harold F. Lawrence, 59 Anderson St., Ludlow, Vt.

WILL TRADE ONE UNIVEX 8 mm. camera with f 5.6 lens for a used Precision Multimeter Series 830 in good condition. Louis B. Booth, 6 Longworth Ave., Middletown, Conn.

FOR SALE: ONE TWO TUBE battery radio with tubes \$1.00 postpaid. Richard Kershaw, 846 University St., Springfield, Mo.

HAVE U.S. COMMEMORATIVES and many high grade foreign stamps. Want art photos, magazines, books and 8 mm. movie films. W. M. McDonald, 271 Pearl Street, Cambridge, Mass.

WANTED: LETTER SIZE FILE, wood or metal, any number of sections. Will pay cash or exchange most anything. Frank R. Sanford, 29 Pleasant Street, Ansonia, Conn.

WILL TRADE 4 TUBE A.C. midget radio for an 8 base or piano accordion. Write Gordon G. Iluehse, 122 W. Clark St., Brookfield, Mo.

AN ELECTRIC TRAIN SET A-1 condition and box of chemicals and apparatus. Will trade for good pre-selector or signal booster and gestic button mike. (sent prepaid). Harry L. Hale, 1756 Wallen Ave., Chicago, Ill.

BRAND NEW 5 METER TRANSCEIVER for sale. 3 tube Class "B" modulated. Has range of 75 miles. Give all information on request. Can give immediate shipment. Richard Noel, Cox School, South Wales, N. Y.

WILL SWAP A SHURE SPHEROID crystal mike, model 74B, for portable typewriter in good condition. Mike practically new. Write giving model, condition, and age of typewriter. R. Boario, P. O. Box 304, Leechburg, Penna.

WANTED, READRITE ANALYZER Model 712A, or Triplett Model 1131A, also Rider Manuals of all volumes. State cash price and condition in reply. Modern Electric, Middle Valley, N. J.

WHAT HAVE YOU FOR 3 ROLLER Smith O-3 D.C. voltmeters. Will furnish instructions for making test meter. To 1500 volts. All accurate within 3%. (3" in size). Mack Higginson, c/o 1938 Park Ave., Indianapolis, Ind.

U.S. MINT STAMPS, SINGLES, plate numbered blocks, panes and sheets, both 19th and 20th century, for exchange for what have you? Also U.S. postcards, unused and used. B. Cony, 5520 Glenwood Ave., Chicago, Ill.

WANTED: MOTORCYCLE, TWO cylinder, sport model. To buy or better exchange for Cuban products. Send complete details. Jose Rodriguez, Porenir No. 6, Havana, Cuba.

SHORT WAVE LISTENERS IN U.S.A. and foreign countries. Would like to swap my SWL card for one of yours. I will QSL 100% by return mail. Elmer Patrick, 6102 Woodlawn Ave., Maywood, California, U.S.A.

WANTED-SW3 OR PB7XA Receiver, preferably with band spread coils. Also speed "bug" key. Will pay cash. Also have Hallcrafters Sky-Buddy for sale or trade. Phil Moore, WJZZ, 32 Stevens Street, Methuen, Mass.

MUST SELL A LANSING 1500 ohms Dynamic Loud speaker. It is in very good shape and reasonable in price. Robert McManamy, 142 South Wilton Drive, Los Angeles, Calif.

WILL SELL OR TRADE: Old issues of miscellaneous Science Fiction Magazines, including the one and only annual. Will exchange for "ham" equipment or 1930-31 issues of Astounding Stories. Paul J. Patrick, W8YIM, Annandale, Minn.

FOR SALE: R.C.A. 955 WITH socket, first \$2.50 money order takes it. Race 4, less speaker and cabinet, needs tuneup on 8.5 v. make an offer. You pay postage. Dickson Witman, Peters Place, Red Bank, New Jersey.

FOR SALE-17 ISSUES OF ALL-Wave Radio, the latest issues. A buy that cannot be passed up. A important radio information. All for \$2.00. Meredith M. Stroh, 172 Queen St., Kitchener, Ont., Canada.

WILL SWAP COMPLETE HIGH Speed Candler Telegraph Course for late model Sky Buddy or late National S.W.3 or other standard short wave receiver. Wallace A. Braswell, W8PVP, P.O. Box 369, Bunkie, Louisiana.

FOR SALE: ONE PRACTICALLY new, All-Star receiver. Coils from 10 meters to 270 meters. Good Beat Oscillator, well constructed, and Utah speaker. Used tubes included. A bargain at \$23. Donald Johnson, Kimball, S. Dak.

FOR SALE-3 TUBE SKY BUDDY superhet. In excellent condition. 5 tubes function as 8 in this receiver. Complete for \$24.75. Must sell at once. Donald Graham, 1900 Shenandoah Dr., Seattle, Wash.

I HAVE STAMP ALBUM, 1,842 stamps including duplicates, Coronations Jubilee, Commemoratives, also 10 copies S.W. card back issues. Satisfaction guaranteed. Want S.W. set A.C.-D.C. 110 V. Steve Fox, 161 East 34 St., N. Y. C.

FOR SALE: 6 TUBE T.R.F. Receiver, covers from 12-555 meters in 6 bands. Plug-in coils, 2.25 airplane dial with micrometer, bandspread. With tubes, coils and speaker. John Zieger, 181 Waldo Pl., Englewood, N. J.

WILL SWAP SCHICK ELECTRIC shaver used less than fifty times for 2 or 3 tube 6.3 volt receiver or small A.C.-D.C. receiver or 60 cycle electric phonograph motor. Tom Cullen, 22 Simpson Ave., Wallingford, Conn.

SHORT WAVE LISTENERS IN the world, let's exchange SWL qsl cards, correspond in English, German and French. QRA Ric Spirakle, 2258 West 24 St., Chicago, Ill., U. S. A.

SELL OR TRADE: SIX TUBE broadcast band superheterodyne battery radio with good set 2 volt tubes, also new Westinghouse Generator 110 volts A.C. 200 watt ballbearings and aluminum housing. Make offer. Carl McCarty, Box 79, Califorma, Pa.

SWAP OR SELL-250 WATT AC generator, 60 cycle Triplett all wave signal generator, battery type. Want phone pickup, motor, amplifier, test equipment. J. L. Orsen, 107 1/2 Miner Ave., Ladysmith, Wis.

WILL SELL OR SWAP ELECTRIC phonograph turntable complete with regulator and switch, 110 volts A.C. for three or four tube short wave receiver. Bayard Bernard, North Main St., Jamestown, Ky.

FOR SALE: CANDLER COURSE; Mackey (1937 DeLuxe Model) and National Oscillator, all used but as good as new; \$20. Anthony Guide, 15 Wolcott Street, Malden, Mass.

(Continued on opposite page)

## Let's Listen In With Joe Miller

(Continued from page 617)

a.m. Both at Nazaki. Also JYS, 9.87 mc., Kemikawa-Cho, phoning KWU, at 9 p.m. JYS is rarely heard. And JIB, 10.54 mc., Taiwan, Formosa, at 10 a.m., very often.

From Harry Homda, W6, JZL, 17.785 mc., Nazaki, will be a regular Overseas Broadcaster, from 4:30-5:30 p.m., after the winter season, so look for JZL. JVN listed as on from 1:45-2:20 a.m., with market quotations and news. JVH, 14.60 mc., heard from 7:30-8 a.m. JVO, 10.37 mc., heard broadcasting to Manchukuo at 2 a.m.

Jim Lanyon, VE5, reports JFZC, 17.64 mc., the "Chichibu Maru," phoning KKP, 16.04 mc., Kahuku, Hawaii, at 11 p.m. Jim says that during December Asiatics were almost impossible to hear, and Jim's on the Pacific Coast!

Ashley Walcott reports XGOX, Nanking, China, definitely off the air!

Also reported by Ashley is a Xmtr at Canton, believed to be XRV, nearly daily 9:45-10:15 a.m., contacting KWW, 10.84 mc., Dixon, Cal. Frequency is 9.495 mc., this proving it is the old XTV Xmtr, but frequently this station emits some sort of spurious wave on 9.545 mc., sometimes changing entirely over to 9.545 mc.!

Ashley reports Saigon, Indo-China, 6.17 mc., heard till 9:30 a.m., morning, but that the 11.70 mc. freq. has died out on the Coast.

PLV, 9.42 mc., Bandoeng, Java, is reported quite often, phoning at 10 a.m., by G. C. Gallagher, W6. A veri of PMC, 18.135 mc., Bandoeng, Java, was just received, proving that veris of commercial 'phones are still occasionally issued by the Javanese Gov't.

Ashley reports a powerful new Javanese broadcaster on 3.49 mc., a not very short wave, sending Malay programs daily, mornings up to 11 a.m., when station fades out. This station is reported as even stronger than YDA on 3.04 mc.

### OTHER DX

TPZ, 12.12 mc., Alger, Algeria, heard with good signal at 2:30 p.m., when TPZ is often heard, although always using side-band secrecy transmission, by which TPZ is easily identified.

ITK, 16.385 mc., Mogadiscio, Italian Somaliland, heard phoning IAC, 17.70 mc., Pisa, Italy, at 9:30 a.m.

### \* \* HAM STARDUST \* \*

Africans are still being heard, though not every day, from 11 p.m., to midnight, and from 2:30-5 p.m.

Some astonishing reception was experienced on 20 meters during December, on weekend afternoons, and South Africans were heard with up to R8 signals as late as 5 p.m., when they usually fade out at the latest, 3:30 p.m.!

Also, on 10 meters, South Africans are still heard, but now from about 1-1:30 p.m., on to 2:30 p.m. 10 meters is a band to be watched, as it still is unpredictable, and one never knows what may be heard, till one tries.

South Africans on 20 heard during Dec. were: ZS6AY, 14400; ZT6AK, 14380; ZU6AF, 14365; ZU5M, 14400; ZS1J, 14080; ZS6AA, 14355; ZU5Z, 14130; ZU5L, 14120; ZS1B, 14090; ZT5P, 14085; ZS1AL, 14055; ZT6AL, 14085; ZS6AJ, 14075, 14140; ZS2N, 14025; ZT1M, 14040; ZS1C, 14035; ZS6T, 14075; ZU6P, 14060; ZS3F, 14090, 14365; ZE1JR, 14090; ZT5S, 14300.

Please mention SHORT WAVE & TELEVISION when writing advertisers



All these were heard in afternoons and evenings, using the new Sky rider.

Other DX heard on 20 meters: CN8MN, 14320; CN8M1, 14140; CN8AF, 14100, all in French Morocco; OQ5AA, 14085, Belgian Congo; HB9J, 14360, Switzerland; VK2HF, 14300, Sydney, and VK4VD, 14390, Queensland, Australia, all heard 3-5 p.m., most unusual for the "Aussies" at this hour!

It was unusual to hear EA9AH, 14,004, Tetuan, Spanish Morocco, the Spanish War Rebel station, broadcasting the popular tune, "Love thy Neighbor"!

Other 20 meter DX is reported, by Ralph Gozen, W2, LA1F, 14260, Norway, 8:45 a.m., by Murray Buitekant, F18AC, 4035, French Indo China, at 7:45 a.m., and Norman Kreibel, FR8VX, 14350, at 3:10 p.m. Ralph Gozen reports VS6AG, 14090, 7:45 a.m., this one in Hong Kong. All FB DX, boys!

Irv. Goodeve, W8, reports: FB8AB, 14350, at 10:27 p.m., and FB8AF, 14000, also around same time, both in Madagascar.

Also VS2AS, Fed. Malay States, on 14330, and VU2CQ, 14130, in early morning. Irv. also reports a QSL from F18AD, FB!

On 40 meter phone, heard here is EA8AK, 7.12 mc., Canary Islands, at 4:40 p.m., EA9AH on 7.1 mc. at 8 p.m., and CT1FU, Portugal, 8 p.m., 7.25 mc.

Ralph Gozen reports EA8AK, EA8AS, 7.24 mc., and EA8AE on 7.01 and 7.15 mc., all in Canary Islands, in evenings. Also EA9BJ, 7.10 mc., Spanish Morocco. Ralph also reports CT1FU, and F8PU, 7.07 mc., France.

Try "40" in early mornings, 4-6:30 a.m., during Feb., as on good days. VKs are occasionally heard.

On "10," there is plenty of good DX to be heard, if one has a good receiver.

ZT6AK, CN8AV, ZS6AJ, ZS6T, ZE1JR, SP1HH, ON4DM, all heard here on 10 meters, though little has been done on 10. Ralph Gozen reports VU2CQ, ON4MD, EI9J, 11KN, ON4DM, ZS6T, SP1DC, all on 10. Harry Honda reports VK3YP, 28.1, ZL3BN, a New Zealander, 28.14, K7PQ, 29.5, and VK2GU, 28.15 mc.

Harry's catches heard from 5-6:45 p.m., Ralph's near 8:30-10 a.m.

Next month we will publish FR8VX's card, this is a rarely heard amateur in Reunion Island, and details of a special program to be broadcast by 8VX to our readers.

P.S.—M. Wasserzug of Johannesburg, South Africa writes that all South African hams will use calls beginning with ZS—after March 1. ZT and ZU prefixes will be reserved for broadcast stations.

We wish to thank all the OM's, YL's, and XYL's who sent us Xmas greetings, and we also wish them a Happy New Year, and assure them of our sincere gratitude at their kind remembrance.

### Here's Your Button

The illustration here shows the beautiful design of the "Official" Short Wave League button, which is available to everyone who becomes a member of the Short Wave League.



The requirements for joining the League are explained in a booklet, copies of which will be mailed upon request. The button measures 3/4 inch in diameter and is inlaid in enamel—3 colors—red, white, and blue.

Please note that you can order your button AT ONCE—SHORT WAVE LEAGUE supplies it at cost, the price, including the mailing, being 35 cents. A solid gold button is furnished for \$2.00 prepaid. Address all communications to SHORT WAVE LEAGUE, 99-101 Hudson St., New York.

## BARTER and EXCHANGE FREE ADS (continued)

HAVE FIVE TUBE THREE BAND broadcast receiver. Atwater Kent Model 145. Swap for Ham receiver. Also have complete Lawton Extension University course. Higher accuracy. What Ham equipment have you? J. H. Mason, W8QKV, 1110 Ovid Street, Elmira, N. Y.

WANTED. MILLER PRESELECTION, no tubes required, in exchange for Walker Turner "500" Series Jig Saw no motor, many accessories, good condition or what have you? William Yates, 33 Weaver Ave., Bloomfield, N. J.

WILL TRADE CANDLEY SYSTEM code and typing courses. Will sell or trade: 25 watt Utah Xmitter, Barr Transceiver (DB3), and other apparatus. Want Phone Xmitter—or? W9QKS, 819 Wyandotte, Kansas City, Mo.

HAVE 1,000 DIFFERENT STAMPS from more than 60 countries, several unused model airplane construction kits. Will swap for simple 1 tube transmitter, radio parts, or what have you. George Sangrik, 2498 West 7th Street, Cleveland, Ohio.

WILL SELL OR SWAP MAJESTIC B Eliminator also A Eliminator for what have you. Also will sell (not swap) an Instructograph with three tapes and oscillator. W. Burkhardt, 242 Ridge St., Honesdale, Pa.

ONE REWOUND DODGE GENERATOR 110 volts A.C. 60 cycles at 1800 r.p.m. A. C. Watts 500 self excited. Will sell or trade. What am I offering? R. C. Gardner, 2689 L St., San Diego, Calif.

SJROMBERG CARLSON AUTO set. Six tube not including rectifier. Steering wheel control. Large speaker. Make cash offer. George Swanson, Box 224, Englewood, N. J.

SELL, SWAP AIR-MAIL COVERS. Have many magazines for stamp collectors and other hobbyists. Let me know your wants and what you have. Swap lists. Will answer all inquiries. Felgenbaum, 42 Jefferson, Yonkers, New York.

HAVE ALL KINDS OF RADIO parts, too numerous to mention. Would sell or trade for photography equipment, chemicals, stamps. Call or write A. Seidman, c/o Sieser, 54 Willett St., N. Y. C.

AM IN THE MARKET FOR AN instrument for testing gold, silver, other minerals and metals, buried treasure, etc. Address John Chewing, General Delivery, Wichita, Kans.

WILL SWAP ONE OR MORE new 1937 Philco All-wave aerial kits for good high-impedance phono-pickup. Roy Barry, St. Marys, W. Va.

WILL TRADE KEYSTONE 16MM. Model D59 motion picture projector, rheostat controlled, excellent condition, also Kantam Kodak Vest Pocket folding camera for miniature or candid camera. Write Bernard Koszeth, 2639 Morris Avenue, Bronx, New York City.

FOR SALE: DOERLE TWO TUBE allwave receiver. Verified reception from Russia, England, Italy, So. America, Portugal, Germany, Czechoslovakia, Switzerland, Guatemala and many others. Enclosed in metal case. Price \$9.50. Richard Briggs, 848 Belmont St., Watertown, Mass.

HAVE TENOR BANJO, A ROKING course by DeForrest Selley-Text kit of the "Moth" brand new. What am I offering? Lewis Molteni, 519-21 St., Union City, New Jersey.

BEST OFFER ACCEPTED FOR New Doerle 38, factory wired Duo Gain Condenser 8 Class Tubes. Factory price \$34.50. Set has not been used. Details gladly given. D. Wade, Box 303, Duluth, Minn.

WILL TRADE OR SELL RADIO parts of all kinds. Send your offer. Radio cabinets of all sizes. Elster T. Huffman, News Stand, Pikeville, Kentucky.

TRADE RCA NO. 104 SPK's, golf clubs and bag "2 drivers, 6 irons," acetylene welding equip. etc. Want 5-6 tube A.C.S.W. receiver. Port. Typewriter, radio parts, tubes, etc. F. P. Melin, 7050 East End Ave., Chicago, Ill.

HAVE CARTER GENEMOTOR 250 V 50 ma., 1-6 volt dynamic speaker 8" with case for mounting in auto, trade for factory made S W receiver of good make. Wm. E. Fuller, 709 Ferndale Ave., Lansing, Mich.

I WILL DO PICTURE FINISHING on any size roll of film 35 M.M. up for radio parts or what have you? Walter Kepner, Jr., R. 11, Box 299C, Indianapolis, Ind.

SELL OR SWAP: W.E. French telephone, New Acme phones 2800 ohms, Redifone A.C. Mts. (0-250) Meter, Radio Operating Q. & A. Want good preselector or Antenna Tuner. Make offers. A. Nutkins, 1439-52nd St., Brooklyn, N. Y.

SELL OR TRADE—MEISSNER 8 tube super complete and in perfect condition for \$25.00, or will swap for low power 10 meter tube. Chester Dryden, 6614 W. 34th St., Berwyn, Ill. W9ZST.

WILL TRADE GENERAL ELECTRIC phonograph motor, Kolster magnetic pickup and dynamic speaker (3 inch) for amateur receiver or other short wave equipment. All letters answered. Gene Gray, 440 Floral Ave., Ithaca, N. Y.

ALL WAVE SETS COMPLETE—8 tube super, 6 tube T.R.F., 2 tube A.C.-D.C. Also 5 tube battery portable. Want movie equipment, films, cash, etc. L. B. McCullough, 20 Rowland Ave., Mansfield, Ohio.

HAVE WALKER TURNER DRIVER bench saw and Lathe and Bandsaw and microscope. All are less than one year old and very slightly used. Want good Hallicrafters receiver. Billy Richardson, Rich's Cafe, Halstead, Kans.

BEST CASH OFFER TAKES COMPLETE National SW-43, revr. 10 coils, 13 to 209 meters, spkr. and Power supply. Very good condition. What am I offering? Wm. C. Palmer, 7240 Ridge Rd., Parma, Ohio.

FOR SALE—A BIAS COINSET. In good condition, but is dusty. Will sell for \$12.75. Also will swap one new Philmore crystal set (Super) for what have you. Address—Terrence Gines, 7020 Lawrence, S. C.

FOR SALE—3 TUBE AC RECEIVER, 600 watts with tubes, dynamic speaker, coils, etc. Mounted in wood cabinet with crackle finish panel. Write for picture and further information. Ralph Michelson, 2360 Stair Ave., Detroit, Mich.

FOR SALE—BRIGGS STRATON six volt charger, Zenith wind charger. Five tube 13 less radio. Maxing gasoline motor, RCA amplifier and speaker, Tenor Saxophone. Write for lowest price. Gottfried Streckert, Chilton, Wis.

HAVE A COMPLETE COURSE ON radio from National Radio Institute for what have you, would prefer short wave radio, course cost \$150.00 year 1934. W. J. Sharman, 304 E. 126 St., N. Y. C.

SELL OR TRADE MOSSBERG NO. 6 scope Sight, new Two Hammarlund SWK-6, one SWK-4, L.C.A. One 4, one 6 prong coil kits, wanted DC SWK. C. Brown, 333 Hazel, Lancaster, Pa.

WISH TO SELL READRITE Analyzer Model 710-A. Used very little. Five tube 13 less type tube. Must sell for \$14.00 because of condition. Will trade for what have you. Louis T. Elkamp, Box 307, Cochrane, Wis.

FOR SALE OR TRADE—RACO DX-4 short wave receiver; also miscellaneous short wave equipment, in first class condition. Write for details. Send your offers to Wm. Custick, 431 Locust, Ottawa, Kans.

JAMAICA CALLING! POSTCARD Collectors—send Picture Postcard from your locale and receive attractive postcard from here. Prompt reply. Cards from America require three cents postage. Eric Allan Sampson, P. O. Box 204, Kingston, Jamaica, British West Indies.

SELL: TRANCEIVER USING 76-41 tubes, 5 meters. Transceiver using 6AG-6AG-6AG-76-41 with power supply. Want to buy receiver with extra 1-160 meters. Make offer. Calvin Moreland, 1011 Willowbrook Ave., Compton, Calif.

WANTED: AN R.M.E. 69 IN slightly used but perfect working condition. M. Stabin, 5501-14th Ave., Brooklyn, N. Y.

WANT COMMUNICATIONS RECEIVER and transmitter and receiver parts. Have complete 3x8 printing outfit, collection of 2500 different glass coils will buy for cash. Send complete description, value. E. Steffen, Co., 793 CCC, Hill City, S. Dak.

JENKINS TELEVISOR AND RECEIVER 60 line lens disc and Synchronous Motor. Sell, Trade for 16 mm. movie equipment, as Projector Movie Camera, films. If interested will send photograph, details. David Gross, 2145 Ocean Ave., Brooklyn, N. Y.

FOR SALE OR SWAP: A 22 CALL Remington Long and Short Rifle, good condition. Will trade for new or good used servicing or shortwave equipment. Make offer. Rayfield J. Reilhan, 64 Pine St., Rutland, Vermont.

WILL TRADE CHEMICAL LABORATORY, not a set, including all apparatus, slightly used but in good condition. Worth about \$60. (For complete transmitter or receiver in good condition. D. M. Sheehan, 66 Franklin Street, Stincham, Massachusetts.)

FOR SALE—SCOTT ALL-WAVE XV complete with 1938 Warrington Console \$135.00. Guarantee has 4 1/2 years to run. Factory seals are intact. Selling because I need money. Jesse Schein, 5 So. Carey St., Baltimore, Md.

WANTED: RIDER MANUALS and other technical radio books. Please state condition, cash price, or what you want. Chester Dryden, 309 W. Fourth Street, Frankfort, Ky.

SELL, ULTRA STRATOSPHERE 10 tube transmitter with tubes, coils 2 1/2-15 meters. 5 meter transmissions over fifty miles with QSL, 415 meter, Ten meter reception. K3s, H15, VK1, 2, 3, \$27.00. Frank Lantern, 91 Baker Street, Berea, Ohio.

SWAP—14 TUBE SUPERHET FOR Harley Davidson motorcycle. Radio built around RCA brain. Consists of crystal phasing, standby switch, 11 meter, volt meter, band-changing switch, beat oscillator. John Elio, 2877 E. Squire Ave., Cudahy, Wis.

WILL SWAP WESTERN ELECTRIC photo-electric cell, or \$5.00 Gilbert Electric Eye set with 2 relays for fairly good Ham-band Xtal, or a used transmitting tube. Kenneth Beck, Jr., 445 Kennedy Ave., Pittsburgh, Penna.

I HAVE HAM EQUIPMENT consisting of tube, cond., cabinets, chokes, coils, etc. for sale or trade. All letters answered. Carl Guest, East Fultonham, Ohio.

WESTINGHOUSE WR306 9 metal 1 glass tubes, 120 to 18500 K.C. 10 watt output, excellent \$25.00. Sell or trade for "ham" receiver with R.F.O. Peter Kirkouskas, 419 N. Delaware, Erie, Pa.

WILL TRADE GOOD GRADE short wave parts for a good tennis racket and a small camera. Write giving description. Will send swap list. John J. Vilkas, 1515 South 49th Court, Cicero, Illinois.

HAVE 10" MANNHEIM SLIDE rule graduated as closely as 20", also magnifier to fit. Rule has had slight use. I can use books of instruction on radio. James Tucker, Third St., Box 302, Chelmsford, Mass.

HAVE OIL PAINTINGS, SIGN Painters letter patterns, radio parts, diagrams for one and two tube sets some real old timers. Want radio parts. John Havens, Doe Run, Missouri.

WANTED TO BUY OR SWAP. A good 2 tube R.F. Preselector in good condition. With coils but without tubes and power supply. Will answer every letter. David Bulkley, 85 Griffen Ave., New Rochelle, N. Y.

SHORT WAVE LISTENERS: Let's get acquainted with SWL's in foreign countries. We QSL here 100%. C'mon OMS XYLs and YLs. QRA OM Chiff 73, Honolulu, Hawaii. QRA OM Chiff 73, Honolulu, Hawaii.

SELL SPRAGUE 500 volt, 500 mill DC generator, \$13.50; 32 volt DC 115 watt soldering iron \$1.75; 2-32 volt DC 1/4 hp motors \$3.50; 32 volt DC generator, 180 volt, tapped, filtered, bypassed, \$7.00. Willard Kersey, Oregonia, Ohio.

WOULD BE INTERESTED IN corresponding with persons not living in North or South America. Interested in swapping recent issues, unused stamps, coins, etc. So what say? Herman Harjes, 3rd., 41-13—74th Street, Jackson Heights, N. Y.

SWAP NEW FIRST NATIONAL Television Correspondence Course (67 lessons) for what have you in ham equipment. Real opportunity for someone who wants to learn radio. C. L. Key, Jr., 110 W. Mathews St., San Marcos, Texas.

WANTED OLD MODEL SKYRIDER Sky rider, glass tubes, built in splkr., working order, cheap for cash. Prefer Crystal Filter. Hear from persons east of Mississippi River. W. S. Crooks, W8LVG, Box 15, Stow, Ohio.

I HAVE LOTS OF RADIO PARTS I would sell or trade for test equipment such as volt ohm meter, all wave oscillator. Abe Oehstein, 1802 High St., Fort Wayne, Ind.

INSTRUCTOGRAPH CODE Machine with 5 rolls tape, instruction book, sending key. Will sell for cash or exchange for good all wave test oscillator, or what have you. Milton Lippin, 214 E. 54 St., Brooklyn, N. Y.

HAVE—TRANSIT, REQUIRING slight repair, without tripod. Offered 100% \$15.00 will put same in A-1 shape and buy tripod. Want good receiver, x.mtr. parts or cash offer. E. C. Hahn, 93 Wex Ave., Buffalo, N. Y.

SELL OR SWAP VOL 2-3-4-5 Rider Manuals for 16mm Movie Projector or Hallicrafters Sky-Buddy. Also GE Elect Turntable Silver Marshall 9-tube Super-Het., 8-tube SM TRF Set, Atwater-Kent 7-tube TRP chassis. Schalla, 1553 Ballard St., Lansing, Mich.

TRADE OR SELL 4 TUBE AND one tube short wave receivers in good condition. SWLs, send me your SWL card and I'll send you mine. Louis Oberdoster, 402 Ridge Ave., Allentown, Pa.

SELL SWAP, TELESCOPE E. Vion Paris, Power 40 times, Double Achromatic cost \$29.50 new, 2 1/2". Carl Zeiss field glasses power 8 times cost new \$15. Good condition. Want Volt-Ohm-Milliammeter, signal generator. Conant, 91 Crest Ave., Chelsea, Mass.

Please mention SHORT WAVE & TELEVISION when writing advertisers

**OWN A ROYAL  
PORTABLE ON  
YOUR OWN  
TERMS**

**FREE  
HOME  
TRIAL**



**ONLY  
A FEW  
CENTS A  
DAY**

**ACT NOW!**  
You needn't risk a penny!

Royal's generous free HOME TRIAL will prove to your satisfaction that a genuine, latest model, factory-new Royal Portable is the typewriter for you . . . simple to use, convenient, built for a lifetime of service! Includes such office typewriter features as full-size keyboard, Royal's famous Touch Control, Finger Comfort Keys, and many others. Terms to suit your purse—cash or only a few cents a day. Mail the coupon today for full information. No obligation.

**ACT NOW! TODAY!**

MAIL

ROYAL TYPEWRITER CO., INC.  
Dept. B-921, 2 Park Avenue,  
New York, N. Y.

Tell me how I can own—for only a few cents a day—a latest model Royal Portable—with Carrying Case and Instant Typing Chart FREE.

Name .....

Street .....

City .....

I already own a ..... Typewriter,  
Serial No. .... Tell me how much  
you will allow on it as CASH payment on a  
New Royal.

**RADIO**

holds great rewards  
for trained men



The big opportunities in Radio will be enjoyed by trained men. The International Correspondence Schools Radio Course, prepared by leading authorities and constantly revised, will help make you a trained man! A fascinating book—FREE.

**AVIATION ENGINEERS**  
are leaders in modern progress



Aviation depends upon engines, and knowledge of aviation engines is a long step toward success in this rapidly growing industry. Many leading aviation engineers today took their first step by mailing a coupon to the I. C. S. at Scranton. Why don't you follow their example?

**INTERNATIONAL CORRESPONDENCE SCHOOLS**

Box 2878-E, Scranton, Penna.

Explain fully about your course in the subject marked X:

RADIO  AVIATION

Chemistry  Accountancy  
 Invention  Advertising  
 Refrigeration  Electrical Engineering  
 Air Conditioning  Drafting  
 Architecture  Show Card Lettering  
 Good English

Name.....Age.....

Address.....

**First U.S. Television Station  
on Wheels**

(Continued from page 600)

"Our immediate purpose is to train a group of men in handling the problems of special events. We shall have need of all the practical experience we can accumulate between now and the day when television becomes a daily public service."

The new mobile television station, recently delivered to the National Broadcasting Company at New York, consists of two specially constructed motor vans, each about the size of a large bus.

Apparatus for picture and sound pick-up is installed in one, and a video (picture) transmitter, operating on a frequency of 177,000 kilocycles (1.69 meters) in the other. In the metropolitan area, where many tall buildings make high-frequency transmission difficult, the unit's workable range is about 25 miles. Ten engineers are required to operate the two television units. In the experimental field work NBC's present mobile sound transmitter will be included in the station.

Both picture and sound is relayed by micro-wave to the television transmitter in the Empire State Building. There the programs will be broadcast to the 100 television receivers which have been placed in the homes of trained observers throughout the metropolitan area. The television system used is entirely electronic, based on the cathode ray tube.

The van mounting the video, or picture, apparatus is the mobile equivalent of a television studio control room. It is fitted with television and broadcast equipment similar to that now in use at Radio City. This includes two cameras, video amplifiers, blanking and deflector amplifiers, synchronizing generators and rectifiers for supplying the Iconoscope beam voltages. The principal sound apparatus consists of microphones, microphone amplifiers and sound mixing panels. All the equipment is mounted on racks extending down the center of the van, affording easy access to any part for repairs and the alterations which will arise from the outdoor experimentation.

Directly in front of the operating engineers in the semi-darkened control room are two monitoring kinescopes. One shows the scene actually being transmitted; the other the scene picked up by the second iconoscope camera preparatory to transmission.

Sound is picked up by a variety of microphones, including the parabolic microphone, and is monitored by loud-speaker. An elaborate telephone *cnc* circuit will keep the ten engineers in contact with each other.

The two Iconoscope cameras, mounted on tripods, are technically equivalent to studio cameras, although considerably lighter in weight. Focusing is accomplished by looking directly onto the plate of the Iconoscope, instead of through a separate set of lenses, as in the case of studio cameras. The cameras transmit the image through several hundred feet of multiple core cable, affording a considerable radius of operations. In addition four operating positions are available on the roof of the van.

The micro-wave television transmitter is housed in the second van, linked to the first by 500 feet of coaxial cable. Here the principal apparatus is the radio frequency unit, generating the carrier wave for picture signals, and modulating apparatus for imposing picture signals on this carrier. The signals are transmitted to the Empire State station's directional receiving antenna either from a single dipole antenna raised on the van's roof, or from a highly directive antenna array.

**Index to Advertisers**

<b>A</b>	
Ace Radio .....	649
Allied Engineering Institute .....	640
Allied Radio Corporation .....	637
Amperite Co. ....	640
Astatic Microphone Laboratory, Inc. ....	649
<b>B</b>	
Barter & Exchange Free Ads. ....	654, 655
Bliley Electric Co. ....	636
Brush Development Co., The. ....	684
Bud Radio, Inc. ....	634
Burstein-Applebee Co. ....	638
<b>C</b>	
Cameradio Co. ....	640
Candler System Co. ....	643
Cannon, C. F., Co. ....	636
Classified Advertisements .....	654
Clough-Brengle Co., The. ....	640, 653
Cornell-Dubilier Corp. ....	645
Coyne Electrical School. ....	698, 639
<b>D</b>	
Dataprint Company. ....	638, 653
Dodge's Institute. ....	643
<b>G</b>	
Goldentone Radio Co. ....	653
Gold Shield Products. ....	638, 651
<b>H</b>	
Hallcrafters, Inc., The. ....	Back Cover
Hammarlund Manufacturing Co., Inc. ....	645
Hudson Specialty Company. ....	641
<b>I</b>	
Instructograph Company. ....	643
International Correspondence Schools. ....	656
<b>K</b>	
Kelsey Co., The. ....	643
Korrol Radio Products Co. ....	638
Kusterman, Oscar B. ....	632
<b>L</b>	
Lejay Mfg. Co. ....	651
<b>M</b>	
Midland Television, Inc. ....	643
Modell's. ....	644
Montgomery Ward & Co. ....	641
<b>N</b>	
National Company, Inc. ....	Inside Back Cover
National Plans Institute. ....	653
National Radio Institute. ....	593
National Schools. ....	643
New York Y.M.C.A. Schools. ....	643
<b>P</b>	
Par-Metal Products Corporation. ....	634
<b>R</b>	
Radio Amateur Course. ....	Inside Front Cover
Radio & Technical Publ. Co. ....	642
Radio Constructors Laboratories. ....	633
Radio-Craft. ....	646
Radio Publications. ....	641, 644, 650
Radio Training Assn. of America. ....	643
Raytheon Production Corporation. ....	635
RCA Institutes, Inc. ....	643
RCA Manufacturing Co., Inc. ....	651
Royal Typewriter Company, Inc. ....	656
<b>S</b>	
Sannick. ....	653
Scott, E. H., Radio Laboratories, Inc. ....	647
Short Wave Coil Data Book. ....	650
Short Wave League. ....	648
Sky Pilot Organization, The. ....	634
Solar Mfg. Corp. ....	636
Sprayberry Academy of Radio. ....	643
Standard Transformer Corporation. ....	638
Superior Instruments Company. ....	634
Supreme Radio Supply Co. ....	653
<b>T</b>	
Technifax. ....	640
Telex Co. ....	642
Triplett Electrical Instrument Co. ....	653
Try-Mo Radio Co., Inc. ....	651
<b>U</b>	
Ultra High Frequency Products Co. ....	631
Ultra Precision Instruments Co., Inc. ....	636
United Radio Co. ....	638
United Transformer Corp. ....	647
<b>W</b>	
Wellworth Trading Company. ....	638, 640
Wholesale Radio Service Co., Inc. ....	649

(While every precaution is taken to insure accuracy, we cannot guarantee against the possibility of an occasional change or omission in the preparation of this index.)

Please mention SHORT WAVE & TELEVISION when writing advertisers



In these few short months the NC-80X has become part of the National tradition. Their advanced circuit details, including the wide-range crystal filter and high IF frequency for image rejection, have brought a new standard of performance to the low priced field. Their thorbred construction keeps that performance consistently high. And their convenience makes operation swift, accurate, and tireless.

# NATIONAL NC-80X

NATIONAL COMPANY, INC.  
Malden, Mass.

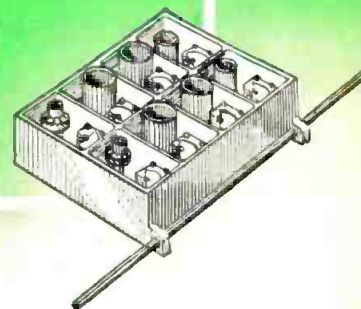

*Announcing  
the*

# SKY CHALLENGER II

*With the New-Hallicrafters Infinite Image Rejector\**

We are proud to announce the Sky Challenger II, not as just another new receiver, but as a definite contribution to amateur radio. With the Sky Challenger II, we offer another new and far-reaching Hallicrafters development—the Infinite Image Rejector.

With this new circuit, equivalent in operation to several expensive pre-selectors, and an integral part of the New Sky Challenger II, annoying image interference is completely eliminated. But this is not all. It has the same famous 1000° Spiral Band Spread System used in the Super Skyrider, and a host of other quality features that make it an outstanding value at its new low price. See it! Operate it! Compare it! Write for full information today.



- ★ 9 Tubes
- ★ Infinite Image Rejector
- ★ 1000° Spiral Band Spread
- ★ New Recessed Main Tuning Dial
- ★ Full Coverage 38 MC to 540 KC (7.9 to 545 meters)
- ★ Beat Frequency Oscillator
- ★ Tone Control
- ★ "S" Meter Terminals
- ★ Crystal Filter Circuit
- ★ Iron Core I.F.'s
- ★ AVC Switch
- ★ Better Sensitivity and Selectivity

**the hallicrafters inc.** 2601 Indiana Ave., Chicago, U. S. A. • Cable Address: "HALLCRAFT," Chicago

**"WORLD'S LARGEST BUILDERS OF AMATEUR COMMUNICATIONS RECEIVERS"**

\* Patent Applied For